

# The Wireless World

THE PRACTICAL RADIO JOURNAL  
with Complete Foreign Programmes

4<sup>D</sup>

Friday, November 24th, 1933.

## BURTON CLASS "B" CONVERSION UNIT

This unit is intended to be added to existing battery sets in order that moving coil reproduction may be obtained. It contains a specially designed driver and output transformer, and the whole unit is housed in a highly polished brown bakelite case. The unit takes an average current of 6 m.a. and is capable of delivering 2 watts output without distortion.



Made by C. F. & H. BURTON, Progress Works, WALSALL.

35/-

## TELSEN IRON-CORED COILS

—the smallest and most efficient in the world

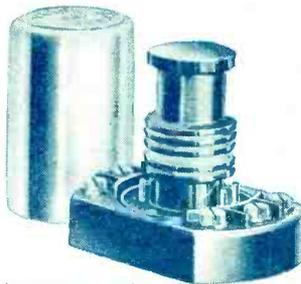

Employing an iron-dust core, these coils are the result of extensive research. They do not incorporate switching since this is not only much less efficient than a well designed external switch but also restricts the symmetrical arrangement of controls. They consequently take the fullest advantage of all the benefits that the "Iron Cored" principle provides.

TWIN MATCHED - 17/-  
TRIPLE MATCHED - 25/6

Announcement of the Telsen Electric Co. Ltd., Aston, Birmingham

TELSEN FOR EVERYTHING IN RADIO

## EVERY TEST

D.C. AND A.C. AMPS VOLTS OHMS

WITH ONE COMPLETE INSTRUMENT



The Avometer is the only complete testing instrument which gives direct readings in amps, volts and ohms without the necessity for mathematical calculations. It is indispensable to the Service men of leading radio manufacturers as the only instrument that adequately meets their needs.

Two models, one for D.C. only, 8 GNS. and the Universal Avometer giving both D.C. and A.C. readings (50 cycles) 12 GNS. Deferred Terms if desired.

Illustrated Pamphlet post free.

## The AVOMETER

BRITISH MADE

AUTOMATIC COIL WINDER & ELECTRICAL EQUIPMENT CO., LTD., Winder House, Douglas Street, London, S.W.1  
Telephone: Victoria 3405-7.

## COLVERN FERROCART COILS

COMPACT!  
EFFICIENT!  
SELECTIVE!

We have written a booklet explaining the advantages of Ferrocart coils. May we send you a copy? It's free!

COLVERN LIMITED, ROMFORD, ESSEX.

London Wholesale Depot: 150, King's Cross Road, W.C.1.

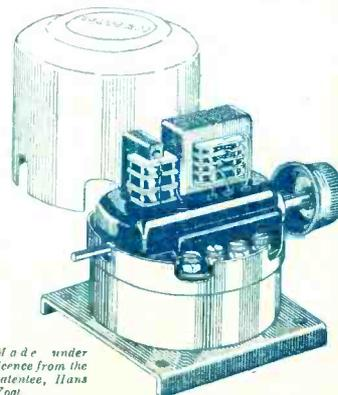

Made under licence from the patentee, Hans Vogt.



**Quality and power  
consistently maintained  
throughout long life**

**120 volt  
144,000 milliwatt hours  
GUARANTEED**

PRICES:

60v : 5/6. 99v : 9/-  
108v : 10/- 120v :  
11/- 150v : 14/-  
60v Triple Capa-  
city : 12/-



ASK FOR  
**G.E.C. H.T.**  
TO-DAY

Sold by all Wireless Dealers  
MADE IN ENGLAND

**A TRIAL MEANS YOU'LL ALWAYS USE G.E.C. H.T.**

*Advt. of The General Electric Co. Ltd., Head Office and Public Showrooms : Magnet House, Kingsway, London, W.C.2.*

*Mention of "The Wireless World," when writing to advertisers, will ensure prompt attention.*

*Definite Data*

# BULGIN H.F. CHOKES

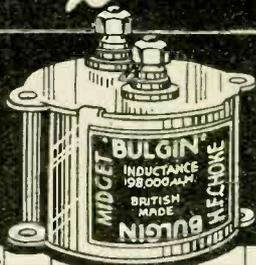

**BULGIN MIDGET CHOKE**  
List No. H.F.8.  
Price 2/3 each.

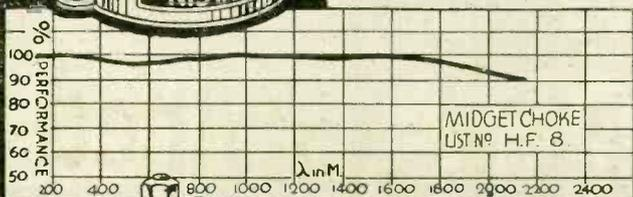

**BULGIN STANDARD CHOKE**  
List No. H.F.9.  
Price 3/6 each.

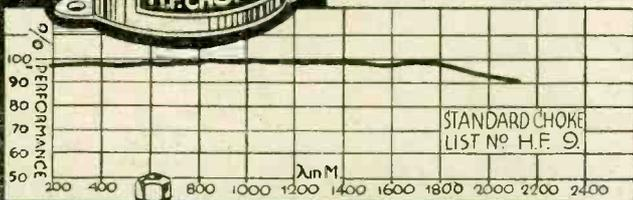

**BULGIN SUPER-HET H.F. CHOKE**  
List No. H.F.10.  
Price 5/6 each.

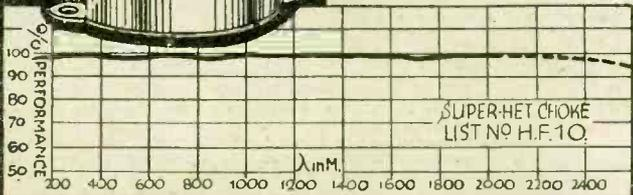

REGISTERED DESIGN No. 773899.

USE tested components for the best results in any apparatus. The technical data shown here speaks louder than words to the discriminating constructor and counts for the phenomenal large sales of these components since their introduction. BULGIN Metal Cased H.F. Chokes are *totally screened*, can be mounted through chassis or on baseboard. Fitted with shake-proof terminals and handsomely finished in frosted aluminium.

### SCREENED MIDGET H.F. CHOKE.

A REMARKABLE choke at a remarkably low price. Small, neat in appearance, it can be incorporated in the smallest of receivers. Although the price is so reasonable the inductance is approximately 198,000 μH., and in operation the choke gives a smooth choking effect from 200 to 1,750 metres. The self-capacity is only 3.5 μμF., and the D.C. resistance is approximately 380 ohms. Fitted in our new registered design universal type screening case for all positions of mounting.

### SCREENED STANDARD H.F. CHOKE.

ANOTHER popular type of screened H.F. choke with a self-inductance of approximately 250,000 μH. It is a splendid general purpose component for use with modern high efficiency valves. Covers a wide waveband from 200 to 1,800 metres without peaks or blind spots. Fitted in our new registered design screening case for universal mounting, and has the low self-capacity figure of only 2.5 μμF. D.C. resistance 400 ohms approx.

### SCREENED SUPER H.F. CHOKE.

THIS high frequency choke has the amazing inductance of 500,000 μH. making it suitable for use in all super-heterodyne receivers and positions where a choke of super-efficiency is required. It has only been made possible by extensive experience in the design and manufacture of H.F. Chokes and after long and extensive laboratory research. Its "curve" is a straight line from 180 to 2,500 metres, a performance unparalleled, and its self-capacity is exceedingly low, 1.5 μμF. approx. Fitted in our new registered design universal type screening case, for universal chassis, baseboard, or sub-chassis mounting. D.C. resistance approx. 500 ohms.

The curves shown have been prepared for us by a well-known independent technical consultant.  
SEND FOR LATEST 80-PAGE CATALOGUE No. 153 "W."  
Enclose 2d. postage.

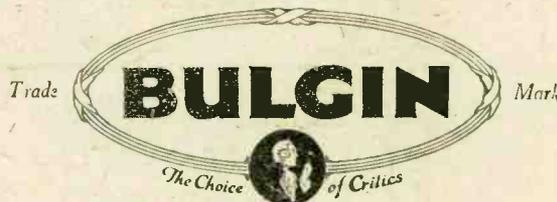

**A. F. BULGIN & CO. LTD.**

ABBEY ROAD, BARKING, ESSEX  
TELEPHONES GRANGEWOOD 3266 & 3267

SHOWROOMS: 9, 10, 11, CURSITOR STREET.

CHANCERY LANE. E.C.4

Telephone: Holborn 2072

# Cheaper because they are better

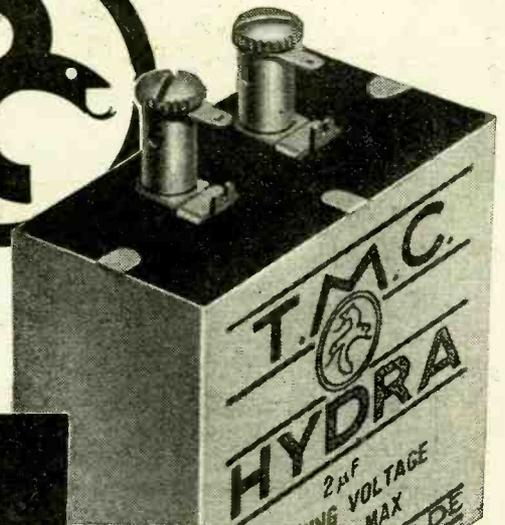
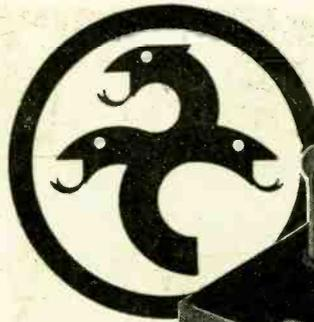

**H**YDRA design plus the newest manufacturing methods—that is the secret of the success of the new British Hydra condensers. Because they are made more accurately, more surely, and more speedily in the T.M.C. London factory—for that very reason—they are cheaper to buy. British Hydras then, for your new set. Your dealer sells them.

**T.M.C.**  
**HYDRA**  
*the better British  
Condensers*

**Low Prices.** Tinned soldering tags or screw terminals for same price. Guaranteed for 12 months.

Send to-day for price list to :

SOLE SALES DISTRIBUTORS FOR GREAT BRITAIN

**HARWELL LTD**

The Sessions House,  
Clerkenwell Green, London, E.C.1  
Telephone: Clerkenwell 6905

Export enquiries to:  
**TELEPHONE MANUFACTURING Co. Ltd.,**  
Suppliers of condensers to British Post Office,  
Hollingsworth Works, Dulwich, London, S.E.21.  
Cables: "Bubastis, London."

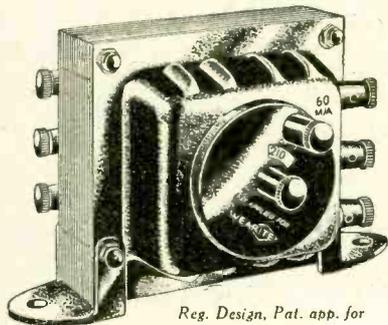

Reg. Design. Pat. app. for

**The T21A**

To give 250v.-0-250v. at 60 milliamps, 2v.-0-2v. at 1 amp. and 2v.-0-2v. at 4 amps. Complete with exclusive foolproof voltage selector.

PRICE **25/-**

**MAINS TRANSFORMERS**

Built in types covering every input and output voltage and with a big selection of tapping points, the Wearite range covers every possible need.

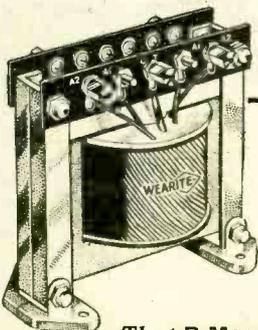

The 'B Mag'

Output Choke  
Type **11/-**

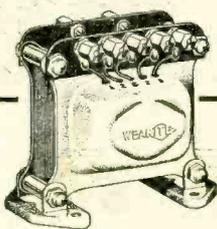

Type B.J.  
**8/6**

The 'B Mag' Driver Transformer

**CLASS 'B' COMPONENTS**

These two 'B Mag' Components provide a perfect pair matched to each other, and so arranged with special tappings to match any driver or 'B' valve and any loudspeaker... a perfect team.

## for EFFICIENCY

with MAINS and BATTERY  
insist on

Regd. Trade Mark

**WEARITE**  
**COMPONENTS**

WHATEVER power your customers use for their radio—A.C., D.C., or Battery—show them the way to efficient working—sell them Wearite Components.

Wearite Mains equipment has long been the choice of discriminating set manufacturers and designers. With the introduction of Class 'B' Wearite again took the lead. Whatever your customers' needs—if it's components—sell them Wearite.

WHY NOT BUILD THE WEARITE TEAMSTER ?

Send this coupon to-day.

**COUPON** To Messrs. Wright & Weaire, Ltd.,  
740, High Road, Tottenham, London, N.17.

Please send me copy of full size blue print and constructional details showing how to build the WEARITE TEAMSTER. Also your booklet S.32 together with literature on "Class B."

NAME .....

ADDRESS .....

W.W. 24/11/33 .....

Please write in block letters.

Mention of "The Wireless World," when writing to advertisers, will ensure prompt attention.



# CATHODE RAY OSCILLOGRAPHS

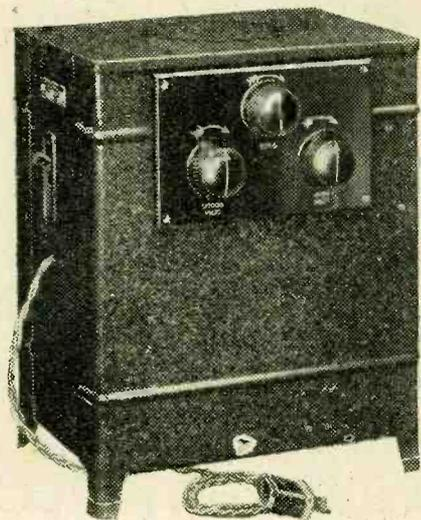

Exciter Unit. Prices on application.

# OSCILLOGRAPHS

with the improved  
Fluorescent Screen

for

# TELEVISION AND RADIO RESEARCH

The Ediswan Cathode Ray Oscillograph is of the "sealed off" type and possesses a number of unique refinements. Full particulars of this tube and of suitable circuits for its use as a Television viewer, or in research work, will be supplied on request.

*We invite enquiries for:—*

- ★ Mercury Vapour Rectifiers.
- ★ Grid controlled discharge tubes for time bases,
- ★ High Vacuum Diodes.
- ★ Transmitting Valves, low and medium powers.

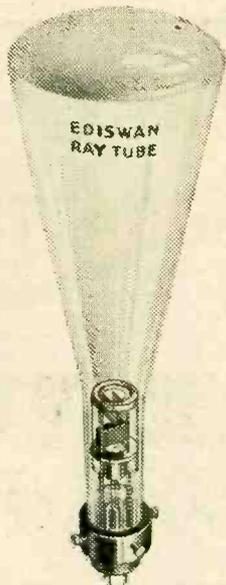

Ediswan Ray Tube  
Price £6. 6. 0.

# EDISWAN

# RADIO VALVES



THE EDISON SWAN ELECTRIC CO.  
LTD., 155, CHARING CROSS ROAD,  
W.C.2

*Used by all Government Departments*



Send for the NEW Polar Catalogue

# POLAR

## "STAR MINOR" FOUR GANG CONDENSER WITH SEMI-CIRCULAR DRIVE

### SPECIFIED

FOR THE

## A.V.C. STRAIGHT

## FOUR

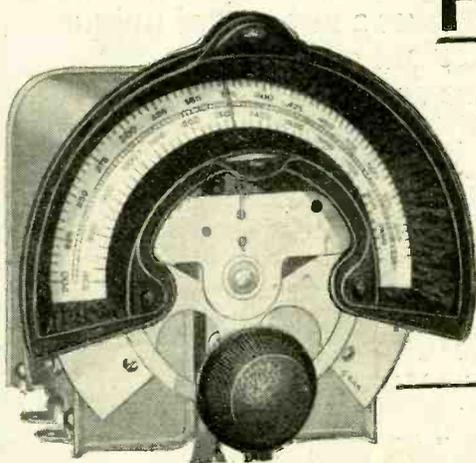

Cadmium plated steel frame mounted on Flexible baseplate, Trimmers operated from top. The sections are matched to within  $\frac{1}{2}\%$  or 1 mmfd. (whichever is the greater).

4 x .0005  
Condenser only  
25/-

Complete as shown.  
**30/9**

**WINGROVE & ROGERS LTD.**

188/189, STRAND, LONDON, W.C.2

Works : Old Swan, Liverpool.

'Phone : Temple Bar 2244

3995

# STILL THE SAME BATTERY!

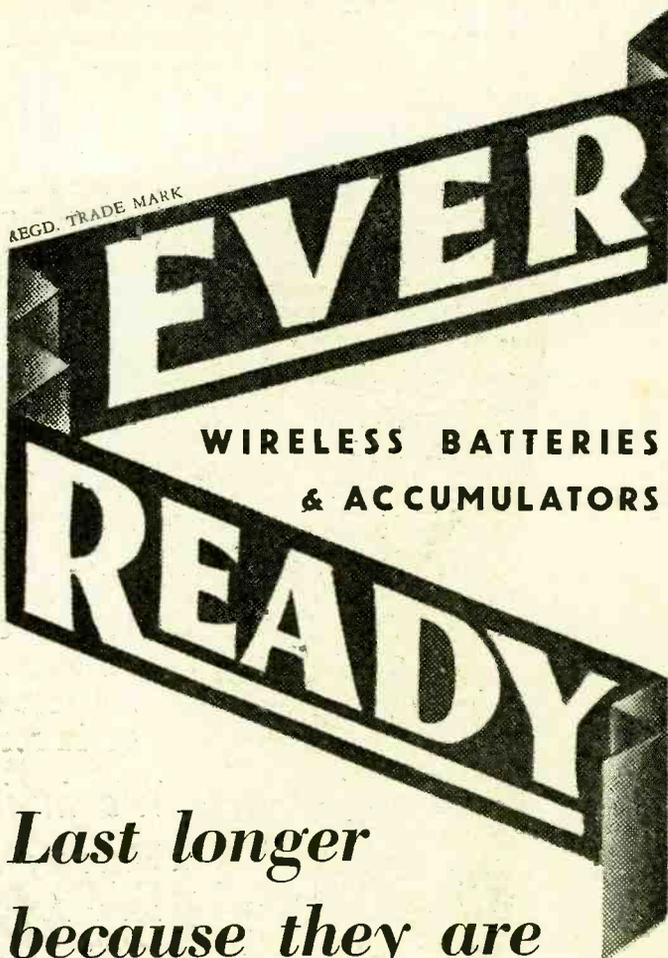

*Last longer  
because they are  
made to fit your set  
precisely*

**HERE'S A HINT FOR PYE TWIN TRIPLE OWNERS**

Fit these Ever Ready Batteries: H.T. Port. 19, G.B.4, L.T. 2383—all made specially for it. Or simply ask your dealer for the Ever Ready List, showing all popular makes with their special Ever Ready batteries. Your set will be powered perfectly by its appropriate Ever Ready batteries.

THE EVER READY COMPANY (GT. BRITAIN) LTD.,  
HERCULES PLACE, HOLLOWAY, LONDON, N.7.

# Modern design... plus unrivalled quality and unequalled performance

The new Dubilier Type 9200 Paper Condenser is a most revolutionary change in Condenser design. It embodies all the features essential to the Constructor and follows the modern 'all-metal' trend of design. *Here are its outstanding features which offer conclusive proof of its supremacy.*

1. True non-inductive type of construction.
2. Available in various grades for working voltages from 300-900 D.C. peak.
3. Adequate factor of safety for each.
4. New method of fixing to chassis.
5. Aluminium containers with moulded bakelite top of distinctive appearance to match other components.
6. Takes up minimum amount of space on chassis.



Look for the familiar blue and red carton in your dealer's shop.

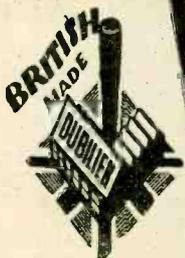

# DUBILIER

## PAPER CONDENSERS

Type 9200—Test volts 650 D.C. Wkg. volts 250 D.C.  
1 mfd. 2/6    2 mfd. 3/6    4 mfd. 7/-

DUBILIER CONDENSER CO. (1925) LTD., DUCON WORKS, VICTORIA ROAD, N. ACTON, LONDON, W.3

*Advertisements for "The Wireless World" are only accepted from firms we believe to be thoroughly reliable.*

# 'Ferrocart'—a triumph of precision



COLVERN SPECIALISE IN COILS

- Ferrocart coils are the outcome of years of ceaseless experiment and research.
- They are the most accurate coils ever made, accurate to a degree never before attained.
- Built to the highest standard of engineering precision, every coil is thoroughly tested and guaranteed.
- Insist on Ferrocart coils—the coils made by Colvern.
- Full details of Ferrocart coils are given in our Radio list No. 12. Send for a copy—it's free!

Made under licence from the patentee, Hans Vogt.

Specified for "The Wireless World" "A.V.C. Straight Four." 1 set F10, F11, F12, F13 ganged at 50/- per set.  
**COLVERN LIMITED, MAWNEYS ROAD, ROMFORD, ESSEX.**  
 London Wholesale Department: 150, KING'S CROSS ROAD, LONDON, W.C.1.

## COLVERN

## Brilliant Performance from any Circuit

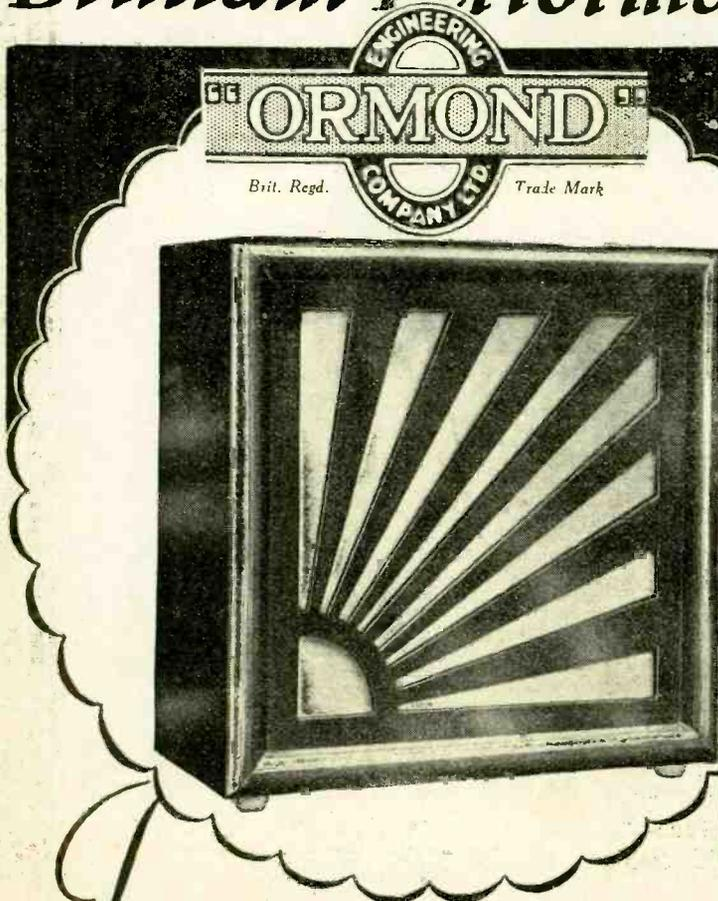

...Solve your 'additional' Loudspeaker problem with the

# ORMOND "POPULAR"

YOU need an extra 'speaker to enable you to listen in other rooms besides that in which the receiver is situated. You want first-class performance, of course. And you don't want to pay a great deal. That is your problem. HERE is the answer—the Ormond Popular Loudspeaker.

Whatever circuit you are using, the "Popular" will link up with it in perfect harmony, and render reproduction of irreproachable quality. Yet its price is marvellously low. A truly typical Ormond value. It comprises Ormond's famous four-pole Adjustable Unit, together with cone of specially selected material, incorporated in a handsome Oak cabinet.

IN OAK  
**29'6**

For Normal Outputs Cat. No. R/452.  
 For High Impedance Pentodes Cat. No. R/452z.  
 For Class B and Q.P.P. Cat. No. R/452C.T.

THE ORMOND ENGINEERING CO., LIMITED  
 Ormond House, Rosebery Avenue, London, E.C.1.

Telephone: Clerkenwell 5334-5-6 & 9344-5-6.  
 Telegrams: "Ormondengi, Isling."

JOE PUNCH - POWER & PURITY!

Mention of "The Wireless World," when writing to advertisers, will ensure prompt attention.

# A Ferranti Transformer cannot be cheap

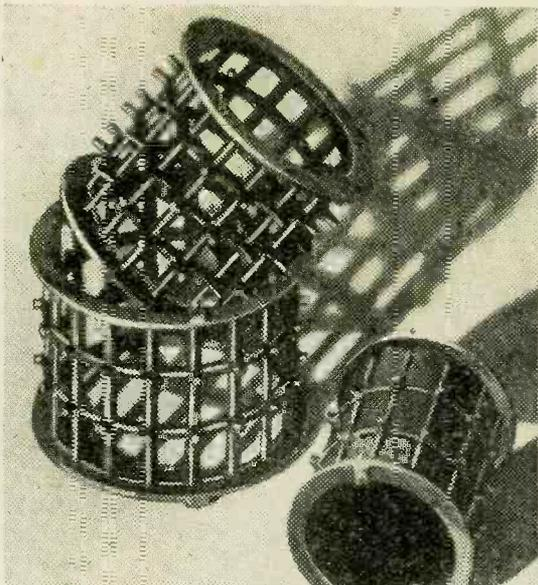

Here are the three special insulating formers with their moulded-in pegs for external connection anchorage. Note the air-spacing for windings, and the absence of paper, cotton, or other hygroscopic material which causes breakdown.



These are the wound formers—three and a half miles of wire in an AF5! Winding is done by compressed air turbines driven machines—thus avoiding all trace of mechanical stress which is inseparable from direct driving.

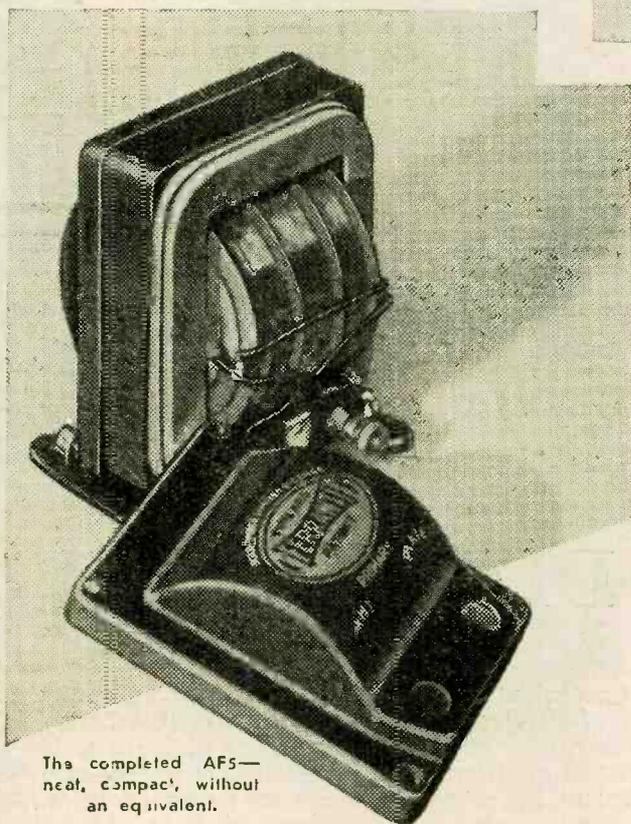

The completed AF5—neat, compact, without an equivalent.

It is true to say that every part of a Ferranti Transformer is an engineering masterpiece involving expert design, experienced choice of material, and meticulous care in workmanship.

As an instance, take only the windings of an AF5. (A similar structure is employed in nearly all Ferranti Audio and Output Transformers.) The accompanying photos tell their own story; the captions give interesting details.

Add to these points the fact that Ferranti Transformers were the first to give good results even in the early days when the characteristics of valves made quality reproduction far more difficult than it is to-day, and you will know just why FERRANTI Transformers are the first choice of expert radio engineers, and why it is well worth paying a little extra for a quality product.



PRICES:		
AF3	Ratio 1/3.5 Inductance 220/60 Henrys	25/-
AF5	Ratio 1/3.5 Inductance 260/80 Henrys	30/-
AF6	Ratio 1/7 Inductance 50/90 Henrys	30/-
AF7	Ratio 1/1 1/4 Inductance 400/100 Henrys	30/-
AF8	Ratio 1/3.5 Inductance 20/45 Henrys	11/6
AF10	at 8/6 is of similar, though not identical, structure.	

Write for Lists  
 FERRANTI Ltd. HOLLINWOOD, LANCASHIRE  
 London: Bush House, Aldwych, W.C.2

# BLUE SPOT thrives on comparison

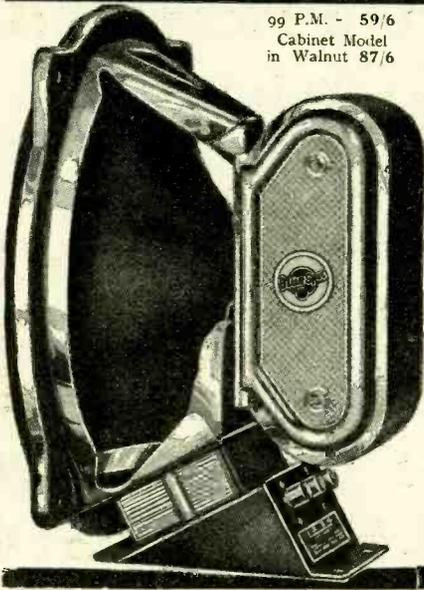

99 P.M. - 59/6  
Cabinet Model  
in Walnut 87/6

**YOU** can test the Blue Spot Speakers in any way you like and the result is always the same—Blue Spot at the top, the first and final choice.

In appearance Blue Spot takes an easy lead. In construction Blue Spot materials and workmanship are unequalled by any. The result is a degree of performance as near to perfection as modern science has succeeded in attaining.

If you want complete reliability and satisfaction you must buy Blue Spot. Ask your dealer for a demonstration.

- MOVING COIL SPEAKERS 32/6 to 87/6  
*(Also obtainable without transformers)*
- OTHER TYPES - - - - - 12/6 to 42/-
- NEW BLUE SPOT CLASS B OUTPUT STAGE *without valve* 29/6  
*60R class B choke and Base Plate 7/6.*
- BLUE SPOT PICK-UP 33—*complete with wire wound volume control and rotating head.* Price 35/-

### USE YOUR SET TO GIVE YOU MUSIC IN EVERY ROOM

Install extra Blue Spot Speakers and have music in your Dining Room, Kitchen, Nursery, etc. It costs little. It gives you the full value from your set.

### SEND THIS COUPON TO-DAY

Write your name and address on the margin, and send in unsealed envelope (i.d. stamp) for fully illustrated catalogue No. W.W. 91. S. about Blue Spot 99 P.M. and all other lines.

**THE BRITISH BLUE SPOT COMPANY LTD.**,  
Blue Spot House, 94-96 Roseman Street, Rosebery Avenue, London, E.C.1. Telephone: *Clarksonell* 3570. Telegrams: *Bluespot, Iliff, London.* Distributors for Northern England, Scotland and Wales: H. C. Rawson (Sheffield and London), Ltd., 100, London Road, Sheffield; 22, St. Mary's Parsonage, Manchester; 177, Westgate Road, Newcastle-upon-Tyne; 37, 38, 39, Clyde Place, Glasgow.

## A Combined Diary and Reference Book for every keen Amateur

# The Wireless World DIARY for 1934

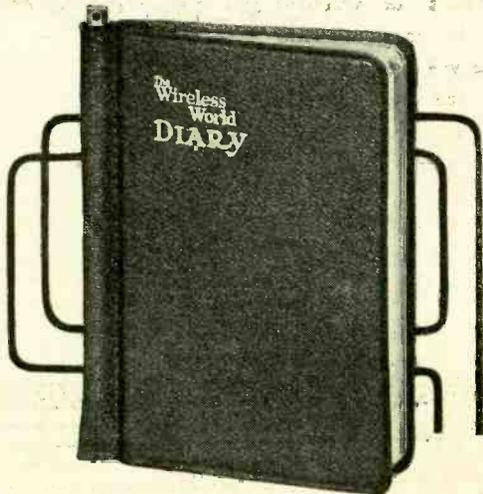

As a convenient source of information on many aspects of wireless theory and practice, this handy little Diary, now in its tenth year of publication, is unique. In addition to the usual diary pages—one week at an opening—there are 78 pages of facts, figures and explanations. These include sixteen pages of circuit diagrams of complete receivers and details of receivers, including battery economy circuits dealing with Class B, QPP, and other methods, and devices for suppressing mains interference.

Size 3½ x 4½ inches, 192 pages. Bound leather cloth, backloop with pencil.

Price 1/6 Net. By post 1/7

Compiled by the staff of "The Wireless World"

From all Booksellers, Stationers and Bookstalls or direct from the Publishers

**ILIFFE & SONS LIMITED, DORSET HOUSE, STAMFORD STREET, LONDON, S.E.1**

Mention of "The Wireless World," when writing to advertisers, will ensure prompt attention.

**Here's** **NEWS** **Free** **Blue Print** of  
 1935 DESIGN IN 1934  
 THE  
 "MATCHED PERFECTION  
 SEVEN"

introducing  
 THE NEW SUPER-HET  
**RADIOPAK**  
 THE BIGGEST ADVANCE  
 IN WIRELESS DESIGN

British Radiophone, as originators of the "Radiopak" are able to offer the Home Constructor a circuit far in advance of present day design, embodying many features not previously available.

The "Matched Perfection Seven" is a "single knob" Super-Heterodyne Battery receiver of outstanding performance. Incorporating the new R.F. Super "Radiopak," 2 Westectors, real Automatic Volume Control and Pentode output, this receiver is characterised by knife-edge selectivity without side-band "cut-off" sensitivity, volume and range as well as quality of the highest order.

radiophone "Matched Perfection" is famous as the best in Radio and is the choice of manufacturers of repute and practically all well-known designers. It is the perfect factory matching of the new R.F. Super "Radiopak" that is chiefly responsible for the amazing performance of the "Matched Perfection Seven."

## FREE BLUE PRINT

Any Radiophone dealer will supply you with a free copy of a blue print for making up this new Radiophone receiver and will show you the new Super-Het Radiopak. See your dealer to-day. Get your free Blue Print to-day.

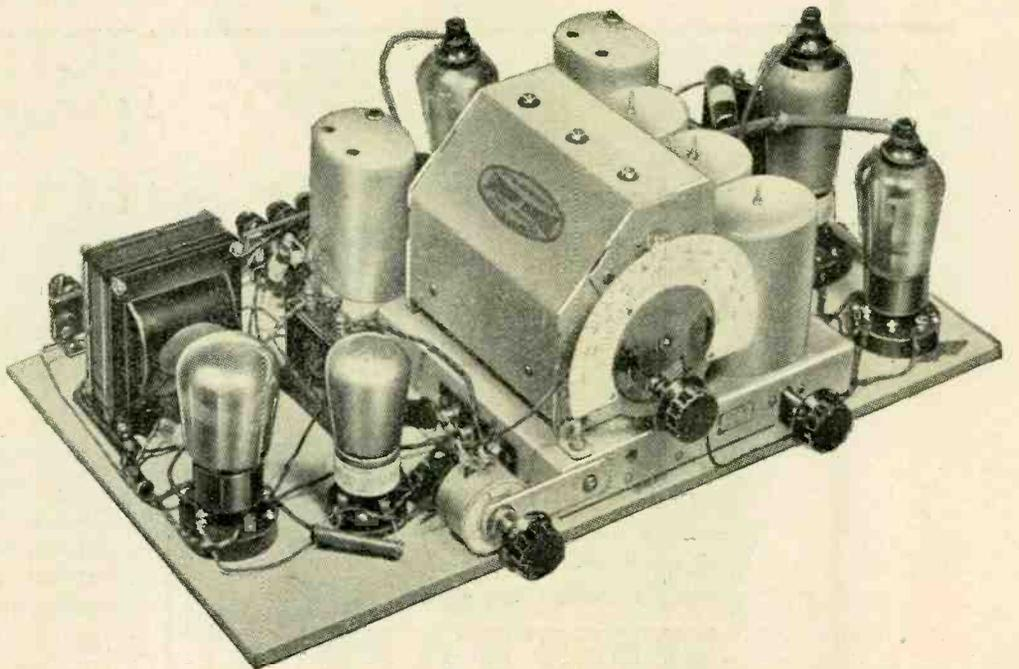

**BRITISH RADIOPHONE LIMITED**

**ALDWYCH HOUSE, ALDWYCH, LONDON, W.C.2.**

Telephone: Holborn 6744.

**CUT THIS COUPON FOR PARTICULARS**

Write your name and address in the margin and post the coupon in an open envelope together with 3d. in stamps to cover postage. You will receive by return full particulars and Blue Print of the new Radiophone Receiver.

# Perfect Reproduction

Expressions commonly used to describe the performance of a loud-speaker include "tonal beauty, high quality, purity," and so on.

They suggest proportionate rather than maximum efficiency, and are better used in connection with instruments that actually create musical notes, such as violin or piano.

The function of a loudspeaker is not merely to render speech and music with "tonal beauty" or "purity," but to re-create the actual performance.

Reproduction that emphasises certain notes at the expense of others, and cuts out low or high notes altogether, is not re-creation. It is at best a travesty.

Perfect reproduction is, after all, a re-creation of the original performance. It alone can completely satisfy, because it gives the illusion one is listening to the actual performance.

This perfection is inherent in every R. & A. Reproducer, as a demonstration will convincingly prove.

## R & A ALPHA

P.M. MOVING COIL REPRODUCER DE-LUXE

The R. & A. "Alpha" Reproducer is designed to re-create broadcast speech and music, devoid of objectionable resonances, inequalities in musical balance, or high and low note cut-off.

Its high flex density (9,000 lines per sq. cm. in the gap) permits satisfactory operation with comparatively low inputs, and it will accept up to 7 watts undistorted A.C. without distress.

The unique system of independent diaphragm and speech coil assembly ensures immunity from damage and permanently trouble-free operation.

2 MODELS:—  
STANDARD,  
for Triodes and  
Pentodes, and  
MODEL "B"  
for Class "B"  
and Q.P.P.

52/6

R. & A. Reproducers range in price from 21/- to 70/-. Write for 1934 list. Your dealer can supply and demonstrate.

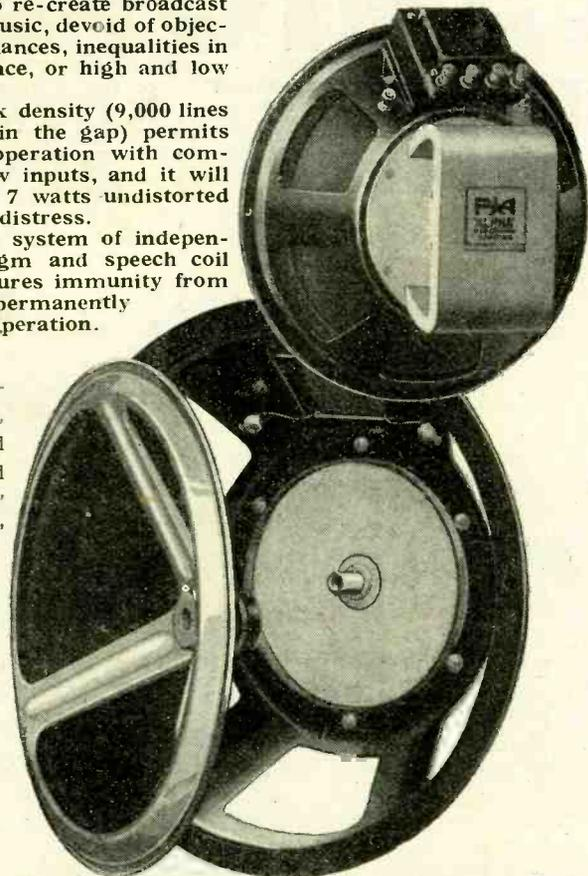

**BRITAIN'S  
FOREMOST  
REPRODUCERS**  
REPRODUCERS & AMPLIFIERS Ltd., Wolverhampton

RA/321/Hol/105

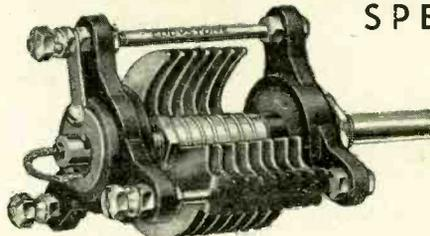
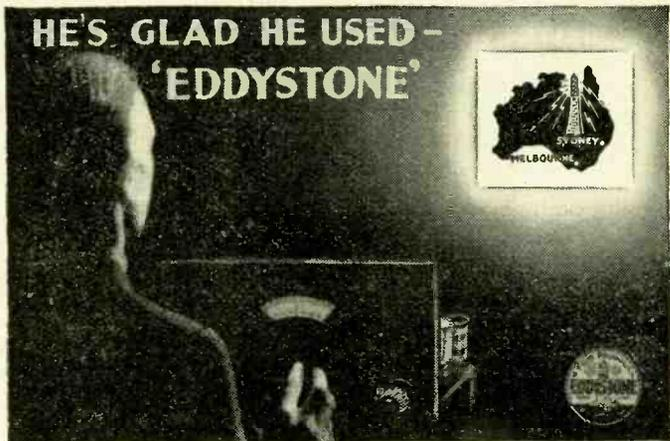

**EDDYSTONE**  
"SCIENTIFIC" S.W. CONDENSER

Type 942.

35 m.mfd. 6/-	100 m.mfd. 7/-
60 m.mfd. 6/6	150 m.mfd. 7/6
	(:00015 mfd.)

STRATTON & CO., LTD.,  
Bromsgrove St., Birmingham.  
London Service Depot—  
WEBB'S RADIO STORES,  
14, Soho St., Oxford St., W.1.

**SPECIALISED  
DESIGN  
— PAYS**

Good results always follow good design. "EDDYSTONE" short wave parts are basically sound for their purpose. This patented "EDDYSTONE" S.W. Variable Condenser is an outstanding example. Noiseless bakelite bearings, soldered brass vanes, low self-capacity, non-inductive insulated pigtail, low H.F. resistance and special Isolex endplates, are some of its features. You cannot fit a better S.W. Condenser.

**EDDYSTONE**  
SHORT-WAVE COMPONENTS

## DICTIONARY of WIRELESS TECHNICAL TERMS

Compiled by S. O. Pearson, B.Sc., A.M.I.E.E., and issued in conjunction with "THE WIRELESS WORLD"

**SECOND EDITION**

Revised and brought up to date

THIS handy volume is very much more than a Dictionary. It not only takes the technical terms of wireless and explains their meaning, but in doing so it concentrates into a small space a large amount of information on wireless subjects. It has become, in fact, a compendium of current wireless knowledge, and an invaluable handbook for all who are interested in wireless transmission and reception. Diagrams and illustrations are freely interspersed throughout the book to amplify the explanations of the text.

272 pp., bound in cloth boards  
Size 5 by 3 inches

Price 2/- net. By post 2/2

From all leading booksellers or direct from the Publishers

ILIFFE AND SONS LTD.  
Dorset House, Stamford Street, London, S.E.1

W.W.48.

Mention of "The Wireless World," when writing to advertisers, will ensure prompt attention.

Full  
vision  
dials

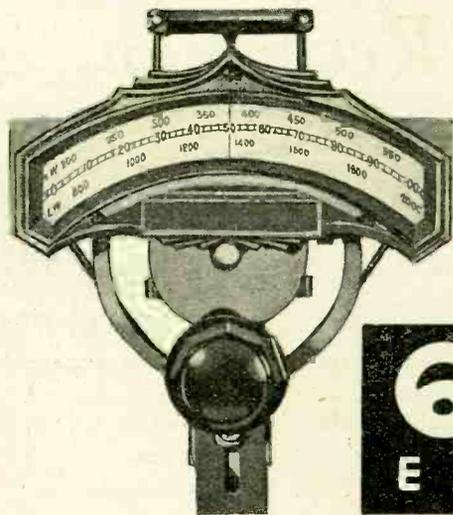
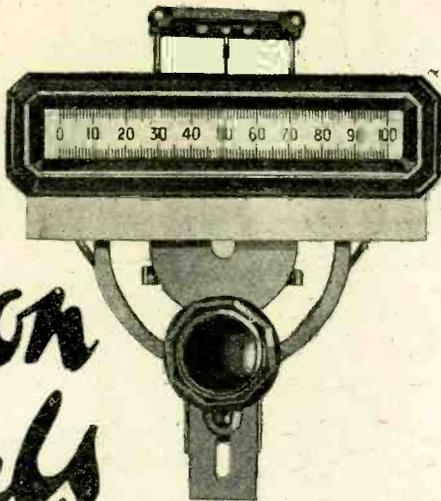

W 330 and 333 are the latest form of the straight-line dial. With these dials the scale is always in view and is traversed by a moving pointer.

**6/6**  
EACH

UTILITY were the first straight-line dials offered to the constructor. Naturally there are others: the idea was so good it was bound to be copied.

But here is a new Utility full-vision dial, the finest dial now available. The friction drive gives perfect control of any type or size of condenser and is guaranteed free from backlash. The bold scale is always in full view and the hair-line pointer enables very accurate readings to be made. The new dial is supplied in two types, straight line and oval, and with each the pointer remains upright at all positions. This important refinement adds to our assembling difficulties but ensures accurate readings for you by avoiding parallax errors.

The dials can be supplied marked in degrees 0-100 or in wavelengths.

From your dealer or post free from the makers.

Write for a copy of our new catalogue; it contains full details of our complete range of dials, condensers and switches.

**WILKINS & WRIGHT, LTD.**

UTILITY WORKS, HOLYHEAD RD., BIRMINGHAM,  
London Agent: E. R. MORTON LTD., 11, Newman Street,  
Oxford Street, W.1.



Belmont

THE "HI-LIFE" GIVES YOU 50.2% EXTRA LIFE



"UP AND DOING"

OTHER MAKES "DOWN AND OUT"



"DOWN AND OUT" OTHER MAKES CANNOT MAINTAIN THEIR OUTPUT



YOU GET THIS FREE

**50.2% LONGER LIFE**

This is a true illustration of a test made by a famous British set maker. He knew our reputation, he knew the long life and high quality of Hellesen batteries, but he made this test to convince himself. And the result showed that Hi-Life batteries give 50.2% longer life than any other. Over 40 years' experience in battery manufacture has produced this amazingly high standard of performance, has enabled you to buy 50.2% longer life, greater capacity and larger output at a price competitive with any other quality battery on the market.

BRITISH MADE BY **11/-** BRITISH LABOUR



**HELLESENS**

HI-LIFE BATTERY

Hellesens Limited, Morden Road, South Wimbledon, London, S.W.19

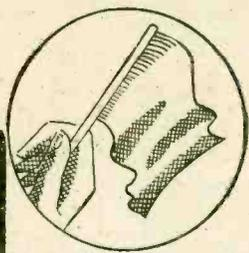

# The Flag that signals

"All Clear"

for **BETTER** Radio Reception

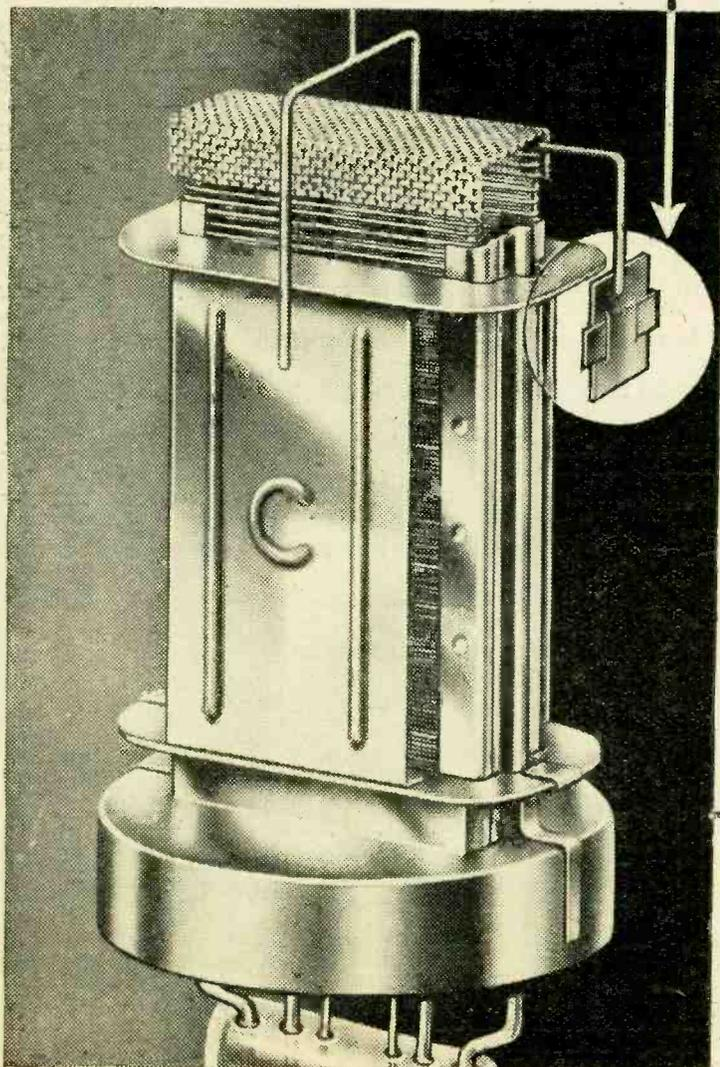

A flag in a Cossor Valve? Nonsense! But it's true. It plays a big part in maintaining Cossor consistency and reliability.

In making Radio valves, the highest degree of vacuum is essential. The very last traces of air must be pumped out of the bulb. But even this is not enough. Within, there may still be gaseous matter which would be liberated when the valve is in use.

And so, Cossor uses a flag carrying a special alloy. During the process of pumping, the anode is raised to a high temperature. This causes gaseous matter to be liberated. Finally, the flag is made incandescent by the application of high frequency eddy current. This causes the alloy to volatilize and absorb the last traces of any residual gas. Thus all impurities are removed—and an exceptionally high vacuum created. Here is another process—another safeguard—used by Cossor to ensure Better Radio Reception.

## COSSOR VALVES

To A. C. COSSOR LTD., Melody Dept., Highbury Grove, London, N.5

Please send me free of charge, a copy of  
the Cossor 72-page Wireless Book B.V.33.

Name .....

Address .....

W.W. 24/11/33-.....

♥ 4045

Mention of "The Wireless World," when writing to advertisers, will ensure prompt attention.

# The Wireless World

THE  
PRACTICAL RADIO  
JOURNAL  
23rd Year of Publication

No. 743.

FRIDAY, NOVEMBER 24TH, 1933.

VOL. XXXIII. No. 21.

Proprietors: ILIFFE & SONS LTD.

Editor:  
HUGH S. POCOCK.

Editorial,  
Advertising and Publishing Offices:  
DORSET HOUSE, STAMFORD STREET,  
LONDON, S.E.1.

Telephone: Hop 3333 (50 lines).  
Telegrams: "Ethaworld, Watloo, London."

COVENTRY: Hertford Street.

Telegrams: "Cyclist, Coventry." Telephone: 5210 Coventry.

BIRMINGHAM:

Guildhall Buildings, Navigation Street, 2.

Telegrams: "Autopress, Birmingham." Telephone: 2970 Midland (3 lines).

MANCHESTER: 260, Deansgate, 3.

Telegrams: "Iliffe, Manchester." Telephone: Blackfriars 4412 (4 lines).

GLASGOW: 26B, Renfield Street, C.2.

Telegrams: "Iliffe, Glasgow." Telephone: Central 4857.

PUBLISHED WEEKLY. ENTERED AS SECOND  
CLASS MATTER AT NEW YORK, N.Y.

Subscription Rates:

Home, £1 1s. 8d.; Canada, £1 1s. 8d.; other  
countries abroad, £1 3s. 10d. per annum.

*As many of the circuits and apparatus described in these  
pages are covered by patents, readers are advised, before  
making use of them, to satisfy themselves that they would  
not be infringing patents.*

## CONTENTS

	Page
Editorial Comment .. .. .	401
The Wireless World A.V.C. Straight Four .. .. .	402
Battery Economy with the Westector .. .. .	405
Ultra Short-wave Superheterodynes	406
News of the Week .. .. .	408
FOREIGN PROGRAMME	
SUPPLEMENT, pp. I—XXIV	
Broadcast Brevities .. .. .	409
New Apparatus Reviewed .. .. .	410
Television Explained .. .. .	411
Letters to the Editor .. .. .	413
The Faraday All-wave Super- heterodyne .. .. .	415
Readers' Problems .. .. .	416

## EDITORIAL COMMENT

### Calibrating the Receiver

*A Great Opportunity in  
January*

**T**HE nights of January 14th and 15th next should be of unique interest to readers of *The Wireless World*. As we were able to reveal last week, the International Broadcasting Union has wisely decided that the great transfer of wavelengths under the Lucerne Plan shall be conducted as far as possible in an orderly fashion under the direct supervision of the Union's own checking station at Brussels.

The magnitude of the operation is without parallel in the history of wireless. Whereas, with the inception of the Prague Plan six years ago, there were 173 stations to be accounted for, now there are no fewer than 230—many of higher power—and M. Brailard, the technical secretary of the Union, will add fresh laurels to his already established reputation as "ether policeman" if the plan of operations is successful.

### *Orderly Progression*

The attractiveness of the plan, apart from the probability that it will avoid the comparative chaos which attended the introduction of the Geneva and Prague wavelength schemes, lies in the possibility that every European station may, at the start, at any rate, be working on a known wavelength, guaranteed accurate by the Brussels wavemeter. Listeners will thus have an unprecedented opportunity to calibrate their own receivers. On the actual night of the transfer, beginning at Zero Hour (11 p.m. G.M.T.) certain high power stations, easily receivable in this country, will be transmitting announcements as and when each station is

calibrated at the control point. Most British listeners will probably tune-in Radio-Paris, which will be recording the progress of the change-over at the broadcasting stations in Belgium, Spain, France, Great Britain, Ireland, Iceland, Luxembourg, Morocco, Holland, Portugal and Switzerland. It will then be possible to "nail down" these transmitters one by one on the tuning dial of the receiver in reasonable confidence that the wavelengths are actually as stated.

### *Long-wave Prospects*

No doubt some listeners will seek an opportunity to follow the wave changes as they are being made in Central and Eastern Europe, but the purpose of calibration will be served if some twenty or more nearer stations can be accurately observed.

Minor wavelength changes are bound to follow as and when the Lucerne Plan is put to practical test, but the point of essential importance is that every listener who has carefully followed the checking process will have a receiver calibrated throughout the tuning scale. To achieve such an end it will be worth while on January 14th and 15th, misquoting Milton, to "shun delights and live laborious nights."

Unhappily these bright prospects are confined to the medium waveband. Of the twelve countries using long waves, five are non-signatories to the Lucerne Plan, and it is difficult at the moment to see how any arrangement of the long waves can be satisfactory until all long-wave users can be brought to understand that the old roving days are over so far as European broadcasting is concerned.

Perhaps the delinquents will bow to the inevitable, as has just been done by the recalcitrants on the medium waves, by adopting the Lucerne Plan "without any obligation."

The Wireless World

# A.V.C. STRAIGHT FOUR

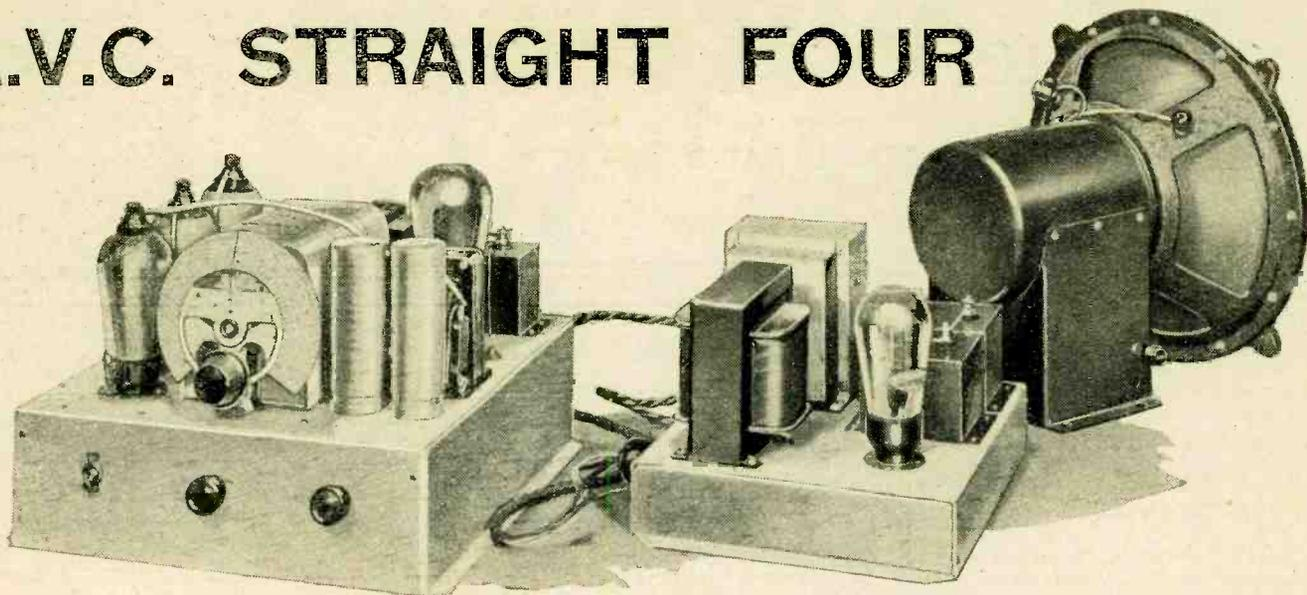

## A Highly Selective A.C. Receiver Including Iron-Cored Coils

**T**HE introduction of iron-cored tuning coils has permitted such a great increase in the selectivity of the straight set that it can now approach that of the superheterodyne, and once more take its place as a satisfactory receiver for distant reception. The A.V.C. Straight Four includes four such circuits, and automatic volume control is fitted to reduce the effects of fading.

**A**LTHOUGH the superheterodyne has largely ousted the straight set where high selectivity and sensitivity are required, this is in great measure due to a trend which set in before the advent of compact high-efficiency tuning coils. This does not mean, of course, that the trend is in a wrong direction, for the characteristics of the superheterodyne are such that its popularity would have been inevitable. Had iron-core coils been developed earlier, however, it is safe to say that the straight set would not have been displaced to such a large degree.

One of the outstanding advantages of the straight set is its freedom from second channel interference, and, in the eyes of many, this is sufficient to compensate for the somewhat lower adjacent channel selectivity as compared with the superheterodyne. Furthermore, the ganging adjustments are simpler.

However efficient a coil may be, it becomes of no avail if it be connected in a circuit incorrectly. The connection of any components to a tuned circuit inevitably lowers its efficiency to some degree, but such additional components are essential if any use is to be made of the circuit.

The problem of design, therefore, resolves itself into finding that method of connection which introduces a minimum of loss while still retaining efficiency.

A glance at the circuit diagram of Fig. 1 shows that, in the case of the aerial tuned circuit, the first valve is connected across the whole of the coil, for the input impedance of a screen-grid H.F. amplifier is quite high and it throws little damping on the tuned circuit. The aerial, however, is connected to a tapping on the coil which is so placed that an efficient coupling is obtained with a minimum of damping. In order that the ganging may

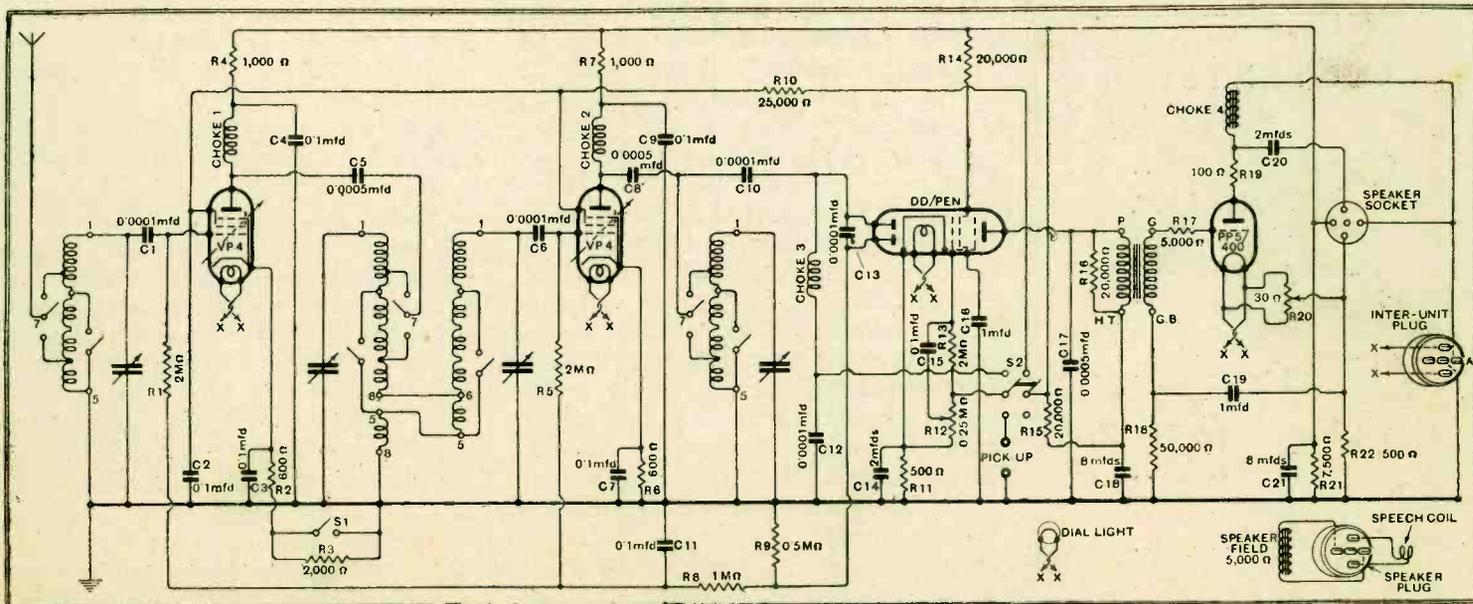

Fig. 1.—The circuit diagram of the receiver unit. It will be noted that the band-pass filter is fitted between the two H.F. stages for which variable-mu H.F. pentodes are employed. The detector is a duo-diode-pentode.



**The A.V.C. Straight Four—**

the initial smoothing in conjunction with the 4  $\mu$ F. condenser C22. The potential available across this condenser is about 430 volts and is applied directly to the output valve. A certain drop in voltage occurs in the output choke No. 4 (Fig. 1) so that the true anode voltage on the output valve is slightly below its maximum rating of 400 volts.

Additional smoothing is required for the H.T. supply to the early valves, and this is obtainable from the speaker field in conjunction with the 8  $\mu$ F. electrolytic condenser C21. The field has a resistance of 5,000 ohms, and the current through it is slightly under 50 milliamperes, so that the voltage drop across it is about 240 volts, and a supply of 190 volts is available for the nominally 200 volts line.

The anodes of the H.F. valves are fed from this through 1,000 ohms decoupling resistances R4 and R7, with decoupling condensers C4 and C9 joined to earth. The screen grids, however, are not fed from a potentiometer in the usual way, but merely through a single dropping resistance. This is made possible by the use of H.F. pentodes for the H.F. stages, since the screen current in these valves is much more constant than usual. A further point in favour of this method of feeding the screens lies in the increased input handling capacity of the valves at high A.V.C. bias voltages, although this is to some extent offset by the necessity for using a higher bias for a given reduction in signal strength. These effects, of course, are brought about by the fact that the screen voltage rises as the bias is increased. It should be noted that one pole of the radio-gramophone switch is so connected that on gramophone it open-circuits the screen feed, thus effectively preventing any break-through of radio signals when records are being reproduced.

**The Mains Equipment**

The screen of the duo-diode-pentode is fed from the 200 volts line through a 20,000 ohms resistance R14, with a 1  $\mu$ F. decoupling condenser C16. Minimum bias on the H.F. stages is provided by the drop of voltage along the 600 ohms resistances R2 and R6, which are shunted by 0.1  $\mu$ F. condensers C3 and C7. In the case of the first H.F. stage it will be noted that the cathode circuit includes also a 2,000 ohms resistance R3 which can be short-circuited by the switch S1. The purpose of this is to avoid any possibility of distortion due to overloading when listening to the local station. For reception of a powerful station the switch can be opened and the initial sensitivity

of the set reduced, thus lessening the strain upon the A.V.C. system.

It will have been observed that the mains transformer has only a single winding for the heater supply to all the valves, apart from the mains rectifier. Hitherto, it has been necessary to employ a separate winding for a directly heated output valve, for its bias voltage otherwise appears as

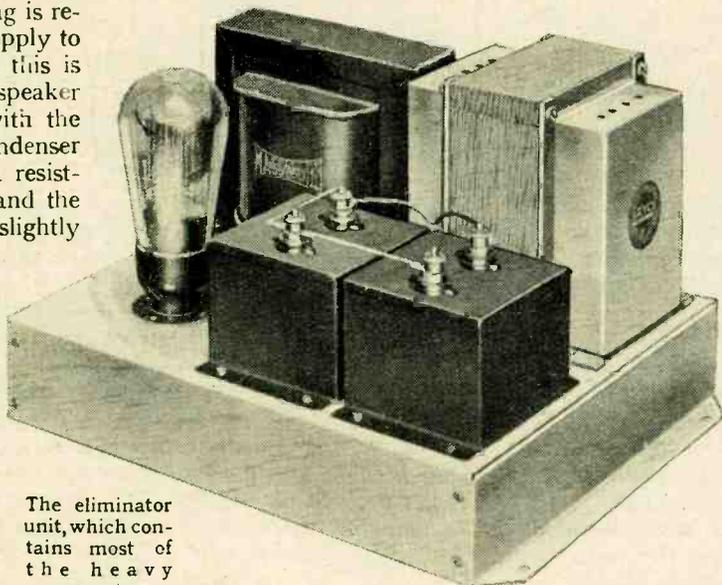

The eliminator unit, which contains most of the heavy apparatus.

a potential difference between the heaters and cathodes of the other valves. Recent progress in valve development, however, has made this unimportant, and it is now possible safely to adopt a single transformer winding for all valves.

The assembly of the components, wiring up, and the operation of the receiver will be dealt with in next week's issue.

**THE LIST OF PARTS.****Receiver Unit**

- |   |  |
|---|--|
| 1 4-gang condenser  | Polar "Star Minor"                     |
| 1 Dial for above  | Polar "Full-Vision" Semicircular Drive |
| 1 Set of 4 Ferrocort coils on chassis, consisting of F.10, F.11, F.12 and F.13  | Colvern                                |
| 3 Screened H.F. chokes, Ch1, Ch2, Ch3   | Bulgin H.F.9                           |
| 2 Electrolytic condensers, 8 mfd., 450 volts peak working, C18, C21   | Dubilier                               |
| (Peak, T.C.C.)  |  |
| 1 Fixed condenser, 2 mfd., 550 volts, D.C. working, in rectangular metal container, C20   | Dubilier L.C.G.                        |
| 1 Fixed condenser, non-inductive, 2 mfd., 250 volts, D.C. working, in cylindrical aluminium container                                   | C14 Dubilier 9200                      |
| 2 Fixed condensers, non-inductive, 1 mfd., 250 volts, D.C. working, in cylindrical aluminium containers, C16, C19                       | Dubilier 9200                          |
| 7 Fixed condensers, non-inductive, 0.1 mfd., 250 volts, D.C. working, in cylindrical aluminium containers, C2, C3, C4, C7, C9, C11, C15 | Dubilier 9200                          |
| 5 Fixed condensers, 0.0001 mfd., C1, C6, C10, C12, C13  | Dubilier 665                           |
| 2 Fixed condensers, 0.0005 mfd., C5, C8   | Dubilier 665                           |
| 1 Fixed condenser, 0.0005 mfd., C17   | Dubilier 670                           |
| 1 Resistor, 30 ohms, R20  | Claude Lyons "Humdinger"               |
| 1 Wire-wound resistance, 7,500 ohms, 20 watts, R21  | Bulgin PR.10                           |
| 1 Resistance, 100 ohms, 1 watt, R19   | Erie                                   |
| 1 Resistance, 500 ohms, 1 watt, R11   | Erie                                   |
| 1 Resistance, 500 ohms, 3 watts, R22  | Erie                                   |
| 2 Resistances, 600 ohms, 1 watt, R2, R6   | Erie                                   |
| 2 Resistances, 1,000 ohms, 1 watt, R4, R7   | Erie                                   |
| 1 Resistance, 2,000 ohms, 1 watt, R3  | Erie                                   |
| 1 Resistance, 5,000 ohms, 1 watt, R17   | Erie                                   |
| 3 Resistances, 20,000 ohms, 1 watt, R14, R15, R16   | Erie                                   |
| 1 Resistance, 25,000 ohms, 1 watt, R10  | Erie                                   |
| 1 Resistance, 50,000 ohms, 1 watt, R18  | Erie                                   |
| 1 Resistance, 500,000 ohms, 1 watt, R9  | Erie                                   |
| 1 Resistance, 1 megohm, R8  | Erie                                   |
| 3 Resistances, 2 megohms, R1, R5, R13   | Erie                                   |
| (Dubilier, Graham Farish, Claude Lyons, Seradex.)   |  |
| 1 Tapered volume control, 250,000 ohms, R12   | Magnum (Claude Lyons, Watnet.)         |
| 1 L.F. transformer, 1 : 3½  | Ferranti AF5                           |
| 1 L.F. choke, 20 henrys, 60 mA., Ch3  | R.I. DY51                              |
| 4 Valve holders, 5-pin  | Clix Chassis Mounting Standard Model   |

- |  |                                      |
|--|--------------------------------------|
| 1 Valve holder, 7-pin  | Clix Chassis Mounting Floating Model |
| 1 Double-pole changeover switch, S2  | Bulgin S.98                          |
| 1 On-off toggle switch, S1   | Bulgin S.102                         |
| (Claude Lyons.)  |                                      |
| 1 5-way connector  | Wilburn                              |
| 1 5-way battery cable, with twin 70/30 leads   | Harbros                              |
| 2 5-pin plugs  | Bulgin P.3                           |
| 2 Knobs  | Bulgin K.14                          |
| 4 Ebonite shrouded terminals, A., E., pick-up (2)  | Belling-Lee "B"                      |
| 2 Lengths screened sleeving  | Harbros                              |
| 1 Metal chassis, complete with screws, nuts and washers  | Haynes Radio                         |
| 6 Lengths Systoflex, 2 ozs. No. 20 tinned copper wire, etc.  |                                      |
| Valves:—2 Mullard VI4, or Ferranti VPT4, 1 Cossor DD/Pen., 1 Mazda PP5/400 or Marconi or Osram PX25. |                                      |

**Power Unit**

- |   |                                      |
|---|--------------------------------------|
| 1 Mains transformer, Primary: 200 to 250 volts, 50 cycles; secondaries: 450-0-450 volts, 120 mA., 4 volts 2.5 amp. centre-tapped; 4 volts 5/6 amp. With screened primary. | Bryce AB573/c                        |
| 1 L.F. smoothing choke, 26 henrys, 120 mA., 140 ohms, D.C. resistance, Ch5  | Savage "Massicore" RC27M             |
| 2 Fixed condensers, 4 mfd., 550 volts, D.C. working, in rectangular metal containers, C22, C23  | Dubilier L.C.G.                      |
| 2 Valve holders, 5-pin  | Clix Chassis Mounting Standard Model |
| 1 5-way connector   | Wilburn                              |
| 1 Metal chassis, complete with screws, nuts and washers   | Haynes Radio                         |
| 2 Lengths Systoflex, 1 oz. No. 20 tinned copper wire, etc.  |                                      |
| 1 Loud speaker, with 5,000 ohms field, and high impedance speech coil for PP5/400 valve   | Baker's S.P.D. Black Cone            |
| Valves:—1 Marconi or Osram MU14.  |                                      |

**THE RADIO INDUSTRY**

AS befits members of a new industry, Partidge, Wilson & Co. (makers of Davenset apparatus) apparently hold progressive views on the employers' obligations towards employees. Their workpeople have just been given an all-round increase of 5 per cent. in wages. This is the second general increase during the year, and, in addition, a successful profit-sharing scheme is in operation.

The production of McMichael receivers for the month of October constituted a record for the firm. To celebrate the event, Mr. Leslie McMichael, a well-known figure both in amateur and trade circles, himself engraved the serial number plate for the last set to pass out of the test-room on October 31st.

The Edison Swan Electric Co., Ltd., are to market electrically operated Bulle clocks, both in mains- and battery-driven models.

The Sunbeam Electric Co. is shortly to occupy a new and larger factory in Park Royal Road, London, N.W.10.

The latest publication issued by Claude Lyons, Ltd., of 76, Oldhall Street, Liverpool, is justly entitled "A Helping Hand to Set Constructors." In addition to full technical descriptions of the many components and accessories produced by this firm, it includes many pages of circuit diagrams and technical notes. Readers may obtain copies by sending 3d. in stamps.

New Mullard valves.—Indirectly heated power rectifiers, types IW2 and IW3, giving rectified outputs of 60 milliamperes at, respectively, 250 volts and 350 volts. As compared with the ordinary directly heated rectifier, the outstanding advantage of this new type is that an initial voltage rise, with consequent risk of damage to condensers, is avoided.

"This Year of Radio" is the title of an unusual and highly informative catalogue issued by Alfred Imhof, Ltd., 112-116, New Oxford Street, London, W.C.1, the well-known gramophone and radio dealers. All popular sets, radio-gramophones, and accessories are described at length; there are several "magazine" articles, and space is devoted to the "service" policy of the firm.

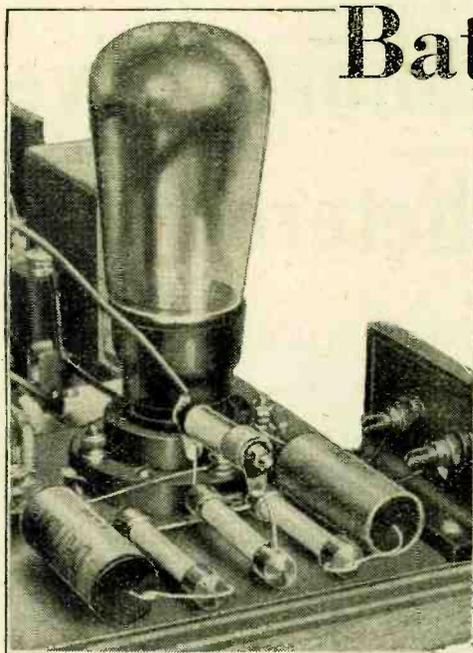

# Battery Economy with the "Westector"

## Automatic Bias Adjustment in the Output Stage

*THE majority of this season's battery receivers are fitted with Class "B" or Q.P.P. output stages which have superseded the single output valve with normal bias. The conversion of existing sets for battery economy is, however, a comparatively simple and inexpensive process if use is made of the latest metal oxide rectifiers.*

The principle of operation will be best understood by reference to Fig. 1, which shows a pentode output valve preceded by resistance-capacity coupling and feeding a moving-coil loud speaker. It will be found that pentodes give the best results in circuits of this type, as they show a better range of control for a given quiescent current. Transformer coupling could equally well be employed, but is not absolutely necessary as it is in the case of Class "B" output.

result in bottom bend rectification due to insufficient reduction of the standing bias, while too low a value will cause the valve to run to grid current. A certain amount of distortion is bound to occur in any type of quiescent output stage, but by judicious compromise in the choice of component values the harmonic distortion can be kept low over a considerable range of output power.

The table shows suitable values for  $R_1$  and relevant operating conditions for a number of popular 2-volt battery output valves.

### How the Bias is Derived

**A**LTHOUGH the majority of economical output stages employ two valves in some form of push-pull arrangement, it is quite possible to achieve comparable results with a single output valve. A valve biased to the middle of the straight portion of its characteristic is always consuming H.T. current at the rate required for its maximum power output. During the greater part of the time that the set is in operation a high bias and consequently a much lower average current can be tolerated without introducing appreciable distortion.

The essence of the scheme lies in tapping off a small fraction of the L.F. output, rectifying it and applying the resultant voltage to bias the output valve according to the power which it is called upon to handle. The Philips 832B receiver employs such an arrangement, a leaky grid triode rectifier being used to regulate the control bias in accordance with the input voltage.

The grid bias battery should be capable of supplying approximately twice the normal bias voltage required by the valve. It is connected to the lower end of a potential divider ( $R_1, R_2$ ) which is connected to the anode through the blocking condenser  $C_1$  and by-passes a small fraction of the fluctuating output current. The effect of connecting the "Westector" across  $R_2$  is to short-circuit  $R_2$  for currents flowing upwards in the potentiometer, but to give it practically its full value for establishing a difference of potential from currents flowing downwards. The net result is the establishment of a voltage in opposition to the bias and of a strength depending on the signal. The resultant bias is led off to the grid circuit through the resistance-capacity filter  $R_3, C_2$ , the time constant of which is adjusted to give rapid response to a change of signal strength, but at the same time to prevent low-frequency voltages being fed back to the grid circuit.

The value of  $R_1$  determines the fraction of the output voltage available for control, and must be chosen with care for every type of valve. Too high a resistance will

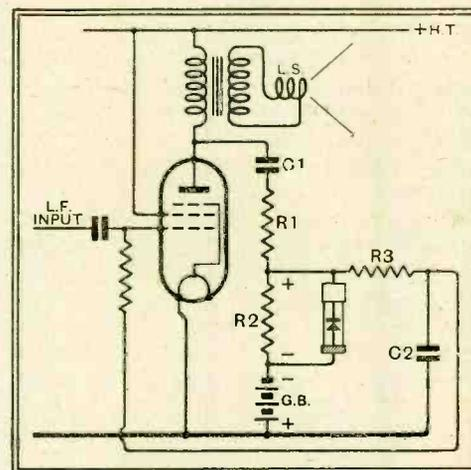

Fig. 1.—Battery economy output circuit using the "Westector" type W6. The value of  $R_1$  depends on the valve and is given in the table,  $R_2$ , 50,000 ohms;  $R_3$ , 250,000 ohms;  $C_1$ , 0.25 mfd.;  $C_2$ , 0.1 mfd.

These figures are the result of a series of experiments in the Westinghouse laboratories in which use has been made of the cathode ray tube to detect the commencement of wave-form distortion, and hence the limits between which opposing factors may be varied without prejudicing the resultant performance.

Bearing in mind that no expenditure of H.T. or L.T. current is required by a driver valve, as would be the case in Class "B," and that only three fixed resistances and two by-pass condensers are required in addition to the "Westector," there can be little doubt that this method of applying the principle of battery economy should find wide acceptance among those wishing to modernise their obsolete battery receivers.

### R.C.C. or Transformer Coupling

Where it is desired, however, to modify an existing battery receiver for economical working the "Westector" undoubtedly offers a better solution than the addition of a valve, for not only is the conversion cheap in first cost but it does not involve any further expenditure of filament current.

Valve.	Battery Volts.	$R_1$ Ohms.	G.B. Volts.	Quies. Current. mA.	Peak Current. mA.	Grid Swing. Volts.	Anode Load. Ohms.	Output mW.
Pen. 220A ..	150	100,000	16½	2.0	20	9	7,500	1,100
Pen. 220A ..	120	100,000	13½	1.3	16	7.5	9,000	700
220 P.T. ..	120	100,000	13½	1.3	16	7.5	9,000	640
Pen. 220 ..	150	150,000	9	1.6	10	4.5	17,000	500
220 H.P.T. ..								
P.T. 2 ..	150	20,000	27.0	2.0	14	14	4,000	300
P. 220A ..								
P. 2 ..								
P. 220 ..	150	60,000	13½	0.75	5.5	7	10,000	150
L.P. 2 ..								
220 P.A. ..								

Values of  $R_1$  and operating conditions for a number of 2-volt output valves.

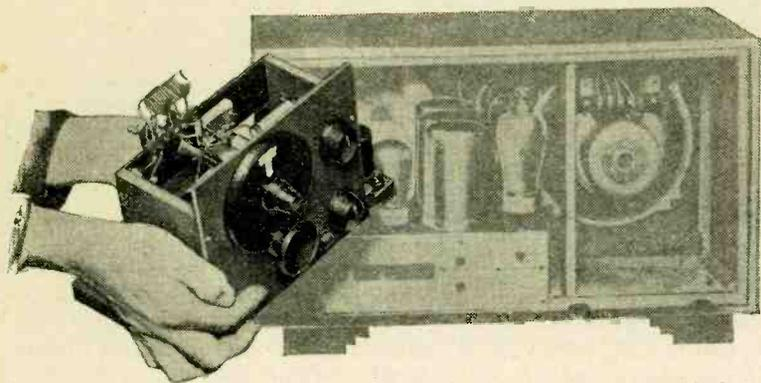

# Ultra Short-Wave Superheterodynes

By W. T. COCKING

## Receiving 5-7 Metre Television Transmissions with Simple Apparatus

RECENT articles in *The Wireless World* have shown that the only hope of high-quality television broadcasting lies in the ultra-short waveband around 5 metres. Comparatively little is yet known about the properties of these wavelengths and about the design of transmitters and receivers for specific purposes. Until recently it was believed that the range of an ultra-short wave transmitter was limited to the optical distance, that is to say, it could be received only at points within the boundary set by the horizon as viewed from the transmitting aerial. It has now been discovered, however, that this range can be greatly exceeded, and the practical limit is usually set at about twice the optical distance. In view of this, it does not seem improbable that with improvements in transmitters and receivers still greater distances may be covered in the future.

The difficulties attendant upon the design and operation of a 5-metre set will be realised when it is remembered that 5 metres represents a frequency of no less than 60,000 kc/s. At such high frequencies tuning coils and condensers assume very modest proportions, and

reception, it is evident that a highly sensitive receiver is called for.

### Advantages of the Superhet

Straight H.F. amplification is barely possible and the detector L.F. set is not sufficiently sensitive, so that the superheterodyne and the super-regenerative set vie for popularity. The latter is extremely useful, and a good example was described recently in the pages of this journal.<sup>1</sup> There are, however, limitations to the maximum sensitivity which can be ob-

*THE ultra-short waveband offers an ideal field for the further development in television, as adequate ether space is available for the higher picture frequencies necessary for good definition. The small superheterodyne adaptor described here provides the means to acquire some experience in the reception of these very short waves*

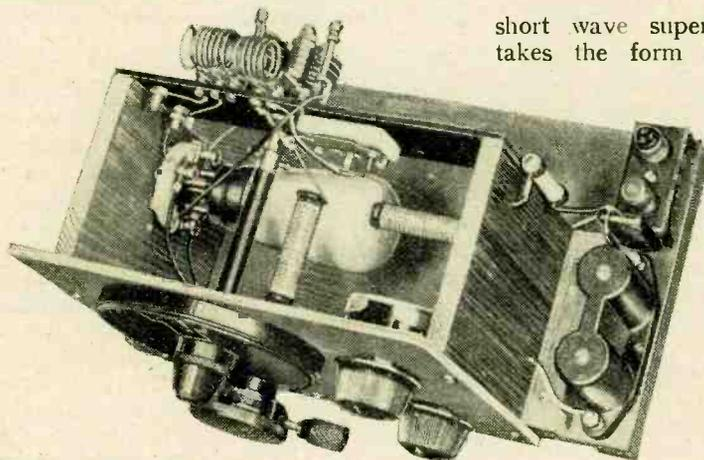

short wave superheterodyne, therefore, takes the form of a battery-operated single-valve auto-dyne frequency changer for use in conjunction with any standard battery or mains-operated receiver.

Experiment has indicated that the best general reception is obtained with the circuit arrangement shown in Fig. 1. A modified form of Hartley oscillator is used, and it will be

seen that the centre point of the coils is joined through a semi-variable condenser C<sub>2</sub> of about 70 mmfd. maximum capacity. The actual tuning capacity, therefore, consists of C<sub>2</sub> in series with the variable condenser C<sub>1</sub> of 40 mmfd.; in addition, of course, there are the various stray capacities. With the coils employed, about which more later, a tuning range of 5.5 to 7.5 metres is obtained, but this can be varied appreciably by altering the value of C<sub>2</sub>.

Experience has shown that for satisfactory operation it is necessary for the valve to slide smoothly into oscillation without threshold howl. Even although no such howl may be apparent when the valve is strongly oscillating, the best results are not obtained if the circuit conditions are such that a reduction in the anode voltage leads to howling. With most modern valves a slight positive grid bias is necessary to avoid howling, and a potentiometer R<sub>1</sub> is fitted, therefore, to enable the optimum operating point to be readily determined.

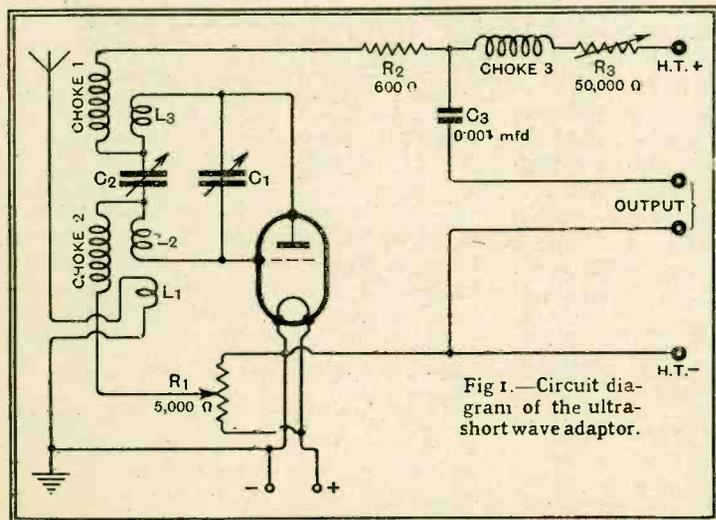

Fig 1.—Circuit diagram of the ultra-short wave adaptor.

A simple and straightforward construction is adopted as shown by this view.

tained with this system. The superheterodyne, therefore, offers the greatest hope, and this is particularly the case when high-quality reception is required, as it will be if television on this wavelength is established.

At the present time only a frequency changing unit is necessary for 5-metre

stray capacities and even the inductances of connecting leads play an important part. Since transmissions on these high frequencies are rapidly attenuated, and, so far as is known at present, reliance must be placed entirely upon the direct ray for re-

reception, since any ordinary broadcast receiver of three valves or more can be used for the I.F. amplifier, second detector and L.F. circuits. The most practical ultra-

<sup>1</sup> The Ultra Short Wave Two, *The Wireless World*, June 16th, 1933.

**Ultra Short-wave Superheterodynes—**

A variable resistance R3 is included in the anode circuit to permit a close adjustment of the anode potential. This is not

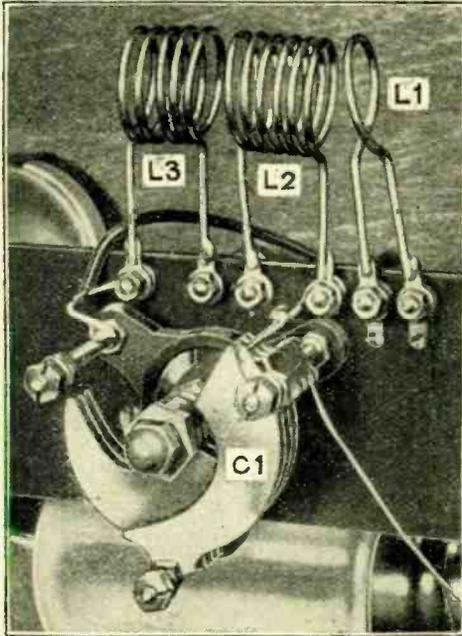

"Close-up" of small sub-panel from which the assembly of the coils and tuning condenser can be clearly seen. The variable resistance just visible to the left of the coils is R3 and the lettering corresponds with that of Fig. 1.

usually very critical, but the maximum sensitivity is obtained when the valve is only just oscillating. On the other hand, reception of a strong signal necessitates a greater amplitude of oscillation if distortion is to be avoided, and, apart from this, the adjustment of the anode voltage affects the oscillator frequency somewhat, so that the variable resistance can be used as a convenient fine-tuning adjustment. As might be expected, tuning is extremely critical, and a reduction ratio of over 500-1 is necessary. This is readily obtainable with the Igranic Indigraph Micrometer dial, but the closer adjustment obtainable by R3 is very helpful.

**Constructional Details**

The H.F. chokes Ch1 and Ch2 can readily be made by winding about 50 turns of fine wire on a length of 3/4 in. tubing of a length of about one inch. Alternatively, the Eddystone type 947 may be used. In order to prevent the valve oscillating at a frequency determined by the chokes instead of the tuning coils, the 600 ohms resistance R2 is included. The choke Ch3 for the output feed circuit can be of any good quality type suited to the input of the receiver with which the converter is used.

The tuning coils are very simply made. The grid coil L2 consists of six turns of No. 16 tinned copper wire, while the anode coil L3 has five turns; a single turn suffices for the aerial coil L1. The coils are close wound on a 3/4 in. diameter former. When the tension is slackened the diameter increases somewhat and the former can be removed. The turns of the coil can then be pulled apart so that the spac-

ing of the turns is rather less than the wire diameter. The method of mounting will be clear from the illustrations.

It is essential that the framework holding coils, condensers, and valve should be very rigid, for any vibration will make it impossible to hold a signal. In the layout adopted the valve holder is mounted on the left support, although this does not necessarily give the shortest wiring. It has, however, been found to be convenient where different types of valve are used. With a screen-grid valve, for instance, a very short anode lead can be obtained, and as the greatest sensitivity is obtained with this type, it is obviously the case when most advantage is obtained from short wiring.

In general, the receiver should be tuned to its most sensitive frequency, avoiding any setting upon which interference from broadcasting might occur, the lower end of the long waveband usually being best. The condenser C2 should be set at about one complete turn from full capacity. The slider of the potentiometer R1 should be placed at the negative end and R3 at maximum. Start with a tapping on the H.T. battery, usually about 60 volts, just insufficient to cause oscillation, and then reduce R3. If howling occurs when oscillation starts, adjust R1 to such a point that the valve will just slide into oscillation when R3 is reduced without any tendency to howl.

**Operating Notes**

With the Mazda HL2 valve employed in the experiments this condition was easily reached with a standing anode current in the oscillating condition of less than 2 mA. A strong signal requires stronger oscillation if distortion is to be avoided, however, and R3 must then be reduced until the current reads 6 or 8 mA.

Initial testing may offer some difficulties on account of the small number of transmissions on ultra-short wavelengths. It is useful to remember, therefore, that the ignition systems of most cars radiate quite strongly at these high frequencies, and a passing car is usually distinctly audible, and provides a useful, if intermittent, signal for testing purposes.

In cases where the set is to be used in the London area, and is intended chiefly for reception of the experimental transmissions from Crystal Palace and those conducted by the B.B.C., and the E.M.I., a triode oscillator valve is the best. At greater distances, however, a screen-grid valve is to be preferred on account of the higher sensitivity. The circuit remains the same with this type of valve, except for the provision of a screen feed. This should be decoupled by a 5,000 ohms resistance, and a 0.0001  $\mu$ F. by-pass condenser connected between screen and -L.T. A screen potential of 60-80 volts with an anode supply of 100-120 volts is sufficient.

Experiments with this unit have been conducted in the heart of London, and with a three-valve receiver operating a loud speaker. Using a screen-grid frequency changer valve and no aerial the Baird transmissions on 6.25 metres from the Crystal Palace were received at such a strength as to cause an overloading effect in the first valve and serious distortion. It was found necessary, therefore, to change to a triode, for its greater input handling capacity reduced the risk of distortion due to overloading. Television transmissions on a wavelength of about 7.25 metres were also received at a similar strength. At such short ranges an aerial appears to be unnecessary, and this is doubtless accounted for by the large diameter of the coils in relation to the wavelength.

**Available Transmissions**

The unit has been tried with various receivers and with input circuits adjusted to various frequencies between 110 kc/s and 1,500 kc/s with equally good results. Transmissions on these wavelengths are not sufficiently numerous to make 5-metre reception of popular appeal, but it is undoubtedly of great experimental interest. At the present time Baird Television are conducting experimental transmissions from the Crystal Palace on a wavelength of 6.25 metres, and these consist alternately of gramophone records and television. On higher wavelengths both the B.B.C. and the Electrical and Musical Industries are transmitting, and there are numbers of amateurs throughout the country working at various times, so that in most districts

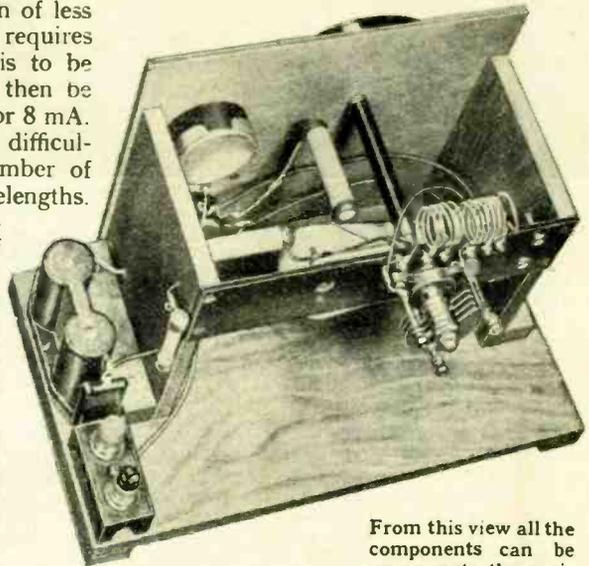

From this view all the components can be seen; note the position of the valve with the two special short-wave H.F. chokes suspended above it.

some station should be easily receivable.

A few remarks about the choice of components may be of interest. The valve-holder should be of the low-loss type and the skeleton model marketed by K.P. Instruments is quite suitable. The semi-variable condenser C2 should be of rigid construction, and a Cyldon model was used in the original converter with an Eddystone 40 mmfd. microdenser, type Picut, for C1.

# NEWS of the WEEK

## Current Events in Brief Review

### For the Critics

FOLLOWING the practice of the B.B.C., the Belgian broadcasting authorities have installed a critics' listening room in Radio House, Brussels.

### More Trouble for Huizen

HUIZEN'S rival, the new 20-kW transmitter at Brasov, Rumania, scheduled to operate on the same wavelength, i.e., 1,875 metres, is, we learn, to start test transmissions on December 1st.

### The Anti-interference War

NEWCASTLE RADIO SOCIETY is seeking permission to send a deputation to the Electricity Board to ask for legislation to be passed prohibiting the supply of electric current to any premises where plant is installed that causes electrical interference to wireless reception.

### Nearing the Sixth Million

THE total number of licences in force at the end of October was 5,768,000, showing a net increase of 47,500 over the figures for the previous month.

### A Silent Show

SILENCE was the rule at the first wireless exhibition at Luxembourg, held from November 12th to the 20th. The Salon was sound-proof and visitors were requested not to converse too loudly so that patrons could judge the quality of the sets being demonstrated.

### "Liquor on the Air"

DESPITE the death of Prohibition, it seems unlikely that American distilleries will be successful in their demands for "time on the air," writes our Wash-

### Wireless on Tap in Holland

HOLLAND now has 613,997 registered listeners, or 74 per thousand of the population. Of this total only 316,956 possess wireless receivers; no fewer than 297,041 subscribe to the wired relay systems.

### A Lucky Listener

A VALUABLE gold watch and Albert chain is to be presented to the 500,000th subscriber to the Austrian broadcasting service. The last reported figure was 495,407, and it is expected that the lucky licensee will put in an appearance within the next few days. The licence figures have jumped considerably since the recent improvements to the Bisamberg station.

### Amateurs and U.S. Navy

IN view of the success achieved with the new Royal Naval Wireless Auxiliary Reserve in this country, it is interesting to note that its "opposite number" in the U.S. was recently addressed by radio from the Washington station by the Secretary of the Navy, the speech being copied by some five hundred radio amateurs all over America.

During the past year the Naval Communication Reservists of the Radio Relay League have taken a very prominent part in emergency working in connection with the California earthquake, the loss of the Akron, the Ohio river flood and recent storms and hurricanes.

### R.S.G.B. Standard Frequency Transmissions

ACCURACY to within 0.01 per cent. is claimed for the new standard frequency transmissions covering the 3.5 kc. band which begin on Sunday next, November 26th, from G6NF, West Norwood, London, S.E.27, under the auspices of the R.S.G.B. These transmissions, which are to be made on the last Sunday of each calendar month, will adhere to the following schedule:—

09.30 .... 3525 kcs (85 metres)  
09.40 .... 3625 kcs (82.75 metres)  
09.50 .... 3725 kcs (80.6 metres)

The call will consist of R.S.G.B. interspersed with ten-second dashes and statement of frequency. An input of 100 watts to the final amplifier should be adequate to cover the British Isles. Reports of reception will be welcomed by the R.S.G.B.

### International Amateur Broadcasts

THE International DX'ers Alliance announces the following transmissions during the coming week. All times shown are G.M.T.:—

Nov. 26.—8.30-9.30 a.m.	CX26.	Montevideo. 585 kc/s. 512 m.
Nov. 27.—6-7 a.m.	XEPN.	Piedras Negros. 600 kc/s. 500 m.
Nov. 27.—8.30-9.30 a.m.	CP4.	La Paz. 6,080 kc/s. 49.3 m.
Nov. 30.—5.30 a.m.	HIX.	Santa Domingo 579 kc/s. 519 m.
Nov. 30.—5.30 a.m.	HIX.	Santa Domingo. 6,000 kc/s. 50 m.

Reports are welcomed by the I.D.A., 1018, North Prairie Street, Bloomington, Illinois, U.S.A.

### Why Witzleben Broke Down

THE mystery of the breakdown of the Berlin-Witzleben transmitter during the great Hitler speech on November 10th is cleared up by the explanation that the engineers were being too careful. It seems that the engineers feared that the switching off of so many factory lights at the beginning of the speech would mean a disturbance on the power line, so they decided to run the Witzleben transmitter off its reserve Diesel engine. Unhappily, the Diesel engine broke down, and it was necessary to switch over to the mains in the middle of the Chancellor's speech. The interruption to listeners was of less than a minute's duration.

### What Next?

A METZ journal is exhibiting in its windows a wireless receiver contained in a fountain pen. This should be an ideal contrivance for radio critics.

### "O.B." Misses Fire

DURING the recent State Lottery Draw before a huge crowd at the Trocadero, Paris, microphones were present for the broadcasting of the impressions of the lucky ones as their tickets were drawn. Unfortunately, no one present drew a prize.

### Disappointed Teachers

LATEST among those endeavouring to dodge the new French radio tax are the schoolmasters, many of whom have suddenly decided to install "school radio sets" in the hope that these would be exempted from tax. But the law states that receivers are only exempted if permanently installed in class-rooms; many teachers have been using their sets "after hours."

### "Ultra-shorts" in the Air

THE recent ultra-short wave 'plane tests in this country are recalled by the news that 5-metre transmissions are now being conducted daily from the weather research 'plane of the Massachusetts Institute of Technology, flying at heights of from 500 feet to nearly four miles above Boston.

The transmissions, which are telephony, give weather information recorded on automatic instruments fastened under the wings of the 'plane. The American Radio Relay League, which considers the investigation to be the most important of its kind ever attempted, has notified all listeners in the U.S. and Canada to listen and report on reception conditions. During the descents each day special broadcasts for the benefit of amateur operators are made at intervals of 500 feet.

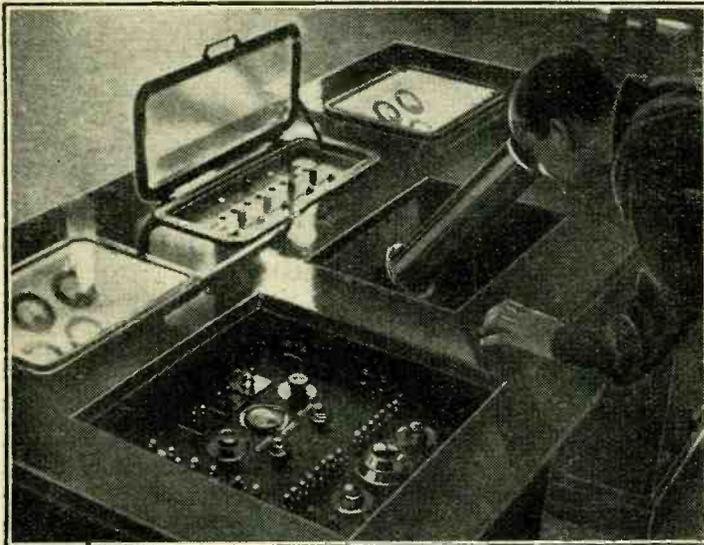

WATCHING THE MODULATION at Lakihegy, near Budapest, where Hungary's new 120-kilowatt is now testing. The engineer is studying the modulation curve in a cathode ray oscillograph.

### The "No Capacity" Condenser

THE first entirely capacity-free variable condenser" was the startling description of a new condenser in the window of a Copenhagen radio dealer, writes our Danish correspondent, and Copenhagen fans agreed that this must be "the real thing" in silent tuning. Actually, the condenser is specially shielded from hand capacity effects.

### Novel Running Commentary

A NOVEL experiment was tried at the recent Copenhagen Traffic Exhibition where visitors gathered before a model of the modern Diesel-engined ferry *Sjaelland*, were able to listen to a description by wireless given by an engineer aboard the actual ferry sailing between Korsor and Nyborg. Spectators were able to put questions to the engineer via the short-wave transmitter at Skamlebaek, the answers being reproduced by a loud speaker.

ington correspondent. Already William S. Paley, president of the Columbia broadcasting system, has announced that his network will not carry any advertising of whisky, gin or other "hard liquors," though no reason is seen for refusing to carry programmes sponsored by beer and wine firms.

It is expected that the National Broadcasting Company will either follow suit or await the "shake-down" of the post-prohibition era before deciding what to do.

### Broadcasting from Egypt

ALL private wireless stations in Egypt are to be suppressed with the opening of the new broadcasting station at Abou Zaabal. The Government representatives on the programme committee will include the sub-director of the Police Department, besides Dr. Aly Pacha, Dean of the Faculty of Medicine, and Mohamed Hassanein, Inspector of Educational Establishments. The station is to be worked by the Marconi Company.

The Wireless World

# FOREIGN PROGRAMME SUPPLEMENT

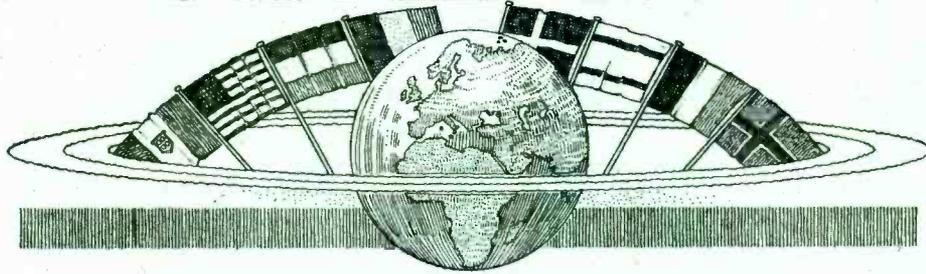

## SUNDAY

### NOVEMBER THE TWENTY-SIXTH

#### ATHLONE

725 kc/s, 413 metres; 60 kW. Relayed by Dublin, 1,382 kc/s, 217 metres; and Cork, 1,337 kc/s, 224.4 metres.—1.0 to 4.0 p.m., Programme by the I.B.C. (Ireland), Ltd. 1.0, Broadcast of Dance Music. Black Rhythm; Can't we meet again?; The Night is gone (Castillo); I cover the Waterfront (Heymann); My Wishing Song (Kahal); Lazybones (Mercer); Pink Elephants (Woods); Sophisticated Lady (Ellington). 1.30, Concert. Dixie Doorway (Parish); I can't forget the Night we met (Clifford); The Whisper Waltz (Burke); Adorable (Whiting). 1.45, Concert of Popular Music. Selection from The Desert Song (Rouberg); Trouble in Paradise (Wever); Song: Less than the Dust, from Indian Love Lyrics (Woodforde-Finden); The Blue Danube (Strauss). 2.0, Concert of Light Music. Ständchen (Heykens); Duet: Indian Love Call from Rose Marie (Friml); The Bumble Bees' Wedding (Clare); Selection from Wonder Bar (Farcas). 2.15, Concert. The Last Round Up (Hill); Waltzing alone with you (Gerald); What have we got to lose? (Kent); I couldn't tell them what to do. 2.30, Concert. Selection from Coppelia (Delibes); Barcarolle from The Tales of Hoffman (Offenbach); Song: Myself when young (Lehmann); Waltz, Liebeslied (Kreisler). 2.45, Accordion Band Music. Overture, Trieste (Pietro); Festival March (Michael); Waltz, Lorentina (arr. Macari); Coal Black Mammy (St. Helier). 3.0, Concert by Tony Reddin and his Radiolians. Sweep; Happy as the Day is long; My Gipsy Rhapsody; Rhythmic Russian Rhapsody; I'll show you off (Don't be late in the Morning); Musical Comedy Selection from New Moon; Cowboy Joe; Letting in the Sunshine; Rock-a-bye Moon; One more Hour of Love; Little Beggar Man; Selection from No, No, Nanette; Let's all be happy together; Sunset Land; Japanese Sandman; Signature Tune: Let's call it a Day. 8.30, Time Signal. 8.31, Concert by the Station Orchestra. 9.0, Relay from Ennis Cathedral. 10.0, Concert by John Stephenson and Company with the Station Orchestra. 10.45, Athletic and Sports Talk. 11.0, Time, News, Weather and Close Down.

#### BARCELONA

EAJ1, 858 kc/s, 349.6 metres; 8 kW.—11.0 a.m., Chimes from the Cathedral and Weather. 1.0 p.m., Gramophone Music. In the interval at 1.30, Theatre Notes. 2.0, Sextet Concert. 3.0, Programme for Hospitals and other Benevolent Institutions. 4.0 to 5.30, Interval. 5.30, Agricultural Talk and Gramophone Music. 6.0, An Opera relayed from the Gran Teatro del Liceo. 9.0, Gramophone Music. 10.45, Chess Lesson. 11.0 (approx.), Close Down.

BASLE.—See Schweizerischer Landessender.

#### BELGRADE

658 kc/s, 429.7 metres; 2.8 kW.—6.0 p.m., Popular Music on Gramophone Records. 6.30, Song Recital by Zica Tomic. 7.0, Talk. 7.30, Military Band Concert. 9.15, Time Signal, Sports Notes and News. 9.30 (approx.), Cigány Music—from the Knez Mihailo Restaurant.

#### BERLIN

DEUTSCHLANDSENDER (R E I C H S-SENDER), 183.5 kc/s, 1,635 metres; 60 kW.—5.15 a.m., Gymnastics. 5.30, To-day's Motto. 5.35, Harbour Concert, from Hamburg. 7.0, Agricultural Programme. 7.55, Chimes from the Potsdam Garrison Church, followed by Divine Service. 9.5, Weather Report. 9.10, Interval. 10.0, Recitation from The German Lord's Prayer (Carl Ludwig Löhe). 10.15, Weather. 10.30, See Leipzig. 11.0, Orchestral Concert, conducted by Karl Schlichting. 11.55, Time Signal. 12 Noon, Concert, from Leipzig. 1.0 p.m., Programme for Children. 2.0, Talk. 2.30, Concert. 4.0, Goetz Otto Stoffregen reads from his own Works. 4.30, Programme in commemoration

of Dead Singers and Orators. 5.30, Death, where is thy Sting?—Readings from German Mystics. 6.30, Memorial Programme, from Potsdam, Choral and Orchestral Music. 7.15, Maria Stuart—A Drama (Schiller). 9.0, News. 9.45, Weather. 10.0, See Langenberg. 11.0 (approx.), Close Down.

#### BERLIN

FUNKSTUNDE, 716 kc/s, 419 metres; 1.5 kW. Relayed by Zeesen, DJC, DJA, DJD, DJB, and DJE.—10.30 a.m., See Leipzig. 11.0, See Hamburg. 1.0 p.m., Interval. 1.30, Radio Report from the Oceanographical Museum. 2.15, Radio Report from the Berlin Cemetery. 2.30, Sports Notes. 3.0, See Heilsberg. 5.0, Gramophone Concert. 5.30, The Human Face—Radio Report on a Collection of Death Masks. 5.50, Das Grosse Totenspiel—Play (Ernst Wiechert), with Music by Werner Egk. 6.50, Sports Notes. 7.0, Lottery Announcements. 7.5, Organ Recital by Karl Linder, with the Berlin Station Orchestra, conducted by Hans von Benda. 7.40, Totenfeier (Oscar Wappenschmitt), by the Berlin Station Choir and Orchestra, conducted by the Composer. 8.5, Sleep, Dreams, and Death—Programme arranged by Ruth Schumann, with Music by Fritz Stühlmacher. 9.0, News. 9.15 (approx.), Gramophone Records of Light Music. In the interval, Music by the Berlin Station Choir. 11.0 (approx.), Close Down.

BERNE.—See Schweizerischer Landessender.

BEROMUNSTER.—See Schweizerischer Landessender.

BODEN.—See Stockholm.

BODO.—See Oslo.

#### BRATISLAVA

1,073 kc/s, 279.5 metres; 14 kW.—6.0 p.m., See Prague. 7.20, See Brno. 8.0, See Prague. 10.0 (approx.), Close Down.

BREMEN.—See Hamburg.

#### BRESLAU

923 kc/s, 325 metres; 60 kW. Relayed by Gleiwitz, 1,185 kc/s, 253.1 metres.—10.30 a.m., See Leipzig. 11.0 (approx.), See Berlin (Deutschlandsender). 1.0 p.m., News. 2.25, Programme for Children. 3.0, Concert by the Station Orchestra, conducted by Ernst Josef Topitz. In an interval from 3.50 to 4.10, Reading. 5.0, Talk with Pianoforte Illustrations: The Glorification of Death in the Dance of Death. 5.30, Programme in Memory of those who fell in the Great War, relayed from the Nikolaikirche, Brieg. 6.0, Sports Notes. 6.20, String Quartet in D Minor (Schubert), on Gramophone Records. 7.0, Die Geschichte einer Mutter (The History of a Mother)—Mystery Play in five Scenes, with Music (Gerhard Ewald Rischka), from a Story by Hans Christian Andersen. 8.0, News. 8.15, Totentanz, 1933 (Peter Steinbach), Music by Ernst August Voelkel. 9.15, Time and News. 9.45, Concert by the Silesian Philharmonic Orchestra, conducted by Gerhard Ewald Rischka. 11.0 (approx.), Close Down.

#### BRNO

878 kc/s, 342 metres; 35 kW.—3.0 p.m., Concert by the Station Orchestra, conducted by Janota. 4.30, Pianoforte Recital by Anna Skalická. 5.0, German Transmission: Song and Pianoforte Recital by Louise Krubl (Songs), Ackermann (Pianoforte), and Beran (Pianoforte). 6.0, See Prague. 7.20,

Slovak Folk Song Recital. 8.0, See Prague. 10.0 (approx.), Close Down.

#### BRUSSELS (No. 1)

1.N.R., 589 kc/s, 509.2 metres; 15 kW.—9.45 a.m., Cookery Hints and Miscellaneous Announcements. 10.0, Gramophone Concert. 11.0, Concert by the Small Station Orchestra, conducted by Pierre Leemans. 12 Noon, Concert by the Station Symphony Orchestra, conducted by Jean Knips. Soloist: Robert Van Aert (Baritone). 1.0 p.m., Le Journal Parlé. 1.10, Concert by the Radio Orchestra, conducted by Charles Walpot. Soloist, Mme. Rambert (Songs). 1.30, Monologues by Emile Deluc. 1.40, Delibes Potpourri (Urbach). 1.50, Radio Report of the Football Match, Belgium v. Denmark, relayed from the Heysel Stadium. 5.0, Dance Music, relayed from the St. Sauveur Palais de Danse. 5.30 (approx.), Football Match Results. 6.15, Gramophone Music. 6.45, La lune de miel—Sketch (Desiré Grevesse). 7.0, Gramophone Music. 7.15, Religious Address. 7.30, Talk on Music. 8.0, Concert by the Station Symphony Orchestra, Soloist: Vera Pridova (Kumps). 8.30, La défense du bonheur—One-Act Play in Verse (Georges Garin). 9.0, Orchestral Concert (cont'd.). 10.0, Le Journal Parlé. 10.10, Concert by Robert de Kers and his Cabaret Kings, relayed from the Century Hotel, Antwerp.

#### BRUSSELS (No. 2)

N.I.R., 888 kc/s, 337.8 metres; 15 kW.—Programme in Flemish.—10.0 a.m., Orchestral Concert, conducted by Pierre Leemans. Soloist: Douliex (Pianoforte). 11.0, Gramophone Music. 12 Noon, Concert by the Radio Orchestra, conducted by Walpot. Soloist: Mme. Rambert (Songs). 1.0 p.m., Le Journal Parlé. 1.10, Concert by the Symphony Orchestra, conducted by Jean Knips. Soloists: Van Aert (Baritone), and Piette (Clarinet). 2.0, Running Commentary on the Football Match, Belgium v. Denmark. 5.0, Concert by the Radio Orchestra, conducted by Charles Walpot. In the interval at 5.30 (approx.), Sports Results. 6.0, Pictures from an Exhibition (Mussorgsky), on Gramophone Records. 6.30, Concert by the Small Station Orchestra, conducted by Pierre Leemans. 7.15, Religious Address. 7.30, Le Journal Parlé. 7.55, Music Review. 8.0, Sissy—Operetta (Kreisler), relayed from the Royal Flemish Opera House, Antwerp. In the intervals, Humorous Programme by Remes and Le Journal Parlé.

#### BUCHAREST

761 kc/s, 394 metres; 12 kW.—4.0 p.m., Concert of Variety Music by the Marco Orchestra. In the interval at 5.0, Radio Journal. 6.0, Educational Talk. 6.20, Gramophone Music. 6.45, Talk. 7.0, Operetta Programme. In the intervals, Radio Journal.

#### BUDAPEST

545 kc/s, 550.5 metres; 18.5 kW.—Also relayed on 840 metres from 6.20 p.m. till Close Down.—11.20 a.m., Weather and Tides Report. 11.25, Concert by the Opera House Orchestra, conducted by Zoltan Sany. Radio Chronicle in the interval. 1.0 p.m., Gramophone Music. 2.0, Agricultural Talk. 2.45, Military Band Concert. 3.30, Talk on Petöfi. 4.30, Talk. 5.0, Concert with Popular Songs and Hungarian Melodies from the Café Ostende. 6.20, Variety Items. 6.50, Pianoforte Recital. 7.30, Sports and Racing Results. 7.50, A Comedy (Eugène Labiche). 8.35, Concert by the Inre Magyar Cigány Orchestra, relayed from the Hotel Hun-

garia. 9.45, Trio Concert from the Café Simphon.

CASSEL.—See Frankfurt.

#### COPENHAGEN

1,067 kc/s, 281 metres; 0.75 kW. Relayed by Kalundborg, 260 kc/s, 1,153.8 metres; and Skamlebaek OXY, 49.4 metres. 11.0, Time Signal and Chimes from the Town Hall. 11.2, Concert by Louis Preil's Instrumental Ensemble. 12 Noon, Talk in English: The Grand Tour of Scotland. 12.20 p.m., Talk in German: Discussion on Munich, Leipzig and other German Towns. 12.40, Reading in French: La chatte (Colette). 1.0, Divine Service, relayed from Holmens Kirke. 2.25, Concert by the Radio Symphony Orchestra, relayed from Odd Fellows Hall. Conductor: Fritz Busch. Soloists: Tenna Frederiksen Kraft and Niels Hansen (Songs). 4.20, Programme for Children. 4.50, Gramophone Concert of Light Music. 5.20, Talk: The Position of Science in Germany To-day. 5.50, Weather. 6.0, News. 6.15, Time Signal. 6.30, Talk: The History of English Agriculture from 1850 till the Outbreak of the Great War. 7.0, Time Signal from the Town Hall. 7.1, The Hansen Family—Humorous Episode (Jens Locher). 7.15, Concert of Folk Songs of the Nations by a Male Voice Choir, conducted by Wilhelm Rosenberg. In the interval, Reading of Folk Stories (Axel Ohrik). 8.20, Pianoforte Sonata, No. 3, in B Flat (Mozart), played by Folmer Jensen. 8.40, Gramophone Records of Caruso. 8.55, News. 9.5, Readings. 9.15, Concert of Swedish and Finnish Music by the Radio Orchestra, conducted by Emil Reesen. 10.0, Dance Music, relayed from the Wivex Restaurant. In an interval at 11.0, Time Signal and Chimes from the Town Hall. 11.30 (approx.), Close Down.

CORK.—See Athlone.

DANZIG.—See Heilsberg.

DRESDEN.—See Leipzig.

#### FECAMP

1,328 kc/s, 225.9 metres; 10 kW.—8.45 a.m. to 12 Noon, Programme in English by the I.B.C. 8.45, Orchestral Music. The Skaters' Waltz (Waldteufel); Spanish Gipsy Dance (Marqua); Xylophone Solo: Snappy Sticks (Robbins); The Busy Bee (Bendix); Columbine (Garland); The Wedding of the Rose (Jessell); Pianoforte Solo: That Futuristic Rag (Bloom); Poor Butterfly (de Philippi); Waltzes from A Waltz Dream (O. Straus); Violin Solo: Chanson bohémienne (Boldi); Selection from The Merry Widow (Lehar). 9.30, Military Music. 1812 Overture (Tchaikovsky); Jolly Fellows (Vollsteit); Xylophone Solo: National Emblem March (Dagley); Berceuse (Lacôme); Prælude (Jarnefeld); Amoretantanz (Gungl); March, Washington Post (Souza). 10.0, Dance Music. Signature Tune, The Bells of Normandy; A One-Horse Town; Pettin' in the Park; Elvira; The Gold Diggers' Song; My Lucky Day; For Love Time; For you, just you my Baby; Gooftus; How could we be wrong; There's a Cabin in the Pines; Dawn in Montmartre; The Wedding of Mr. Mickey Mouse; It's the Talk of the Town; Tick, Tock: Oh! Johanna!; Shadows on the Swanee; Gramophone Tune. 11.0, Happy Hour. Part I: Orchestral Concert. Signature Tune: Ballet égyptien (Luigini); Love and Life in Vienna (Renard); Ay, Ay, Ay (Freire); Selection from The Chocolate Soldier (O. Straus); Smilin' Through (Penn); You're the One; I Love to see the Evening Sun go Down; Lady of Spain; My Mom; Whistle. Part II: Organ Recital. Weymouth Chimes (Howgill); Serenade (Drigo); Roses of Picardy (Haydn Wood); Song: Tired Hands (Sanderson); The Temple Bells (Woodforde-Finden); Waltz and Selection (arr. Stoddon); Signature Tune. 12 Noon, French Programme 2.0 to 7.30 p.m., Programme in English by the I.B.C. 2.0, Concert. Persian March (Friml); Little Girl; Pianoforte Medley: Colledge Humour (Coslow); Sizzietta (von Blon); Fairy Tale (Heykens); Violin Solo: Indian

NOV. 26th

**SUNDAY** continued

Love Call, from Rose Marie (Ermi); Pardon me, Pretty Baby; Waltz, Tales of the Vienna Woods (Joh. Strauss); 2.30, Orchestral Concert; Waltz from The Gipsy Princess (Kálmán); Si petite (Claret); Violin Solo: The Pibroch (Goulesco); Liebesleid (Kreisler); Venetian Boatman's Song (Mantovani); Song: Lay your head on my shoulder (Conrad); La Paloma (Vradier); Selection from The Arabian Nights (Joh. Strauss); 3.0, Gramophone Concert. Destiny Waltz (Baynes); Unrequited Love (Lincke); Wild de Moon, Moon (Cook); Shuffle off to Buffalo (Dubin); Pianoforte Solo: Balloons (Magine); Good-night, but not Goodbye (Roberts); The Song of the Rose (McCulloch); Veterans of Variety; 3.30, Music by an Accordion Band, C'est vous (Künneke); Dinnah (Lewis); Tango Serenade (Stolz); Accordion: Jolly Wango; Marietta (Charlier); Emilienne (Alexander); Signorina (Brown); The Valse of the Gigolo (Alexander); 4.0, Light Orchestral Music; The Coon among the Chickens (Ives); Little Yvonne (Schwartz); Moonbeam (Peter); Lazy Pete (Werner); 4.15, I.B.C. Nursery Corner. Birthday Greetings; 5.0, I.B.C. Members' Request Half-hour. Swanee (Gershwin); Black Eyes (Ferraris); Father O' Flynn (Traditional); The Mill in the Forest (Eilenberg); Goodbye (Tosti); One Fine Day, from Madame Butterfly (Puccini); Tell me To-night (Eyton); The Grasshopper's Dance (Bucalossi); 5.30, Orchestral Concert. Pas des Fleurs, from Nuits (Delibes); Anitra's Dance (Grieg); Harlequin's Serenade (Leoncavallo); Scherzo from A Midsummer Night's Dream (Mendelssohn); 5.45, Concert. With you here and me here (Eyton); Hebbie Hebbies (Atkins); Louisville Lady (Hill); Hold your Man (Freed); 6.0, Concert. March. Light of Foot (Latam); A Little Idea of my own; Trouble in Paradise (Wever); Selection from The Pirates of Penzance (Sullivan); Widdicombe Fair (arr. Jacob); It's not a Secret any more (Blane); It's Sunday down in Caroline (Synes); The parade of the Tin Soldiers; 6.30, Concert. Hiawatha's Lullaby; Mood Indigo; I cover the Waterfront (Heymann); Many Happy Returns (de Bear); Selection from White Horse Inn (Stolz-Benatzky); Nightfall; Heading for the Last Round Up (Hill); Fiddler Joe; 7.0, Military Music. Old Panama (Aford); Valse des alouettes (Drigo); Bells of Somerset; Hobomoko (Heeves); Ballet Music from La Source (Delibes); Naval Patrol (Williams); Glow-Worm Idyll (Lincke); Valse Triste (Sibelius); 7.30, French Programme; 9.0 till Close Down. Programme in English by the I.B.C. 9.0, Dance Music. Signature Tune: Happy Feet; A Couple of Pals; A Couple of Fools in love; For Love Time; Throw open wide your Window, Dear; Smoke Rings; La Cumparsita; Trouble in Paradise; Experiment; Signature Tune: Happy Feet; 9.30, Talkie Time. Tunes from the Talkies and Shows. Signature Tune: Sittin' in the Dark; Dance Pretty Lady (Strauss); Selection from This Week of Grace (Parr-Davies); Johnny (Hollander); Thanks (Coslow); A Girl like Nina (Abraham); Selection from I est charmant (Moretti); Cuban Love Song (Fields); A Glass of Golden Bubbles (Strauss); Signature Tune; 10.0, Orchestral Concert. Morning, Noon and Night (Suppé); Violin Solo: Moment musical (Schubert); El Relicario (Padilla); Kisses in the Dark (de Micheli); Humoresque (Dvorák); In the Valley of the Poppies (Ancliff); Violin Solo: An Old Viennese Dance (Voglein); Gridiron Club March (Souza); 10.30, Dance Music. Dear Stranger; Love in the Moonlight; I only want one Girl; Symphony of the Breeze; Who's afraid of the Big Bad Wolf; The Three Trees; After you; The Cage in the Window; The Last round up; 11.0, Light Music. Veleta Medley (Varney); Stephanie Gavotte (Zibulka); Your Song of Paradise; The Clatter of the Clogs (Flynn); Banjo Quartet: Snatches of Song (arr. Grimshaw); The Ghost Walk; Ginger Snaps (Bourdon); 11.30, Concert arranged by the International Broadcasting Company (Ireland), Ltd. Signature Tune: Come back to Erin; Fantasia on the Melodies of Johann Strauss; Woodland Peace (Pavilla); Irish National March (Bease); Song: My Mother's Garden (Inflany); Play of Butterflies (Heykens); In far away Donegal (Alexander); I kiss your Lips (Rudolphe); March. La Czarine (Gänne); Signature Tune: Come back to Erin; 12.5 a.m. (Monday), I.B.C. Late News Bulletin in English; 12.10 (approx.), I.B.C. Club Concert for Built Listeners. Signature Tune: The Chum Song; Everyone loves my Marguerite (Woods); Sentimental Gentleman from Georgia (Perkins); Snowball (Carmichael); Mary Rose (Parr-Davies); Rooky Road (Gibbs); Morning, Noon and Night (Swaenstrom); Don't blame me (Fields); My Moonlight Madonna (Fibich); Louisville Lady (Hill); 'Twixt the Devil and the Deep Blue Sea (Eyton); It's not a secret any more (Blue); I bring a Song (Young); With you here and me here (Eyton); Signature Tune; 1.0, Gramophone Concert. Sweet Sue, just you (Young); Just an Echo in the Valley (Woods); You did everything for me (Connelly); Tony's Wife (Adamson); Song: Mountain Lovers (Squires); Marching through Georgia; Cornflowers and Poppies (Waldteufel); Selection from The Yeoman of the Guard (Sullivan); 1.30, Music by a Hawaiian Band. Aloha Oe (Lilioukalanii); Tomi Tomi (Traditional); Naughty Hawaii (Carlo); Honolulu Bay

(Kahu); My Waikiki Mermaid (Traditional); Hula Hula; Cara Mia (Brodzsky); Isle of Paradise (Earl); 2.0, I.B.C. Good-night Melody and Close Down.

**FLENSBURG.**—See Hamburg.

**FLORENCE.**—See Turin.

**FRANKFURT**

1,157 kc/s, 259.3 metres; 17 kW. Relayed by Cassel and Trier, 1,157 kc/s, 259.3 metres.—10.30 a.m., See Leipzig. 11.0, See Langenberg. 12 Noon, See Stuttgart. 12.15 p.m., Extracts from the Requiem (Verdi) by the Soloists, choir, and Orchestra of the Scala, Milan (on Gramophone Records). 1.20, Talks arranged by the Wiesbaden Board of Agriculture. 1.30, Rural Programme. 2.0, See Langenberg. 3.0, See Stuttgart. 5.0, Reading from the Works of Ludwig Hebbel. 5.25, The Fate of Lieutenant Nolan—after the Dramatic Ballad by Heinrich Stilling. 5.45, Talk: Remembrance Day. 6.15, Gramophone Concert. 6.40, Talk. 7.0, See Stuttgart. 7.15, See Berlin (Deutschlandsender). 8.10, See Stuttgart. 9.0, Time and News. 9.20, See Stuttgart. 9.30, Local News and Weather. 9.40, See Langenberg. 11.0, Serenade. 1.0 a.m. (Monday), Close Down.

**FREDRIKSSTAD.**—See Oslo.

**FREIBURG.**—See Stuttgart.

**GENEVA.**—See Radio-Suisse Romande.

**GENOA.**—See Turin.

**GLEIWITZ.**—See Breslau.

**GÖTEBORG.**—See Stockholm.

**GRAZ.**—See Vienna.

**HAMAR.**—See Oslo.

**HAMBURG**

806 kc/s, 372 metres; 1.5 kW. Relayed by Bremen, 1,112 kc/s, 269.8 metres; Flensburg and Hanover, 1,319 kc/s, 227.4 metres; and Kiel, 1,292 kc/s, 232.2 metres.—11.0 a.m., Choral and Orchestral Concert with Soloists. In the interval at 11.55, Time and Weather. 1.0 p.m., Snow White—Fairly Play for Children. 2.0, Programme in commemoration of the Dead, with the collaboration of the String Quartet and Gerhard Gregor (Organ). 3.0, See Heilsberg. 4.50, Talk: At the Graves of North German Writers. 5.15, Requiem—Violin, Organ and Choral Recital in commemoration of the Dead. 6.20 (from Hanover). In memoriam—Programme by the Station Orchestra, conducted by Otto Ebel von Sosen, with Recitations and Commentary. 6.50, Weather. 7.0, Gevatte Tod—A Play (Eberhard König), with incidental Music. 8.30, Songs of Death (Joh. Seb. Bach) sung by Eva Schlee and Imradg Eitzdorf. 8.40, Ciacone in D Minor (Bach-Busoni). 9.0, Time and News. 9.30 Concert.

**HANOVER.**—See Hamburg.

**HEILSBURG**

1,085 kc/s, 276.5 metres; 60 kW. Relayed by Danzig, 671 kc/s, 447.1 metres.—10.30 a.m., See Leipzig. 11.30 a.m. (approx.), Concert by the Königsberg Opera House Orchestra, conducted by Wolfgang Brückner. In the interval at 12 Noon, Talk: The German War-Graves Commission. 1.30, Talk on Chess. 2.0, Violin, 'Cello, and Harp Recital. 2.30, Programme by the Hitler Jugend. 3.0 (from Danzig). Concert conducted by Ernst Stieberitz. In the interval at 4.0, Sports Notes. 5.0, Stories and Legends for Remembrance Day, in North German Dialect. 5.30, There is a Reaper—Choral Concert of Sacred and Secular Music. 6.0 to 6.15, Interval. 6.15, The Song of the Unknown Soldier (Ernst Schulz-Alexander). 6.45, Sports Notes. 7.0, Iphigenia in Aulis—Opera in Three Acts (Gluck). In the intervals at 7.40 and 8.55, News. 9.25, News and Sports Notes.

**HILVERSUM**

1,013 kc/s, 296.1 metres; 7 kW. up to 5.40 p.m., and 20 kW. from 5.40 p.m.—10.10 to 11.40 a.m., Programme of the Liberal Protestant Radio Society (V.P.R.O.): Divine Service from a Church at Utrecht. 11.40 to 12.40 p.m., Programme of the General Broadcasting Society (A.V.R.O.). 11.40, Time Signal. 11.41, Talk: The Picture of the Week. 12.10 p.m., Concert of Light Music, conducted by Otto Hendriks. 1.40, Weekly Book Talk. 2.10, Concert by the Wireless Orchestra, conducted by Nico Gerlartz. Soloist: Pierre Palla (Pianoforte). Symphonic Poem, Les Préludes (Liszt); Pianoforte Concerto in E flat (Liszt); Grand galop chromatique (Liszt); Gramophone Music; The New World Symphony (Dvorák). 3.55, Gramophone Concert. 4.25, Sports Notes and Gramophone Music. 4.40 to 7.40, Programme of the Workers' Radio Society (V.A.R.A.). 4.40, Programme for Children. 5.40, Concert by the V.A.R.A. Orchestra, conducted by de Groot. 6.40, Talk, followed by Gramophone Music. 7.10, Concert of Light Music. 7.40 till Close Down. Programme of the A.V.R.O. 7.40, Time and News. 7.55, Concert of Light Music by Kovacs Lajos and his Orchestra. 8.40, Song Recital by Tino Pattiera. 8.55, Concert by the Wireless Orchestra, conducted by Albert van Raalte. Soloists: Eva

Bandrowska (Soprano) and Tino Pattiera (Tenor). 9.25, Song Recital by Alex de Haas. 9.45, Concert (cont'd.). 10.25, Gramophone Music. 11.40 (approx.), Close Down.

**HORBY.**—See Stockholm.

**HUIZEN**

160 kc/s, 1,875 metres; 7 kW. until 3.40 p.m. Transmitted from Kootwijk on 50 kW. from 3.40 p.m.—8.10 to 9.10 a.m., Programme of the Christian Radio Society (N.C.R.V.). 8.10, Divine Service. 9.10 to 4.40 p.m., Programme of the Catholic Radio Society (K.R.O.). 9.10, Gramophone Music. 9.46, Pontifical High Mass, relayed from The Dominican Church in Amsterdam. 11.40, Concert by the K.R.O. Sextet. 12.40 p.m., Literary Talk. 1.0, Sextet Concert (cont'd.). 1.40, Religious Address. 2.10, Concert by the Small K.R.O. Orchestra, conducted by van 't Woud. 2.40, Talk: The Third International Missionary Congress. 3.10, Gramophone Music. 3.40, Concert (cont'd.). 4.10, Programme for Invalids. 4.40 to 7.25, N.C.R.V. Programme. 4.40, Divine Service, relayed from a Church in Feyenoord. 7.10, Sacred Music on Gramophone Records. 7.25 till Close Down, K.R.O. Programme. 7.25, Football Results. 7.30, Talk. 7.55, Concert by the K.R.O. Orchestra, conducted by Gerritsen. Soloist: Renée Chemet (Violin). 8.40, News. 8.45, De geheimen zender (The Secret Transmitter)—Radio Play (Mlle. Heijermans). 9.30, Violin and Pianoforte Recital: German Dance (Mozart); Rondo in G (Mozart); Selection from La vida breve (Falla). 9.45, Gramophone Records. 10.0, Orchestral Concert (cont'd.). Selection from Fedora (Giordano); Extracts from Aida (Verdi). 10.20, Choral Epilogue. 10.40 (approx.), Close Down.

**INNSBRUCK.**—See Vienna.

**JUAN LES PINS**

NICE, 1,205 kc/s, 249 metres; 0.8 kW.—8.0 p.m., Sports Notes and Amusement Guide. 8.15, Concert. 9.0 (in the interval), News. 10.0, Request Half-hour. 10.30 till Close Down, Programme in English by the I.B.C. 10.30, Military Band Concert: Old Comrades (Teike); Medley of British Songs (Krier); The Parade of the Tin Soldiers (Jessel); A Merry Hunting Day (Partridge); Wood Nymphs (Coates); El Albanico (Javaloyes); Gaiety Echoes. 11.0, Variety Concert: Orchestra: The Wedding of the Rose (Jessel); Two Sketches: (a) Breakfast Time, (b) Midnight; Pianoforte and Organ Duet, Marigold (Mayerl); Song, The Song of Songs (Moya); Xylophone Solo, The Skaters' Waltz (Waldteufel); The Laughing Sousephane (Grey); Orchestra: Jollity on the Mountains (Petras). 11.30, Light Orchestral Concert: Lazy Pete (Kernsten); Serenade (Schubert); Selection from Mother of Pearl (arr. Fink); Wedding Waltz (Lincke); Hungarian Melodies (Korbay); Dreams of the Ocean (Gungl); Irish Washerwoman (arr. Soerby); Musical Comedy Switch (arr. Hall). 12 Midnight, Dance Music: Hold Me; Waltzing in a Dream; Isn't it Romantic; Standing on the Corner; One little Word led to another; In the Valley of the Moon; Moon Song; Maybe I love you too much; The Old Spinning Wheel; I can't remember; Love will find a way; How do you do, Mr. Brown? My Darling; Sittin' in the Dark; My Heart's to let; Pickaninies' Heaven. 1.0 a.m. (Monday), I.B.C. Goodnight Melody and Close Down.

**KALUNDBORG.**—See Copenhagen.

**KIEL.**—See Hamburg.

**KLAGENFURT.**—See Vienna.

**KOSICE.**—See Prague.

**LANGENBERG**

635 kc/s, 473 metres; 60 kW.—10.0 a.m., Symphony in B flat (Bruckner), by the Station Orchestra, conducted by Buschhöfner. 11.0, Gramophone Concert of Organ and Choral Music. In the interval, Totentanz (Dance of Death)—A Cycle of German Ballads. 12 Noon, See Stuttgart. 12.15 p.m., Vocal and Instrumental Concert. 1.15 to 1.30, Agricultural Programme. 1.40, Talk for Parents and Children: Wise Presents. 2.0, Fairy Tales for Children. 3.0, See Heilsberg. 5.0, Reading from the Letters of Johann Sebastian Bach. 5.15, The Clock Symphony in D. No. 4 (Haydn), on Gramophone Records. 5.45, Bunte Stunde, with Talk by Dr. Förster. Curator of the Wallraf-Richartz Museum, Cologne. 6.45, Sports Notes. 7.0, See Stuttgart. 7.10, See Berlin (Deutschlandsender). 8.10, See Stuttgart. 9.0, See Frankfurt. 9.20, See Stuttgart. 9.30, News, Weather and Sports Notes. 9.40, Light Music. 10.0, Concert by the Station Orchestra, conducted by Buschhöfner. 11.0, See Frankfurt. 1.0 a.m. (Monday), Close Down.

**LAUSANNE.**—See Radio-Suisse Romande.

**LEIPZIG**

770 kc/s, 389.0 metres; 120 kW. Relayed by Dresden, 941 kc/s, 319 metres.—10.30 a.m., Ich hatte viel Bekümmernis—Cantata (Bach), by the Municipal and Gewandhaus

Orchestra, the Choir of St. Thomas' and Soloists. 11.0, Concert by the Leipzig Symphony Orchestra, conducted by Hilmar Weber. Soloist: Alfred Jehmlich (Viola). 1.0 p.m., Weather and Time. 1.5, Programme Announcements. 1.25, Agricultural Notes. 1.35, Children and Animals before the Microphone. 2.10, Recital by Dorothea Brauns. 3.0, Concert by the Dresden Philharmonic Orchestra, relayed from the Dresden Radio Exhibition. 4.0, Announcements of Solutions and Awards in the Competition: Do you know your own Country? 4.15, Talk: Naumburg Cathedral. 4.45, Letters of Men who Fell in the Great War. 5.0, Organ Recital. 5.35, Mozart's Last Days—Radio Play, arranged from Karl Söhle's Play by Dr. Amadeus Grolmann. 6.50, A Sacred Dialogue for Contralto, Mixed Choir and Four Clarinets (Helmut Meyer). 7.35, Concert by the Leipzig Symphony Orchestra, conducted by Hans Weisbach. 9.0, News and Close Down.

**LINZ.**—See Vienna.

**LUXEMBOURG**

252 kc/s, 1,191 metres; 200 kW.—12 Noon, Concert by the Radio Orchestra, conducted by Henri Pensis. 1.0 p.m., Gramophone Music. 7.0 till Close Down, English Evening. 7.0, Symphony Music on Gramophone Records: Petroushka (Stravinsky); The Planets (Holst); Suite, Scenes of Alsace (Granville Bantock); In the Mystic Land of Egypt (Kettelby); Dreaming (Haydn-Wood); The Cress (Byford). 8.50, News in French. 9.0, Pianoforte Recital by Madeleine Beicht: Toccata and Fugue in D minor (Bach-Tausig); Ballad in G minor (Chopin); Etude en forme de valse (Saint-Saëns). 9.30, Concert by the Radio Orchestra, conducted by Henri Pensis: Waltz, Gold and Silver (Lehar); Baby plays Soldiers (Micheli); Hungarian Rhapsody No. 2 (Liszt). 9.50, News in German. 10.0, Gramophone Music: Stephen Foster Melodies; Songs from The Chocolate Soldier (O. Straus); My Blue Heaven (Whiting and Donaldson). 10.15, Dance Music.

**MADRID**

ARANJUEZ, EAQ, 10,000 kc/s, 30 metres; 20 kW.—10.30 p.m., Programme relayed from Madrid (EAJ7). 12 Midnight till Close Down, Concert arranged by the International Broadcasting Company (Ireland), Ltd.: Signature Tune, Come Back to Erin; Yes, Mr. Brown (Abraham); Arrogancia Andaluza (Bruguera); A Song, a Kiss, a Girl (Gilbert); On a Little Street in Honolulu (Sherman); Blues I love to Sing (Ellington); A Penny for Your Thoughts (Cuevas); Kissing is no sin (Eysler); The Love Lieutenant (Gilbert); Signature Tune, Come Back to Erin. 12.30 a.m. (Monday), I.B.C. Good-night Melody and Close Down.

**MADRID**

EAJ7, 707 kc/s, 424.3 metres; 2 kW.—8.0 to 9.0 a.m., Topical Review. 11.30, Municipal Band Concert, relayed from the Retiro. 2.0 p.m., Chimes, Time, Theatre Notes, and Popular Music. 4.0 to 7.0, Interval. 7.0, Chimes. Announcements, and Dance Music. 8.30 to 9.30, Interval. 9.30, Chimes and Time. 9.35 (approx.), Pianoforte Recital by Enriquez Garreta, followed by Song Recital by Palmiro Matamoros del Val (Tenor), in connection with the Music Competition. In the interval, Talk by Gomez de la Serna. 12 Midnight, Chimes. 1.0 a.m. (Monday) till Close Down, I.B.C. Programme of Dance Music: It's Sunday down in Caroline; We belong together; My Gipsy Rhapsody; There's Magic in the Air; Headin' for a Weddin'; Don't blame me; Stay out of my Dreams; Hurricane Harry; What did I do to be so Black and Blue? It's time to sing sweet Adeline again; With you here and me here; You're charming; Sweet Savannah Sue; Swanee; Let's try again; Stay on the Right side of the Road. 2.0, I.B.C. Good-night Melody and Close Down.

**MALMO.**—See Stockholm.

**MILAN.**—See Turin.

**MORAVSKA-OSTRAVA**

1,137 kc/s, 263.8 metres; 11 kW.—11.15 a.m., Concert by the Station Orchestra, conducted by Plichta. 12.30 to 12.55, See Prague. 3.0, See Brno. 4.30, See Prague. 7.20, Dance Music by the Station Orchestra. 8.0, See Prague. 10.0 (approx.), Close Down.

**MOTALA.**—See Stockholm.

**MUHLACKER.**—See Stuttgart.

**MUNICH**

563 kc/s, 533 metres; 1.5 kW. Relayed by Augsburg and Kaiserslautern, 536 kc/s, 560 metres; and Nürnberg, 1,256 kc/s, 239 metres.—10.30 a.m., See Leipzig. 11.0, Concert from the Feldherrnhalle. 12 Noon, Time, Weather and Programme Announcements. 12.10 p.m., Talk: The German Peasant and his Ancestry. 12.30, Gramophone Concert of Popular Music. 1.0 (from Nürnberg), Advanced Chess Lesson. 1.30, Radio Report from the Dabling Race Course. 2.0, Zither Recital. 2.30, Programme for Children. 3.0, Concert by the Small Station Orchestra, conducted by Karl List. 4.25, Tales and Songs of the Bavarian Forests and the Egerland, by the Station Chamber Choir, and Soloists. 4.45, Pianoforte Sonata in C—the Waldstein (Beethoven). 5.5, Talk: In a Motor through the

NOV. 26th

**SUNDAY**

continued

Desert. 5.30, Wind Instrument Concert, relayed from London. 6.30, Reading: A Terrifying Journey in a Balloon. 6.50, Weather and Sports Notes. 7.5, Concert by the Station Orchestra, conducted by Hans Winter. Soloists: Willy Stuhlkauth and Adolf Bruno Winkler (Violin), and Richard Staab (Pianoforte); Overture, Jessonda (Spohr). 9.0, Time, Weather and News. 10.0, See Langenberg.

NAPLES.—See Rome.

NOTODDEN.—See Oslo.

**OSLO**

277 kc/s, 1,063 metres; 60 kW. Relayed by Fredrikstad, 815 kc/s, 368.1 metres; Hamar, 522 kc/s, 574.7 metres; Notodden, 671 kc/s, 447.1 metres; Porsgrund, 662 kc/s, 453.1 metres; and Rjukan, 671 kc/s, 447.1 metres; and Jeløy, LGL, 6,990 kc/s, 42.92 metres.—9.15 a.m., News and Weather. 9.20, Chimes 9.30, Divine Service Relay. 12 Noon (from Fredrikstad), Orchestral Concert. 4.0, p.m., Gramophone Concert. 4.45, Talk. 5.15, Recital of Künnecke Operetta Music arranged for Two Pianofortes. 5.45, Literary Review. 6.15, Weather and News. 6.30, Pianoforte Recital by Waldemar Alme. Five Pieces (Chopin). 7.0, Time Signal. 7.1, Recitations. 7.30, Concert by the Station Orchestra, conducted by Kramm. 8.40, Weather and News. 9.0, Topical Talk. 9.15, Old Dance Music. 9.45, Dance Music on Gramophone Records. 11.0 (approx.), Close Down.

OSTERSUND.—See Stockholm.

**PALERMO**

556 kc/s, 539.5 metres; 3 kW.—9.25 a.m., Bible Reading. 9.40, Sacred Music. 11.5, Agricultural Talk. 11.45, Giornale Radio. 12 Noon till 1.0 p.m., Jazz Music. In an interval at 12.30, Time, Announcements and Weather. 4.30 to 5.30, Gramophone Music. 7.0, Dopolavoro. Notes and Giornale Radio. 7.20, Spjorta Notes. 7.30, Time and Announcements. 7.45, Concert of Opera Music conducted by Fortunio Russo. In the interval, Talk and Announcements. 10.0, Giornale Radio.

**PARIS**

EIFFEL TOWER, Call FLE, 207.5 kc/s, 1,445.7 metres; 18 kW. Time Signals (on 2,650 metres) at 9.25 a.m. and 10.25 p.m. (Preliminary and 6-dot Signals).—12.30 p.m., Concert by the Jean Ibos Orchestra. 1.0, News and Press Review. 1.15, Concert (contd.). 3.15 (approx.), Concert Relay. 5.45, Le Journal Parlé. 7.15, Weather and News. 7.30, Gramophone Concert. 9.0 (approx.), Close Down.

**PARIS**

POSTE PARISIEN; 914 kc/s, 328.2 metres 60 kW.—10.0 a.m., Gramophone Music. 10.5, Recitations. 10.10, Press Review. 10.30, Gramophone Records. 11.0, Gramophone Music. 11.30, Sponsored Concert. 12 Noon, Gramophone Music. 12.15 p.m., Sponsored Concert of Music from Sound Films. 12.45, Sponsored Programme. 12.50, Half an Hour of Fantasy, by Paul Weil. 1.30, Sponsored Gramophone Concert. 2.0, Interval. 7.0, Le Journal Parlé. 7.5, Gramophone Records of Paderevsky. 7.20, Sports Notes. 7.30, Catholic Review. 8.0, Gramophone Records of Chaliapine. 8.30, La morale d'Esculapine—One-Act Play (Henri Francais). 9.0, Interval. 9.20, Guessing Competition: Who is it? 9.35, Concert. 10.30, News.

**PARIS**

RADIO PARIS, Call CFR, 174 kc/s, 1,725 metres; 75 kW.—7.45 a.m. Gramophone Records. Selection from Le Million (Moretti); Donne-moi ton coeur (Rosen); Margaritas (Penalzoza); and Miss Columbia (Marceau). 8.0, Press Review and Weather. 8.30, Gymnastics. 9.20, Advanced English Lesson. 9.40, Elementary English Lesson. 10.0, Elementary Book-keeping Lessons. 10.40, Spanish Lesson. 12 Noon, Religious Address. 12.20 p.m., Sacred Music. Fugue in E minor (Bach); Ave Maria (Arcadelt); Allegro Molto from Sonata No. 6 (Mendelssohn). 12.30, Gramophone Concert. Selection from The Nuremberg Doll (Adam); España (Chabrier); La boîte à joujoux (Debussy); El fandango de Cándid (Durán); Invitation to the Waltz (Weber); Alleluia d'amour (Fauré); Cortège from The Queen of Sheba (Gounod). 1.30 to 2.30, Programme in English by the I.B.C. 1.30, Gramophone Concert. Marche de bravoure (Schubert); Birds of the Forest (Messier); Black Rose (Aubry); Si vous n'étiez pas aussi jolie (Silviano); Tu sais (Erdvante); Waltz, The Sirens (Waldteufel); Gipsy Serenade (Boraganov); Lacartarena (Guerrero). 2.0, Concert of Dance Music. Signature Tune, Happy Feet; Let's all be happy Together; Everybody loves my Marguerite; Spanish Eyes; I like to go back in the Evening; Who's afraid of the Big Bad Wolf; Destiny Waltz; That's what Life is made of; Throw open wide your Window; Signature Tune, Happy Feet. 2.30, Interval. 3.0 to 3.30, Programme in English by the I.B.C. 3.0, Concert. Signature Tune, Night shall be filled with Music; It's never too Late; The Last Round up

(Hill); Hold your Man (Freed); Dinner at Eight (Fields); La mulata rumbera; Experiment (Porter); H'ya Duchess; The Day you came along; Signature Tune. 3.30, Concert of Light Music. 4.0, to 4.15, Programme in English by the I.B.C. Gramophone Concert. Sérénade Tzigane (Boraganov); If you're really and truly in Love (Butler); Manola (Liberaid); Just a Little closer (Johnson). 4.15, Interval. 5.0, Popular Concert. 7.0, Concert of Light Music. 8.0, Music Hall. In the intervals at 8.30, Sports Notes and Weather, and at 9.15, Press Review and News.

**PITTSBURGH**

KDKA, 980 kc/s, 306 metres; 50 kW.—Relayed by W8XK on 48.86 metres, and 25.27 metres.—5.30 to 6.30 p.m., Radio City Concert, from New York. 7.0, Bar X Ranch, from New York. 7.30, Programme to be announced. 8.0 to 9.30, New York Relay. 8.0, International Tid-bits. 8.30, Variety Programme. 9.0, True Railroad Stories. 9.15, Morin Sisters. 9.30, Vesper Services. 10.30, Grand Hotel, from New York. 11.0, Press News-Reeler. 11.15, Weather and Sports. 11.30, Happy Felton's Orchestra. 11.45 to 2.45 a.m. (Monday), New York Relay. 11.45, True Engineering Stories. 12 Midnight, Vincent Lopez Orchestra. 12.30, Joe Penner. 1.0, Egon Petri and Orchestra. 2.0, Gulf Headliners. 2.30, Walter Winchell. 2.45, Marvellous Melodies. 3.0, Orchestral Concert, from New York.

PORSGRUND.—See Oslo.

**PRAGUE**

614 kc/s, 488.6 metres; 120 kW.—10.0 a.m., Concert by the Ondricek String Quartet. 11.0, Chimes. 11.5, News. 11.15, See Moravska-Ostrava. 12.30 p.m., Agricultural Programme. 12.45, Talk. 12.55, Interval. 3.0, See Brno. 4.30, Reminiscences of Life and the Theatre by a Blind Actor. 4.45, Gramophone Music. 5.0, German Transmission: Music Programme Announcements, a Revue and News. 6.0, News. 6.5, Talk. 6.20, Introductory Talk to the following Transmission. 6.30, Act I of Dogheads—Opera (Kovarovics), relayed from the State Opera House. Conductor: Otalear Ostrcil. 7.20, See Brno. 8.0, Time Signal. 8.1, Concert by the Station Orchestra, conducted by Jeremias. Soloist: Daniel (Violin). 9.0, Time, News, and Sports Notes. 9.20, Concert by the Herman Schrammel Ensemble. 10.0 (approx.), Close Down.

**RADIO-SUISSE ROMANDE**

SOTTENS, 743 kc/s, 403 metres; 25 kW., and Geneva, 400 kc/s, 749.9 metres.—8.55 a.m. (from Geneva), Chimes. 9.0 (from Geneva), Protestant Service, relayed from St. Peter's Cathedral. 10.0 (from Geneva), Gramophone Concert. 11.30, News and Weather. 11.40 (from Geneva), Gramophone Concert (contd.). 1.0 p.m., Interval. 2.30, See Schweizerischer Landessender. 4.30, Interval. 5.0 (from Geneva), Gramophone Concert. 6.0 (from Geneva), Catholic Address. 6.30 (from Geneva), Radio Chronicle and Sports Notes. 7.0 (from Geneva), Messa domestica for Orchestra, Soprano and Organ (Grecianinov), with Introductory Talk. 7.35 (from Geneva), Humorous Programme. 7.55 (from Geneva), Concert by the Radio Suisse romande Orchestra, conducted by Echenard. Part I—Romanian Music. Rustic Divertissement (Dragoi). Part II—Suite cévenole (Lauber). 9.0, News and Weather.

RJUKAN.—See Oslo.

**ROME**

Call 1RO, 680 kc/s, 441 metres; 50 kW. Relayed by Naples, 941 kc/s, 319 metres; Milan, Vigentino, 662 kc/s, 453.1 metres; from 7.45 p.m.; and 2RO, 11,810 kc/s, 25.4 metres.—9.0 a.m., News, Sports Notes and Amusement Guide. 9.30, Agricultural Talk. 9.45, Bible Reading. 10.0 to 11.0, See Turin. 11.30, Gramophone Music. 11.45 to 1.15 p.m., See Turin. In the interval at 1.0, Time and Announcements. 3.0 (Naples), Programme for Children Weather and Sports Notes. 3.15, Gramophone Music and Sports Report. 4.0; Symphony Concert conducted by Bernardino Molinari, relayed from the Augusteo; Soloist, Attilio Brugnoli (Pianoforte); Football Report in the interval. 5.30 to 5.35 (approx.), Weather. 6.30, Sports Notes. Dopolavoro Report and News. 7.0, Time and Announcements. 7.30, Sports Notes. 7.45, Addio giovinezza. Operetta in Three Acts (Pietri). In the intervals Talk and Announcements. Giornale Radio after the Operetta.

SALZBURG.—See Vienna.

**SCHENECTADY**

WGY, 790 kc/s, 379.5 metres; 50 kW. Relayed at intervals by W2XAF on 31.48 metres, and by W2XAD, on 19.56 metres.—7.0 to 9.0 p.m. (approx.). New York Relay. 7.0, Gene Arnold and Commodores. 7.30, Looking over the Week, by John Kennedy. 7.45, Gems of Melody. 8.0, Wayne King's Orchestra. 8.30, Musical Programme. 9.0 (approx.) to 12.45 a.m. (Monday), Interval. 12.45 to 3.45 a.m., New York Relay. 12.45,

**BATTERY SET OWNERS!!**

Over 27,000 London listeners are now enjoying amazingly improved reception since discarding dry batteries and joining our "ACCUMULATOR RENTAL SERVICE" which keeps you continuously supplied with either H.T. or L.T. fully charged accumulators, or both, by small monthly or quarterly rental payments. No other H.T. supply can give you such consistently perfect reception.

*Typical Example of our Charges  
(Payable Monthly)*

- 2 volt 120/60 a.h. L.T. accumulator  
4d. per week
- 120 volt 5,000 m.a. H.T. accumulator  
1/2 per week

Therefore you need not buy any more dry batteries or accumulators. This rental service keeps you continuously supplied by regular and punctual exchanges to your door anywhere within 15 miles of Charing Cross. **27,000 London Listeners can't be wrong.** Why not join this economical accumulator rental service and always have the power of an all-mains set with battery set quality from your existing receiver?

Send now for full particulars Dept. R., RADIO SERVICE (London) Ltd., 105, Torriano Avenue, Camden Road, N.W.5. Phone: Gulliver 1091 (4 lines).

**IF YOU CAN AFFORD TO BUY PARMEKO THE SATISFACTION OBTAINED WILL WELL REPAY YOU**

PARTRIDGE & MEE, LTD. LEICESTER AND LONDON.

SPECIALISTS IN HIGH QUALITY TRANSFORMERS, CHOKES, SPEAKERS, AMPLIFIERS

# INSTRUMENTS OF PRECISION FOR WIRELESS CONSTRUCTORS



The illustration shows a group of highly sensitive yet moderately priced instruments which should appeal to the discriminating wireless enthusiast. Ammeters, Milli-ammeters and Voltmeters supplied for flush mounting 1½", 2", 2½" and 3½" diameter, or Projecting type in the 2½" and 3½" sizes.

Send for descriptive literature.

## METROPOLITAN Vickers

SUBSIDIARY OF ASSOCIATED ELECTRICAL INDUSTRIES LTD.  
ELECTRICAL CO., LTD.  
TRAFFORD PARK, MANCHESTER, 17

NOV. 26th

# SUNDAY

 continued

Popular Programme with Wendell Hall. 1.0, Variety Programme. 2.0, Manhattan Merry Go Round. 2.30, American Album of Familiar Music. 3.0, Variety Programme. 3.30, Popular Programme. 3.45, Seth Part, from New York, followed by Programme Resumé.

### SCHWEIZERISCHER

#### LANDESENDER

**BEROMUNSTER**, 653 kc/s, 459 metres; 60 kW; Basle, 1,229 kc/s, 244.1 metres; and **Berne**, 1,220 kc/s, 245.9 metres.—9.0 a.m. (from Zürich), Catholic Service. 9.35 (from Zürich), Swiss Army Festival Programme, relayed from the Town Hall. 10.30 (approx.) (from Zürich), Talk. 11.0 (from Zürich), Gramophone Concert. 11.30, Time, News and Weather. 11.40 (from Zürich), Concert by the Station Orchestra. 12.30 p.m. (from Zürich), Concert conducted by Meyer. 1.0 (from Zürich), Talk. 1.30, Interval. 2.30, Concert by the Harmonie Male Voice Choir, relayed from the Town Hall, St. Gall. 4.30 (from Zürich), Talk in a Foreign Language. 5.0 (from Zürich), Gramophone Concert. 5.30 (from Zürich), Jacob Bühler reads from his Drama, Galileo Galilei. 6.0 (from Zürich), Sports Results. 6.5 (from Zürich), Gramophone Concert. 6.20 (from Zürich), Talk: Technical Progress. 6.50 (from Zürich), Venus—Opera in Three Acts (Schloek), relayed from the Municipal Theatre. 9.30 (approx.), Sports Report and Close Down.

**SOTTENS**.—See Radio-Suisse Romande.

### STOCKHOLM

689 kc/s, 436 metres; 55 kW.—Relayed by **Boden**, 242 kc/s, 1,239.5 metres; **Göteborg**, 922 kc/s, 322 metres; **Hörby**, 1,167 kc/s, 257 metres; **Motala**, 222.5 kc/s, 1,348 metres; **Ostersund**, 402 kc/s, 746.2 metres; and **Sundsvall**, 554 kc/s, 542 metres.—8.0 a.m., Rural Programme. 8.30, Gramophone Music. 9.10, Talk for Workers. 9.30, Talk for Workers, relayed from Uppsala, 662 kc/s, 453.1 metres. 10.0, Divine Service. 11.45, Weather and Ice Report. 1.0 p.m., Recital by Ann-Marie Florin (Songs), and Torval Hagelin (Pianoforte), relayed from Falun, 977 kc/s, 307 metres. 1.30, Talk. 2.0, Songs to the Lute by Eric Møllestedt. 2.20, Gramophone Music. 3.0, Elementary English Lesson. 3.30, Programme for Children. 4.5, Schubert Pianoforte Duets, by Stig Ribbing and Axel Pettersson. 4.30, Reading. 5.0, Evensong, relayed from a Church in Hudiksvall. 6.15, Weather and News. 6.30, Talk, relayed from a Cripples' Home. 6.45, Concert by the Radio Orchestra, conducted by Tor Mann. Soloist: Mauritz van den Berg (Violin). 8.0, Salvation—Radio Play (Martinson). 8.45, Weather and News. 9.0, Light Orchestral Music. 10.0 (approx.), Close Down.

### STRASBOURG

869 kc/s, 345 metres; 11.5 kW.—9.30 a.m., Orchestral Concert, conducted by Maurice de Villars. 10.45, Protestant Service. 11.30, Catholic Service in German. 12 Noon, Gramophone Concert. 12.45 p.m., News. 1.0, Time Signal. 1.1, Gramophone Concert. 2.0, Talk in French on Arboriculture. 2.15, Interval. 3.0, Concert by the Conservatoire Concert Society, relayed from the Conservatoire. 5.0, Organ and Choral Music, relayed from the Catholic Church of St. Pierre-le-vieux. The Parish Choir, conducted by Welker. Soloist: Fernand Rich (Organist). 6.0, Medical Talk in French: Inoculation against Diphtheria. 6.15, Sports Talk in French. 6.30, Orchestral Concert, conducted by Maurice de Villars; Marche militaire (Schubert); Dance of the Waves (Catalani); Overture, The Black Domino (Auber); Selection from The Tales of Hoffmann (Offenbach); Two Arabesques (Debussy); Orchestral Suite from Der Rosenkavalier (R. Strauss). 7.30, Time and News. 7.45, Gramophone Music. 8.0, Press Review in German and Lottery Results. 8.30, Wine—An Alsatian Programme of Songs, Readings and Anecdotes with Bandonian Music. 10.30, Press Review in French, followed by Dance Music from the Savoy. 12 Midnight, Close Down.

### STUTTGART

**MUHLACKER**, 832 kc/s, 360.5 metres; 1.5 kW. Relayed by **Freiburg**, 527 kc/s, 570 metres.—10.30 a.m., See Leipzig. 11.0, Gramophone Concert of Popular Music. 12 Noon, Topical Talk. 12.15 p.m., See Langenberg. 1.15, Agricultural Talk. 1.30, Talk: Music, Men and Animals. 2.0, See Langenberg. 3.0, See Hellsberg. 5.0, Recital of Beethoven Music by Artur Haagen and on Gramophone Records. 5.50, Sports Notes. 6.15, November, The Month of Fogs (arr. Martin Lang). 7.0, Organ Recital by Fritz Hayn, relayed from the Cathedral, Ulm. 7.30 (approx.), See Berlin (Deutschlandsender). 8.10, Concert by the Station Orchestra, conducted by Ferdinand Drost. Soloist: Hans Hermann Nissen (Baritone). 9.0, See Frankfurt. 9.20, Topical Talk. 9.30, Local News, Weather and Sports Notes. 9.40 to 11.0, See Langenberg. 11.0, See Frankfurt. 1.0 a.m. (Monday), Close Down.

**SUNDSVALL**.—See Stockholm.

### TOULOUSE

779 kc/s, 385 metres; 8 kW.—11.45 a.m., Music from Sound Films. 12 Noon, Accordion Solos. 12.15 p.m., Orchestral Music. 12.30, Catholic Service. 12.45, Songs. 1.0, Amusement Guide, Exchange, and Time. 1.5, Opera Music. 1.15, Operetta Music. 1.30, Orchestral Music. 1.45, Protestant Service. 2.0, Chansonnettes. 2.15, Agricultural Report. 2.30, Music by a Viennese Orchestra. 2.45, Opera Music. 3.0, Organ Recital. 3.30, Music from Sound Films. 3.45, Orchestral Concert. 4.15, Opera Music. 4.30, Music by an Argentine Band. 4.45, Light Music. 5.0, Thé dansant. 5.45, Songs. 6.0, News. 6.15, Military Music: Five and Steel (Rathke). 6.30, Russian Songs and Balalaika Music. 6.45, Chamber Music. 7.0, Accordion Solos. 7.15, News. 7.30, Poltsian Dances from Prince Igor (Borodin), by the Station Orchestra. 7.45, Chansonnettes. 8.0, Concert by a Viennese Orchestra. 8.30, Opera Music. 8.45, Hawaiian Guitar Solos. 9.0, Orchestral Music. 9.15, Manon—Opera in Five Acts (Massenet). In the interval at 10.15, News. 11.30, Military Music. 11.45, Music from Sound Films. 12 Midnight, News, Weather, and Announcements. 12.5 a.m. (Monday), Music by an Argentine Band. 12.15, Orchestral Music. 12.30 (approx.), Close Down.

### TRIESTE

1,221 kc/s, 247.7 metres; 10 kW.—8.40 a.m., See Turin. 8.55, Mass from the Cathedral of San Giusto. 10.0, Religious Address. 10.20, Agricultural Talk. 11.0 till Close Down, See Turin.

**TRONDHEIM**.—See Oslo.

### TURIN

1,096 kc/s, 273.7 metres; 7 kW. Relayed by **Milan**, 903 kc/s, 332.2 metres; **Genoa**, 959 kc/s, 312.8 metres; and **Florence**, 598 kc/s, 501.6 metres.—8.40 to 8.55 a.m., Giornale Radio. 9.40, Agricultural Notes. 10.0, Mass from the Church of the Annunciation, Florence. 11.10 to 11.15, Bible Reading. 11.30, Gramophone Music. 11.45, Gramophone Music. 12 Noon, Time and Announcements. 12.2 to 1.15 p.m., Concert of Variety Music. 3.0, Gramophone Music and Sports Notes. 4.0, Concert of Variety Music. Football Report in the interval. 5.0 (approx.), Sports Review of the Day, followed by Weather. 6.0, Time, Football Report, Dopplavoro Announcements and Gramophone Music. 6.15, Gramophone Records of Light Music. 7.0, Announcements, Sports Notes and Gramophone Music. 8.0, An Opera (to be announced). Talk, Theatre Notes and Giornale Radio in the intervals.

### VIENNA

580 kc/s, 517.2 metres; 100 kW. Relayed by **Graz**, 852 kc/s, 352.1 metres; **Innsbruck**, 1,058 kc/s, 283 metres; **Klagenfurt**, 662 kc/s, 453.1 metres; **Linz**, 1,220 kc/s, 245.9 metres; and **Salzburg**, 1,373 kc/s, 218.5 metres.—11.0 a.m., Concert by the Wiener Symphoniker, conducted by Herbert Winkler. Soloist: Toni Sommer-Wirtinger (Pianoforte). 1.0 to 1.35 p.m., Interval. 1.35, Time, Announcements, and News. 1.45, Talk: The Work of the Forester. 2.5, Review of Books. 2.30, Chamber Music by the Philharmonic String Quartet. 3.30, An Entertainment. 3.55, Concert by the Wiener Symphoniker, conducted by Josef Holzer. 5.5, Talk, with Gramophone Illustrations: Wisdom and Humour in African Literature. 5.35, Josephine Widmar reads from her own works. 6.0, Violin and Cello Recital. 6.50, Time, Sports Notes, and Programme Announcements. 7.0, Pension Schöller—Fare in Three Acts (Jacoby and Carl Laufs). 8.45, News. 9.0, Concert by the Wiener Symphoniker, conducted by Holzer.

### WARSAW

212.5 kc/s, 1,411 metres; 120 kW.—9.0 a.m., Speeches by Delegates to the Fifth Congress of the Organisation of Poles Abroad, relayed from the Senate. 10.35, Talk: The Jesuit Fathers in Rhodesia. 10.57, Time and Fanfare from the Tower of St. Mary's Church, Cracow. 11.5, Programme Announcements. 11.10, Weather. 11.15, Concert by the Philharmonic Orchestra, conducted by Armand Balendonck. Soloist: Jeanne Hupert (Mezzo-Soprano). In the interval at 12.30 p.m., Talk: The Industrialisation of Poland. 1.0, Talk: Polish Forests. 1.15, Agricultural Market Prices. 1.25, Concert by the Cathedral Male Voice Choir. 2.0, Talk: Winter Evenings in the Country. 2.20, Concert by the Squire Quintet, on Gramophone Records. 3.0, Programme for Children. 3.30, Gramophone Records of Yehudi Menuhin. 3.45, Talk on Books. 4.0, Talk for Women. 4.15, Programme, relayed from Cracow, 959 kc/s, 312.8 metres. In the interval, Announcements. 5.0, Dramatic Programme. 5.40, Song Recital by Irene Downer-Zapolska (Soprano). 6.0, Programme Announcements. 6.5, Miscellaneous Items. 6.30, Weekly Topical Talk. 6.45, Talk on Art. 6.50, Variety Programme, relayed from Lwow, 788 kc/s, 331 metres. 7.35, Radio Journal. 7.45, New York Baby—Musical Comedy in Five Scenes (Fanny Gordon-Eiger). **ZURICH**.—See Schweizerischer Landessender.

# MONDAY

NOVEMBER THE TWENTY-SEVENTH

## ATHLONE

725 kc/s, 413 metres; 60 kW. Relayed by Dublin, 1,382 kc/s, 217 metres; and Cork, 1,337 kc/s, 22.4 metres.—1.30 to 2.30 p.m., Time Signal, Weather Report, Stock Report and Gramophone Concert. 6.0, Programme for Children. 6.45, News. 7.0, Gaelic Talk. 7.15, Talk: Our Mineral Sources of Wealth. 7.30, Time Signal. 7.31, Concert by the Station Orchestra. 8.0, Variety Programme by Tom Madden and Company. 8.30, Piano-forte Solos by Victor Love. 8.45, Baritone Solos by Richard Browne. 9.0, The Station Orchestra. 9.15, Soprano Solos by Mm. K. McCaffery. 9.30 to 10.30, Programme by the I.B.C. (Ireland), Ltd. 9.30, Concert: A Supper with Suppé (arr. Morena); Intermezzo. Liebesfreud (Kreisler); Song, The Gay Highway (Lockton); Hungarian Dance No. 1 in G Minor (Brahms). 9.45, Concert of Dance Music: I've got to sing a Torch Song; It's within your Power; My Moonlight Madonna; The Grass is getting greener all the Time. 10.0, Concert arranged by the International Broadcasting Company (Ireland), Ltd.: Dance Music, Lazybones; Waltzing alone with you; Remember my forgotten Man; Racing Commentary; Home-made Heaven; Isn't it Heavenly?; Reflections in the Water; Old Timers. 10.30, I.B.C. Goodnight Melody, followed by News and Weather. 10.40, Traditional Fiddle Solos by May Kavanagh. 10.50, Uilleann Pipe Solos, by S. MacAonghusa. 11.0 (approx.), Close Down.

## BARCELONA

EAJ1, 858 kc/s, 349.6 metres; 8 kW.—6.0 p.m., Trio Concert: Trio No. 1 (Couperin); Slav Caprice (Bayer); Canzonetta (Toselli); Les Cloches (Debussy); Waltz Scherzo (Liadov); Der Erlkönig (Schubert). 7.0, Request Gramophone Music. 7.20, Sports Notes. 7.30, Exchange and Talk in Catalan. 8.0, Gramophone Music and News. 8.30, Educational Programme: Geography and History Lesson. 9.0, Chimes, Weather, Exchange, and Market Prices. 9.5, Humorous Review of the Week in Verse. 9.45, Concert of Sardanas. 10.0, Concert by the Radio Orchestra. 11.0, News and Dance Music from the Casa Llibre. 12 Midnight (approx.), Close Down.

## BARI

1,112 kc/s, 269.8 metres; 20 kW.—3.30 p.m., Gramophone Music. 3.55 (approx.) to 7.0, See Rome. 7.0 to 7.15, News in Albanian. 7.30 (approx.) till Close Down, See Rome.

BASLE.—See Schweizerischer Landessender.

## BELGRADE

698 kc/s, 429.7 metres; 2.8 kW.—6.0 p.m., Popular Music on Gramophone Records. 6.30, Violin Recital by Vladimir Slatiu. 7.0, Talk. 7.30, Manon, Opera (Massenet), on Gramophone Records. In the interval at 9.0, Time and News.

## BERLIN

DEUTSCHLANDSENDER (REICHSENDER), 183.5 kc/s, 1,635 metres; 60 kW.—11.5 a.m. (approx.), Gramophone Concert of Opera Music: Overture, Il Seraglio (Mozart); Aria from The Magic Flute (Mozart); Overture, The Barber of Bagdad (Cornelius); Duet from The Barber of Seville (Rossini); Aria from Czar and Carpenter (Lortzing); Overture to and Aria from The Merry Wives of Windsor (Nicolai); Selection from Der Wildschütz (Lortzing); Dance of the Apprentices from The Master-singers (Wagner); Overture, The Bartered Bride (Smetana); Aria and Waltz from Hansel and Gretel (Bumperdinck). 11.55, Time Signal. 12 Noon, Interval. 12.45 p.m., News. 1.0, Gramophone Concert: Mephisto-Walker (Liszt); Movement from the Fantastic Symphony (Berlioz); Das Hexenlied (Max von Schillings); L'apprenti sorcier (Dukas); Dance from Pictures from an Exhibition (Mussorgsky). 2.0, Talk for Women. 2.30, Weather and Exchange. 2.45, Review of Books. 3.0, See Breslau. 4.0, Discussion: The Vocational Training of Young People. 4.25, Tag und Nacht, String Quartet Op. 2 (Rudolf Peterka). 5.0, Poems. 5.5, Talk on Sport. 5.20, Talk: The Motor Mechanic. 5.30, Talk: The Problem of Land and House Buying. 5.50, Weather and Announcements. 6.0, Transmission for all German Stations, relayed from Stuttgart. 7.0, See Berlin (Funkstunde). 7.5, Learning to Ski-run. 7.20, Talk on Tchaikovsky, on the fortieth anniversary of his Death. 7.30, Concert by the Augmented Station Orchestra, conducted by Edwin Lindner: Soloist, Gaspar Cassado (Cello); Romeo and Juliet (Tchaikovsky); Cello Concerto in B Minor (Dvorak); Carniva (Scherber). 9.0, News. 9.30, Talk. 9.45, Weather. 10.0, See Munich.

## BERLIN

FUNKSTUNDE, 716 kc/s, 419 metres; 1.5 kW. Relayed by Zeesen, DJC, DJA, DJD, DJB, and DJE.—3.0 p.m., Seven Variations for Cello and Piano-forte on a Melody from Mozart's The Magic Flute (Beethoven), played by Casals and Cortot, on Gramophone Records. 3.15, Talk: A Visit to Burg Saaleck. 3.30, Thé Dansant from the Hotel Esplanade. 4.50, Talk on Schmidt von Wernaeuchen. 5.10, Variations and Fugue for Piano-forte on a Theme of Telemann (Reger). 5.30, The Funkstunde informs its Listeners. 5.45, Topical Talk. 6.0, Transmission for all German Stations, relayed from Stuttgart.

7.0, Radio Report from the Christmas Tree Decoration Industry in the Thuringian Forest. 7.5, Contemporary Chamber Music by the Kampfbund Quartet: String Quartet in A Minor, Op. 6 (Helmut Schaefer); First String Quartet (Kurt Fiebig). 8.0 to 9.0, See Hamburg. 9.0, News. 9.20 (approx.) till Close Down, Programme from Hamburg. 11.0 (approx.), Close Down.

BERNE.—See Schweizerischer Landessender.  
BEROMUNSTER. — See Schweizerischer Landessender.

BODEN.—See Stockholm.

BODO.—See Oslo.

## BRATISLAVA

1,073 kc/s, 279.5 metres; 14 kW.—5.25 p.m., Symphony No. 1 in C. Op. 21 (Beethoven), by the Station Orchestra, conducted by Dyk. 5.55, Hints for Housewives. 6.0, See Prague. 6.10, See Brno. 6.25, Gramophone Music. 6.40, See Prague. 6.55, Concert of Light Music by the Station Orchestra. 7.20, Uncle Matthew—a Folk Play in Three Acts, with Songs (Urbanek), for the Author's Seventy-Fifth Birthday. 9.0, See Prague. 9.15 (approx.), Close Down.

BREMEN.—See Hamburg.

## BRESLAU

923 kc/s, 325 metres; 60 kW. Relayed by Gleiwitz, 1,185 kc/s, 253.1 metres.—10.55 a.m. (approx.), Concert by the Station Orchestra, conducted by Ernst Topitz. In the interval from 12.45 to 1.10 p.m., Time and News. 1.40, Programme arranged by the Post Office, with Gramophone Records. 2.0, Market Prices. 2.20 (from Gleiwitz), Talk: Traces of the Ice Age in Upper Silesia. 2.40, Review of Books on Luther. 3.0, Concert by the Andreozzi Orchestra, relayed from the Vier Jahreszeiten Café. 4.50, Agricultural Notes. 4.55, Talk: Genealogy. 5.10, Technical Talk. 5.20, Topical Talk. 5.40, Programme Announcements and Meat Market Prices. 6.0, Transmission for all German Stations, relayed from Stuttgart. 7.0, News. 7.10, Symphony Concert by the Silesian Philharmonic Orchestra. Part I, conducted by Joachim Albrecht, Prince of Prussia. Festival Overture (Prince Joachim Albrecht of Prussia); Prince Louis Ferdinand Fantasia (Prince Joachim Albrecht of Prussia); German Fantasia (Prince Joachim Albrecht of Prussia). Part II, conducted by Franz von Hoesslin: Symphony in D, No. 38 (Mozart). 9.0, See Munich. 9.20, Time and News. 9.50, Serenade on Gramophone Records. 11.0 (approx.), Close Down.

## BRNO

878 kc/s, 342 metres; 35 kW.—5.25 p.m., German Transmission: News, Recitations and a Report on Brno Exhibitions. 6.0, See Prague. 6.10, Talk. 6.25, Song Recital. 6.40, See Prague. 6.55, Organ Recital by Jiri Reinberger, relayed from the Stadium: Prelude and Fugue in D (Bach); Concerto in E (Handel). 7.25 till Close Down. See Prague. 9.30 (approx.), Close Down.

## BRUSSELS (No. 1)

I.N.R., 589 kc/s, 509.2 metres; 15 kW.—12 Noon, Gramophone Music: Selection from Don Pasquale (Donizetti); Ballet Music from Les aventures du roi Pausole (Honegger); Overture, Light Cavalry (Suppé). 1.0 p.m., Le Journal Parlé. 1.10, Concert by the Small Station Orchestra, conducted by Pierre Leemans. 2.0, Broadcast for Schools. 5.0, Concert by the Station Symphony Orchestra, conducted by Arthur Meulemans: Overture, Aeneis (Uytendhove); Two Elegiac Melodies (Grieg); Song and Scherzo for Wind Instruments (Florent Schmitt); Fantasia on Two Angevin Airs (Lekeu); Fantasia on a Walloon Christmas Carol (Ysaye); Marche héroïque (Saint-Saëns). 6.0, Talk: Oliver Cromwell. 6.15, Gramophone Music: Two Arias from Werther (Massenet); Duet from Act I of Faust (Gounod). 6.30, Concert by the Small Station Orchestra, conducted by Leemans: Cortège, Louis XIII (Fauchey); Impressions rustiques (Razigade); Cantilène (Van Goens); Danse caractéristique (Saëys); Selection from La dame verte (Ferrarese); La romanesca from La Vannina (Bastide); Petite Suite No. 2 (Gilson); Idylle slave (Ackermans); Old Songs (Broustet). 7.30, Theatre and Film Review. 8.0, Concert by the Radio Orchestra, conducted by Walpot: Marche militaire française (Saint-Saëns); Overture, Le roi d'Ys (Lalo); Extase (Ganne); Selection from Le petit duc (Lecocq). 8.30, L'appel des ailes—Radio Play (Jacques Prieux). 9.10, Noces d'or—Musical play (Maurage); The Radio Orchestra, conducted by Charles Walpot; Soloists, Suzanne de Gavre (Soprano), Armand Crabbé (Baritone), and Hellinckx (Bass-Baritone). 10.0, Le Journal Parlé.

## BRUSSELS (No. 2)

N.I.R., 888 kc/s, 337.8 metres; 15 kW.— Programme in Flemish. 12 Noon, Concert by the Small Station Orchestra, conducted by Pierre Leemans: March, Vivat Hungaria (Kálmán); Waltz, Gold and Silver (Lehár); Aubade printanière (Lacombe); Selection from The Drum-Major's Daughter (Offenbach); Violin Solo: The Canary (Poliakin); Dance of the Merry Mascots (Ketilbey); Selection from Gri-Gri (Lincke); The British Patrol (Asch); Selection from La Dame en décolleté (Yvain). 1.0 p.m., Le Journal Parlé. 1.10, Gramophone Concert: Selection from The Merry Widow (Lehár); Extract from The Land of Smiles (Lehár); Air from Norma (Bellini); Selection from Foli, low a Star (Yellen); Polka, The Canary and the Frog; Selection from Rigoletto (Verdi); Dances (Lanner); Quadrille from Orpheus in the Underworld (Offenbach). 2.0, Educational Programme. 5.0, Concert by the Radio Orchestra, conducted by Charles Walpot: Marche jubilaire (De Boeck); Extract from Gretina Green (Guiraud); Overture (Luigini); Selection from The Three Musketeers (Friml); Meditation for Violin and Orchestra (Maes); Extract from the Nutcracker Ballet (Tchaikovsky); Rubens-Marche (Benoit). 5.45, Programme for Children. 6.30, Gramophone Music. 7.15, Horticultural Talk. 7.30, Variety Item. 8.0, Concert by the Symphony Orchestra, conducted by Arthur Meulemans: Overture, The Merry Wives of Windsor (Nicolai); Extract from Sylvia (Delibes); Pastorale (Pierné); Vaises romantiques (Chabrier). 8.45, Talk: The Fiscal System. 9.0, Concert (contd.). 10.0, Le Journal Parlé.

## BUCHAREST

761 kc/s, 394 metres; 12 kW.—4.0 p.m., Concert by the Station Orchestra: March (Ertl); Waltz from The Arabian Nights (Joh. Strauss); Overture, Flotte Bursche (Suppé); Suite No. 1 from L'Arlesienne (Bizet); Selection from Gasparone (Müllöcker); Selection from Samson and Delilah (Saint-Saëns); Wiegeliend (Fück); Foxtrot on Themes from Die Fledermaus (Joh. Strauss-Kochmann). In the interval at 5.0, Radio Journal, and at 5.15, Song Recital. 6.0, Educational Talk. 6.20, Gramophone Music. 6.45, Light Music on Gramophone Records. 7.0, Chamber Music by the Sarvache Quartet. 7.30, Talk. 7.45, Recital of Operetta Arias by Nia Roma. 8.15, Pianoforte Recital by Cella Delavrancea-Lahovary. 8.45, Radio Journal. 9.0, Romanian Music by the Station Orchestra.

## BUDAPEST

545 kc/s, 550.5 metres; 18.5 kW.—Also relayed on 840 metres from 7.45 p.m. till Close Down. 4.30 p.m., Gramophone Music. 5.30, Programme for Workers. 6.0, Song Recital by Wilhelm Gregor. 6.30, Talk. 7.0, Clarinet Recital by Julius Vaezi; Clarinet Concerto in F Minor, Op. 73, No. 1 (Weber); Canzonetta, Op. 19 (Pierné); Fantasia on Rigoletto (Verdi). 7.30, News. 7.45, Orchestral Concert, conducted by Freccia Massimo, relayed from the Academy of Music. Soloist: Arnold Földessy (Cello). Passacaglia (Bach-Respighi); Cello Concerto (Hubay); Suite, Mother Goose (Ravel); Pictures from an Exhibition (Mussorgsky-Ravel). Weather in the interval. 9.50, Concert of Light Music relayed from the Patria Café.

CASSEL.—See Frankfurt.

## COPENHAGEN

1,067 kc/s, 281 metres; 0.75 kW. Relayed by Kalundborg, 260 kc/s, 1,153.8 metres; and Skamlebaek OXY, 49.4 metres; 0.5 kW.—11.0 a.m., Time Signal and Chimes from the Town Hall. 11.2, Concert by the Harald Andersen String Ensemble, relayed from the Hotel d'Angleterre. 1.0 p.m., Interval. 2.20, Talk for Housewives. 2.30, Concert by the Radio Orchestra, conducted by Emil Reesen: Overture, Le roi d'Ys (Lalo); Suite, Summer Days (Coates); Lyric Suite (Grieg); Triume (Wagner-Svendson); Selection from Hansel and Gretel (Humperdinck); Overture, Die schone Galathee (Suppé). In an interval at 3.15 (approx.), Reading. 4.30, Exchange and Fish Market Prices. 4.45, Talk. 5.15, Elementary English Lesson. 5.45, Weather. 5.54, Announcements. 6.0, News. 6.15, Time Signal. 6.16, Discussion: Christianity and Modern Science. 7.15, Concert of Opera Music by the Radio Orchestra, conducted by Launy Gröndahl: Overture, Norma (Bellini); Dances from The Bartered Bride (Smetana); Selection from Faust (Gounod); Overture, Sicilian Vespers (Verdi); Smugglers March from Carmen (Bizet); Entry of the Guests into the Wartburg, from Tannhäuser (Wagner). 8.5, Mands Overmand (Man's Master)—Radio Sketch (Soyu). 8.25, Saxophone Duets by Poul Kisbye and Ejgil Mortensen. 8.45, Et netligt Besög (A Nocturnal Visit)—Sketch (Rudolf Löwit), arranged for Radio,

9.0, News. 9.15, Concert of Chamber Music, by the Gerhard Raftn Quartet: String Quartet in A, Op. 33, No. 6 (Boccherini); String Quartet No. 47 in F minor (Haydn). 10.0, Dance Music, relayed from the Palace Hotel. 11.30 (approx.), Close Down.

CORK.—See Athlone.

DANZIG.—See Heilsberg.

DRESDEN.—See Leipzig.

## FECAMP

1,328 kc/s, 225.9 metres; 10 kW.—11.0 a.m. to 12 Noon, Programme in English by the I.B.C. 11.0, Happy Hour. Part I, Orchestral Concert: Signature Tune, March of the Russian Hussars; Waltz from The Gipsy Princess (Kálmán); Accordion Solo: La Tourterelle (Demaré); Black Eyes (Ferraris); Venetian Boatman's Song (Mantovani); Little Romany (Leon); Accordion Solo: Restless Fingers (Cuvelier); Passion Flower (Kennedy). Part II, Dance Music: Goofus (King); If you'll say Yes Cherie (Noble); Vilja (Lehár); There's a Cabin in the Pines (Hill); Dawn in Moufmartre (Demaré); Moths around the Candle Flame (Randall); The Last Round Up (Hill); It's the Talk of the Town (Symes); Signature Tune. 12 Noon, French Programme. 3.30 to 5.0, Programme in English by the I.B.C. 3.30, Orchestral Concert: Nautical Moments (arr. Winter); Pale Voigt Moon (O'Flanagan); Song, Throw open wide your window, dear (Culson); Selection from Wiener Blut (Strauss); By the Swanee River (Myddleton); Violin Solo: Bohemian Song (Baldy); Barcarolle (Waldteufel); Intermezzo (arr. Ancelet). 4.0, Dance Music: Signature Tune, Bells of Normandy; The Wedding of Mr. Mickey Mouse; Whistling under the Moon; Ah, but it's Love; Cornflowers and Poppies; You're an Old Smoothie; Everyone loves my Marguerite; To-night; A Couple of Pats; Signature Tune, The Bells of Normandy. 4.30, I.B.C. Nursery Corner: Birthday Greetings and Trumpets. 4.40, Chiefter and Boguor Concert of Gramophone Records: Signature Tune, The Night by the Sea; Anytime, anytime, anywhere (Washington); Tony's Wife (Adamson); Thanks (Coslow); Fairy Tale (Heykens); My Moonlight Madonna (Fibich). A Smoking Concert: Part I, Pity me; Dancing Butterfly (Young); Veterans of Variety; Grieg Potpourri (arr. Urbach). 5.20, Hastings and Eastbourne Concert of Light Music: Pan and the Wood Goblins (Rathke); In Tulip Time beside the Water Mill (Albouth); Song, Letting in the Sunshine (Gay); Narcissus (Nevin); Vienna, Vienna (Foss); Banjo Solo: Viva la Libertá; Song, Having a Good Time (Kallal); Russian Rhapsody (Nussbaum); Still I love her (Gaskill); Last Night I dreamed of you (Kálmán); Snacks in Bars (Egerer); Signature Tune. 6.0, French Programme. 10.0 till Close Down, Programme in English by the I.B.C. 10.0 (approx.), Accordion Band Music: All over Italy (Butler); Lucassi March (Lucassi); Medley of Swedish Airs; C'est un petit nid (Ehlinger); Flor d'Espagne (Vola); Perdita (Cuvelier); La Javanette (Bozi); Jaime la Musique (Parsons). 10.30, Dance Music: Signature Tune, Bells of Normandy; Symphony of the Breeze (Leon); Elvira (Paolita); Throw open wide your window (May); Moths around the Candle Flame (Randall); Dinner at Eight (Fields); Solitario (Borli); Shadows on the Swanee (Young); The Last Round Up (Hill); Signature Tune. 11.0, Talkie Time: Signature Tune, Sittin' in the Dark; The Shadow Waltz (Dubin); The little Company (Ganglberger); Selection from Wild Violets (Stolz); Smilin' Through (Penn); Song from White Horse Inn (Benatzky); There's Magic in the Air (Eyton); Mrs. Bartholomew (Ellis); Whoopee Medley (Kahn); Signature Tune. 11.30, I.B.C. Club Concert for Brecknock Listeners. Part I, Military Band Music: Signature Tune, The Chunn Song; Overture, Morning, Noon and Night (Suppé); Post Horn Gallop (Koening); Joanna (Rhys and Cymry); A Birthday Serenade (Lincke); King's Guard (Kietli); Music from Noel Coward's Cavalcade; The Battle of Waterloo (Eckersberg); Gaiety Echoes. 12.5 a.m. (Tuesday), I.B.C. Late News Bulletin. 12.10 (approx.), Club Concert (continued). Part II: Tick, Tock; Good-night little Girl of my Dreams; What a Perfect Combination; Aloha Oe; Well done Gordon; Signature Tune. 12.30, Dance Music: Smoke Rings; Si, Si; Ninon; Dancing Butterfly; If you'll say Yes Cherie; My Own; Isn't this a Night for Love; Wood Violets. 1.0, Dance Music: Signature Tune, Bells of Normandy; Trouble in Paradise; Who's afraid of the Big Bad Wolf; Lou'siana Lullaby; Ding, Dong, Ding; Morning, Noon and Night; Mi amor esta en el Valle; The Cage in the Window; My Moonlight Madonna; Sing another Line; Lazybones; Wedding of the Dragonflies; I've got to get up and go to work; The Three Trees; I've found the Right Girl; Sweet Dreams Pretty Lady; Carry me back to Green, Green Pastures; Oh Johanna. 2.0, I.B.C. Goodnight Melody and Close Down.

FLENSBURG.—See Hamburg.

FLÖRENCE.—See Turin.

## FRANKFURT

1,157 kc/s, 259.3 metres; 17 kW. Relayed by Cassel and Trier, 1,157 kc/s, 259.3 metres.—12.15 p.m., Time and News. 12.25, Local

NOV. 27th

**MONDAY** continued

News and Weather. 12.35, See Stuttgart. 1.40, Talk with Gramophone Illustrations: Folk Songs of the German Provinces. 2.30, Weather. 2.40, Time and Exchange. 3.0, Orchestral Concert: Soloist, Anita Franz (Soprano). 5.0 to 5.35, See Stuttgart. 5.35, Talk: A Student in the Wild West. 5.50, Weather, News, Exchange, Programme Announcements and Time Signal. 6.0, Transmission for all German Stations, relayed from Stuttgart. 7.0, Topical Talk. 7.10, November, 1933, Topical Programme. 8.0, Concert from the Saalbau: Symphony No. 6 in A (Bruckner) by the Frankfurt Symphony Orchestra, conducted by Hans Roshand. 9.0, Time and News. 9.20, See Stuttgart. 9.30, Local News and Weather. 9.45, See Stuttgart. 10.0, See Leipzig. 11.0, See Langenberg. 12 Midnight, Close Down.

FREDRIKSSTAD.—See Oslo.

FREIBURG.—See Stuttgart.

GENEVA.—See Radio-Suisse Romande.

GENOA.—See Turin.

GLEIWITZ.—See Breslau.

GOTEBORG.—See Stockholm.

GRAZ.—See Vienna.

HAMAR.—See Oslo.

**HAMBURG**

806 kc/s, 372 metres; 1.5 kW. Relayed by Bremen, 1,112 kc/s, 269.8 metres; Flensburg and Hanover, 1,319 kc/s, 227.4 metres; and Kiel, 1,292 kc/s, 232.2 metres.—6.0 p.m., Transmission for all German Stations, relayed from Frankfurt. 7.0, Halliglut, A Play in North German Dialect in Two Acts (Paul Friedrich Juels). 8.0, Ballad Recital by Richard Beckmann (Pianoforte); Two Ballads, op. 118 No. 3 and Op. 10 No. 1 (Brahms); Two Ballads in G Minor, Op. 23 and F Sharp, Op. 36 (Chopin). 8.30, Heinrich Zerkauken reads from his new book, Die Männerfuhrer. 9.0, Time and News. 9.20, Concert of Light Music from the Bahnhofs-Gaststätte. 10.0, Cabaret Programme on Gramophone Records.

HANOVER.—See Hamburg.

**HEILSBURG**

1,085 kc/s, 276.5 metres; 60 kW. Relayed by Danzig, 671 kc/s, 447.1 metres.—10.30 a.m., Concert by the Small Station Orchestra, conducted by Eugen Wilcken: Overture (Azzoni); Two Pieces (Beccé): (a) Leggenda d'amore, (b) Melody; First Suite (de Micheli); Overture, Romeo and Juliet (Bellini); Serenata (Tarongizi); Selection from Luterzia Borgia (Donizetti); Serenade from I Medici (Leoncavallo); Brise de mer (Leoncavallo); Overture, Semiramide (Rossini); Marche sauvage (Pietro Florida). 12.1, Time and Weather. 12.5 p.m., The Rhine—Gramophone Concert. In the intervals at 12.20 and 1.0, News. 2.0, Market Prices. 2.30, Programme for Children. 3.0, Concert by the Small Station Orchestra, conducted by Eugen Wilcken: Overture, Le Cheval de Bronze (Auber); Cockney Suite (Kettelhey); Selection from The Carnival Fairy (Kálmán); Terezo-Walzer (Translatour); Debreczin (Meisel); Waltz Intermezzo, Handsome (Köhler); Musikalisches Kunterbunt (Schmalstich); Overture to a Revue (Lincke). In the interval at 4.0, Technical Talk. 4.55, Elementary English Lesson. 5.15, Market Prices. 5.25 (from Danzig), Talk: Danzig in the Middle Ages. 5.50, Weather. 6.0, Transmission for all German Stations, relayed from Frankfurt. 7.0, News and Weather. 7.10, Music and Wine—Concert of Drinking Songs, with Commentary: Frisch auf, ihr Musikanten—Cantata for Four Voices (Gleffe); Drinking Songs for Choir and Harpsichord (Friedrich and Schein); Drinking Songs, for Solo Voice, Strings and General Bass (Heinrich Albert and Adam Krieger); The Nuremberg Quodlibet for Voices and Instruments (Erasmus Kindermann); Songs and Quodlibets from the Augsburg Tafelkonfekt; Drinking Songs (Haydn and Mozart). 8.10, Reading (Wolfgang Herrmann). 8.35, Pianoforte Recital by Hildegard Scharnick: Three Pieces from Stimmungsbilder, Op. 9 (Richard Strauss): (a) Auf stillem Waldespfad, (b) Intermezzo, (c) Träumerei; Variations on a Russian Folk Song, Op. 55 (Paul Graener). 9.5, News and Weather.

**HILVERSUM**

1,013 kc/s, 296.1 metres; 7 kW. up to 5.40 p.m., and 20 kW. from 5.40 p.m. Programme of the Workers' Radio Society (V.A.R.A.)—11.40 a.m., Concert by the Small V.A.R.A. Orchestra, 1.10 p.m., Gramophone Music. 1.25, Concert of Light Music. 1.55, Concert by the Small V.A.R.A. Orchestra, conducted by de Groot: Wir gehen an der Mosel vorüber (Cornelius); Flirtation (Steck); Whistle for me (Faue); Flower Song (Lange); La Matteilchie (Clerd); Serenade (Moszkovsky); Salut d'amour (Elgar); Pierrot's March (Rosa). 2.25, Interval. 2.40, Violin and Pianoforte Recital by Gerter and Wins: Sonata in D (Nardini); Sérénade mélancolique, Op. 26 (Tchaikovsky); Rondino, Op. 32 (Vieuxtemps). 3.10, Talk with Gramophone Illustrations. 4.10, Programme for Children. 4.40, Song and Organ Recital by De Booy and Steyn: Torna a Sorriento (di Capua); Viens danser quadrème (Delettre); Two Serenades (Leoncavallo); Ich liebe dich (Grieg); Melody (Tosti); Selection from Benvenuto Cellini

(Diaz); Parlatemi d'amore (Bixio); Bravo, Bravo (Mcrena). 5.43, Concert of Light Music. 6.10, Talk on Music with Illustrations by Wertheim (Harpsichord), Mendes (Viola d'amore), and Lentz (Viola da Gamba). 6.50, Book Review. 7.10, Concert by the V.A.R.A. Orchestra, conducted by De Groot; Soloist, Aramesco (Songs); Overture, Pinorah (Meyerbeer); Songs: (a) Aria from L'Africaine (Meyerbeer), (b) Cavatina from Faust (Gounod); Selection from Le jongleur de Notre Dame (Massenet); Aria from Carmen (Bizet); Bacchanal from Samson and Delilah (Saint-Saëns). 7.50, S.O.S. Messages. 7.52, Recital by Wertheim (Harpsichord), Mendes (Viola d'amore), and Lentz (Viola da Gamba). 8.10, Concert (contd.): Overture, Gipsy Love (Lehár); Aria from Gipsy Love (Lehár); Aria from The Czarevitch (Lehár); Selection from A Waltz Dream (O. Straus); Songs: (a) Du bist mein Traum (Strauss-Korngold), (b) Die eine Frau (Strauss-Korngold); Selection from Countess Maritza (Kálmán). 8.55, Press Review and Gramophone Music. 9.10, Concert (contd.): French Comedy Overture (Keler-Bela); Hindu Song (Rimsky-Korsakov); Dance of the Derivishes (Bendix); Petite Suite de Concert (Coleridge-Taylor). 9.40, Het einde van de Union—Radio Play (Johansen). 10.30, Concert of Light Music.

HORBY.—See Stockholm.

**HUIZEN**

160 kc/s, 1,875 metres; 7 kW. until 3.40 p.m. Transmitted from Kootwijk on 50 kW. from 3.40 p.m. Programme of the Christian Radio Society (N.C.R.V.). 11.40 a.m., Police Notes. 11.55, Gramophone Music. 12.10 p.m., Organ Recital by Zwart: Sonata (Borowsky); Four Psalms (Zwart); Sonata (Mendelssohn); Pieces for Organ (Zwart); Sonata, Dankt, dankt man alle Gott (Marknll); Finale on Dutch Songs (Zwart). 1.40, Broadcast for Schools. 2.15, Talk on Gardening. 2.55, Dress-making Lesson. 3.25, Interval. 3.40, Concert by the Arnhem Instrumental Trio: Trio No. 29 in F (Haydn); Mignette (Missa); Swedish Scenes (Pedre); En filant la blanche laine (Pesse); Symphony (de Snetskey); Selection from Jeanne d'Arc (Gounod-Alde); T'amo ancora (Tosti); Andante from the Sonata Op. 53 (Beethoven); Sonata No. 4 in C (Bach); Chor, Eine feste Burg (van U'Kruys-Warriors). 6.10, Answers to Correspondence. 6.40, Police Notes. 6.55, Religious News. 7.10, Answers to Correspondence (contd.). 7.40, Concert by the N.C.R.V. Orchestra, conducted by Murk; Soloist, Visser (Organ); Prelude and Fugue on Eine feste Burg (Fischer); Paraphrases; Flower Song (Lange); Four Dutch Songs; Overture, Pique Dame (Suppé); Potpourri (Morena); Nocturne (Chopin); Ständchen (Heykens); Salut d'amour (Elgar); Barcarolle (Fétras); Rustle of Spring (Sinding). In the interval at 8.40, Talk, and at 9.40, News. 10.10, Gramophone Music. 11.10 (approx.), Close Down.

INNSBRUCK.—See Vienna.

**JUAN LES PINS**

NICE, 1,205 kc/s, 249 metres; 0.8 kW.—8.0 p.m., Amusement Guide, Financial Report, Exchange and News. 8.10, Sports Review. 8.20, Concert. 9.0, Announcements and Weather. 9.15, Dramatic Programme. 10.30, Special Transmission for Central Europe: Concert, Melodious Memories (Finck); Trees (Rasbach); Stardust (Carmichael); Waltz (Strauss); Waltz, The Blue Danube (Joh. Strauss); Saschinka (Schirman); Selection from Mother of Pearl (O. Straus); Spanish March (Franco); The Wedding of Pierrette (Jordan); Kern; Potpourri; Gershwin; Potpourri; Selection from The Maid of the Mountains (Fraser Simson) Irish and Welsh Melodies (arr. Somers); Dreams of the Ocean (Gungl); Très jolie (Waldteufel); In a Monastery Garden (Kettelhey); None but the Weary Heart (Heykens).

KALUNDBORG.—See Copenhagen.

KIEL.—See Hamburg.

KLAGENFURT.—See Vienna.

KOSICE.—See Prague.

**LANGENBERG**

635 kc/s, 473 metres; 60 kW.—12.25 p.m., News and Weather. 12.35, See Stuttgart. 1.30, Meat Market Prices. 2.0, Discussion on Insurance. 2.30, Exchange. 2.50, Political Announcements. 3.0 to 5.0, See Frankfurt. 5.0 to 5.35, See Stuttgart. 5.35, Review of the Week. 5.30, Announcements. 6.0, Transmission for all German Stations, relayed from Stuttgart. 7.0 to 9.0, See Frankfurt. 9.0, See Frankfurt. 9.20, See Stuttgart. 9.30, News, Weather and Sports Notes. 9.45 to 11.0, See Stuttgart. 10.0, See Leipzig. 11.0, Schubert Concert on Gramophone Records: The Trout Quintet in A, Op. 114; The Unfinished Symphony. 12 Midnight, Close Down.

LAUSANNE.—See Radio-Suisse Romande.

**LEIPZIG**

770 kc/s, 389.6 metres; 120 kW. Relayed by Dresden, 941 kc/s, 319 metres.—11.5 a.m., Concert by the Station Orchestra, conducted by Theodor Blumer: Overture, Così fan tutte (Mozart); Adagio, Allegro, Minuet and Finale from the Military Symphony in G, No. 100 (Haydn); Waltz, Aquarellen (Jos. Strauss); Petite Suite (Debussy); Overture, The Merry Wives of Windsor (Nicola); Liebesliederwalzer (Brahms); Radetzky March (Joh. Strauss). 12.15 p.m., News. 12.30, Gramophone Concert: Marches; Potpourri of Verdi Music; Song from Martha (Flotow); Potpourri of Puccini Music; Waltz, Die Schönbirner (Lanner). 1.15, News. 1.30 to 1.40, Notes on Art. 1.55, A Visit to a Thuringian Toy Making Town (on Gramophone Records). 2.35, Exchange. 3.0, Concert. 4.0, German Classics: Das Lalenbuck von den Schildbürgern. 4.20, Chaconne in G with Variations (Handel); Twelve Variations in C (Beethoven); Variations in B flat (Schubert). 4.50, Die Minnesänger—a Radio Sequence with Songs to the Lute. 5.20, St. Mechtild of Magdeburg. 5.40, Exchange and News. 6.0, Transmission for all German Stations, relayed from Stuttgart. 7.0, Cabaret and Dance Music by the Emde Orchestra and Soloists. 9.0, News and Sports Notes. 10.0, Concert by the Station Orchestra, conducted by Theodor Blumer. Soloists: Erich Kindischer (Violin) and Alfred Jehmlich (Viola). Overture, Der dumme August (Glaier); Selection from Der Tenor der Herzogin (Künneke); Violin Solos: (a) Taugo (Albeniz), (b) La capricieuse (Elgar); Waltz, The Blue Danube (Joh. Strauss); Selection from Little Ida's Flowers (Kleiman); Allegro and Scherzo for Viola and Pianoforte (Koch); North German Peasant Dances (Holzner); Gallop, Prestissimo (Waldteufel); Prinz Eitel Friedrich—March (Blenkenburg). 11.0 (approx.), Close Down.

LINZ.—See Vienna.

**LUXEMBOURG**

252 kc/s, 1,191 metres; 200 kW.—Italian Evening.—7.0 p.m., Italian Opera Music on Gramophone Records. 7.45, Concert by the Station Orchestra, conducted by Henri Pensis. 8.50, News in French. 9.0, Recital of Italian Songs and Arias by Marie-Thérèse Grosfils-De-Cuyper. 9.30, Gramophone Music. 9.50, News in German. 10.0, Concert by the Station Orchestra, conducted by Henri Pensis. Petite Suite No. 1 (Micheli); Hiawatha (Moret); The Phantom Brigade (Myddleton); March, King Cotton (Souza). 10.25, Dance Music on Gramophone Records.

**MADRID**

ARANJUEZ (EAQ), 10,000 kc/s, 30 metres; 10 kW.—10.30 p.m., Popular Music. 10.45, Radio Chronicle. 11.0, Programme for Catalans Abroad. 12 Midnight till Close Down, I.B.C. Concert of Light Music: Hawaiian Sunset (Vandersloot); The Skater's Waltz (Waldteufel); Oh, Sailor Belave (Dubin); Garbo Gitano (Bruguera); That's my Home (Rene); Uoho, you can't ride this Train (Armstrong); The Cuban Love Song (Stohart). 12.30 a.m. (Tuesday), I.B.C. Good-night Melody and Close Down.

**MADRID**

EAJ7, 707 kc/s, 424.3 metres; 2 kW.—7.0 p.m., Chimes, Exchange, Topical Talk, Recitations and Dance Music. 8.15, Radio Journal. 8.30 (approx.), Close Down.

MALMO.—See Stockholm.

MILAN.—See Turin.

**MORAVSKA-OSTRAVA**

1,137 kc/s, 263.8 metres; 11 kW.—3.0 p.m., Concert by the Station Orchestra, conducted by Musil: Overture, Russian and Ludmilla (Glinka); Ballet Music from Pique Dame (Tchaikovsky); Polovtsian Dances from Prince Igor (Borodin); Mazurka (Scriabin); Turkish March (Mussorsky). 3.50, See Prague. 5.5, Talk: The Mining Areas of Ostrava. 5.15, See Prague. 5.30, German Transmission: Talk on Astronomy and Talk on Russian Humourists. 6.0, See Prague. 6.10, See Brno. 6.25, See Prague. 6.55, Russian Song Recital. 7.25, See Prague. 8.30, Symphony in G—The Military (Haydn), by the Station Orchestra, conducted by Plichta. 9.0, See Prague. 9.15 (approx.), Close Down.

MOTALA.—See Stockholm.

MUHLACKER.—See Stuttgart.

**MUNICH**

563 kc/s, 533 metres; 1.5 kW. Relayed by Augsburg and Kaiserslautern, 536 kc/s, 560 metres; and Nürnberg, 1,256 kc/s, 239 metres.—3.30 p.m., Orchestral Concert, conducted by Karl List: Overture, Der Bittelstündt (Müllacker); Rondo (Sibelius); Potpourri of Heber Music: Ballad and Polonaise (Vieuxtemps); Lyric Suite (Mauss); Waltz from Der Rastelbinder (Lehár); Spanish Dance from La vida breve (Fallá); Dance (Debussy). 4.45, Talk for Young People. 5.5 (from Nürnberg), Song Recital. 5.25, Review of Books on University Reform. 5.45,

Time, Weather and Market Prices. 6.0, Transmission for all German Stations, relayed from Stuttgart. 7.0, Schach der Eva—Play (Julius Pohl). 8.10, Chamber Music by the Berber Quartet. 9.0, Austria. . . . 9.20, Time, Weather, News and Sports Notes. 10.0, Concert by the Station Orchestra, conducted by Karl List: Overture, Hans Heiling (Marschner); Scherzo from the Symphony in B flat (Sehmann); Viola Concerto (Handel); Allegro for Organ and Strings (Mozart); German Dances (Haydn); The Farewell Symphony (Haydn). 11.30 (approx.), Close Down.

NAPLES.—See Rome.

NOTODDEN.—See Oslo.

**OSLO**

277 kc/s, 1,083 metres; 60 kW. Relayed by Fredriksstad, 815 kc/s, 368.1 metres; Hamar, 522 kc/s, 574.7 metres; Notodden, 671 kc/s, 447.1 metres; Porsgrund, 662 kc/s, 453.1 metres, and Rjukan, 671 kc/s, 447.1 metres, and Jelløy LCL, 6,990 kc/s, 42.92 metres.—4.0 p.m., Concert of Light Music by the Radio Ensemble, conducted by Oscar Gustavson. 5.0, German Lesson. 5.30, Reading. 6.0, Announcements, Weather and News. 6.30, Agricultural Talk. 7.0, Time Signal. 7.1, Concert. Part I—Concerto for Four Pianofortes and String Orchestra (Bach). Chaconne for Violin and Pianoforte (Vitali). Part II—La Serva Padrona—Opera in Two Acts (Pergolesi). 8.10, Political Review. 8.40, Weather and News. 9.0, Topical Talk. 9.15, Variety Programme, relayed from Bodø, 662 kc/s, 453.1 metres.

OSTERSUND.—See Stockholm.

**PALERMO**

556 kc/s, 539.5 metres; 3 kW.—7.0 p.m., Dopplavoro Notes, Tourist Report, Agricultural Notes, Report of the Royal Geographical Society and Giornale Radio. 7.20, Gramophone Music. In the interval at 7.30, Time and Announcements. 7.45, Chamber Music by the Station Quartet and Vincenzo Mannino (Pianoforte); Quartetto in un tempo (Mortari); Sonata in D for Pianoforte and Violin (Beethoven); Sonata for Pianoforte, Violin and Cello (Barbieri); Strimpellata (Castellanovo Tedesco); Melody (Mendelssohn); Scherzo (Manno). 9.0, Gramophone Concert. 10.0, News.

**PARIS**

EIFFEL TOWER, Call FLE, 207.5 kc/s, 1,445.7 metres; 13 kW. Time Signals on 2,650 metres at 9.26 a.m. and 10.26 p.m. (preliminary and 6-dot Signals)—5.45 p.m., Le Journal Parlé. 7.15, Weather. 7.25, News. 7.30, Orchestral Concert, conducted by Flamant: Overture, Hansel and Gretel (Humperdinck); Symphonic Poem, Sur la mer lointaine (Moreau); Selection from Boris Godunov (Mussorsky). 8.0, Political Review. 8.15, Concert (contd.), Five Songs (Maclabey-Ganeval): (a) Le Papillon (Lamartine), (b) O triste, triste (Verlaine), (c) Il pleurt des pétales de fleurs (Samaïn), (d) La vie est une fleur (Samaïn), (e) Femme et chatte (Verlaine); Pagode au crépuscule (Flamant); Wine, Woman and Song (Johann Strauss). 9.0 (approx.), Close Down.

**PARIS**

POSTE PARISIEN, 914 kc/s, 328.2 metres; 60 kW.—7.0 p.m., Gramophone Music: Ballet Music from The Bartered Bride (Smetana); Farandole from L'Arlesienne (Bizet); Empereur Waltz (Joh. Strauss). 7.15, Le Journal Parlé. 7.30, Hot Jazz on Gramophone Records. 8.0, Talk on Aviation. 8.30, Humorous Programme by Max Régnier and his Company. 9.0, Interval. 9.20, Guessing Competition: Who is it? 9.35, Concert, with Gramophone Music. 10.30, News.

**PARIS**

RADIO-PARIS, Call GFR, 174 kc/s, 1,726 metres; 75 kW.—6.45 a.m., Gymnastics. 7.30, Weather and Gymnastics. 7.45, Gramophone Music: Minuet (Boccherini); Liebesfreund (Kreisler); Old Spanish Song (Aubert); Sarabande (Ferroud). 8.0, Press Review and Weather. 12 Noon, Gramophone Records: Extracts from Béatrice (Dandelin); Two Sketches (Devilliers); Two Sketches (Selling); Souvenir (Drda); Two Sketches (Rodor); Le petit malade (Courtel); Eloge de vin (Daudet); Three Sketches (Bach and Laverne). 1.0 p.m., Exchange, News and Weather. 1.5, Concert by Max Francy and his Orchestra. 2.0, Exchange. 3.45, Exchange. 6.20, Agricultural Talk. 6.45, Talk on the Cinema. 7.0, Book Review. 7.20, Gramophone Music: Selection from Dixie Shades (Minevitch); Suzon (Nacio-Herb Brown). 7.30, Popular Concert: Waltz, Veux-tu rêver? (Marey); An Evening at Singapore (Sylviano); Tango, Almagro (Tirarni); Foxtrot, O Tino (Leno). 7.45, News and Agricultural Talk. 8.0, Readings (Zweige). 8.30, News, Sports Notes and Weather. 8.40, Review by Paul Reboux. 8.45, Concert of Chamber Music: Pianoforte and Violin Duet (Rossa); Songs: (a) Three Songs (Chausson), (b) Florentine Serenade (Duparc), (c) Le manoir de Rosamunde (Duparc); Pianoforte Solos: (a) Hommage à Rameau (Debussy), (b) Impromptu No. 3 in A Flat (Faure), (c) Italian Caprice (Poulenc); Three Songs (Fauré): (a) Le parfum impérisable, (b) Soir, (c) Mandoline; Two

Songs (Debussy): (a) Green, (b) Chevaux de bois; Concert for Pianoforte, Violin and String Quartet (Chausson). In the interval at 9.15, Press Review and News.

**PITTSBURGH**

**KDKA**, 989 kc/s, 306 metres; 50 kW. Relayed by **W8XX** on 48.86 metres and 25.27 metres.—7.0 p.m., Musical Originalities, from **New York**, 7.30, **KDKA** Home Forum, 8.0 to 9.30, **New York** Relay, 8.0, Radio Guild, 9.0, Betty and Bob, 9.15, Rhythmic Serenade, 9.30, Business News and Market Reports, 9.45, Words and Music, from **New York**, 10.0, Uncle Tom and Betty, 10.15, **KDKA** Kiddies' Klub, 10.30, The Singing Lady, from **New York**, 10.45, Orphan Annie, from **New York**, 11.0, News-Reeler, Pat Haley, 11.15, Sports and Programme Review, 11.30, Evensong, 11.45 to 12.45 a.m. (Tuesday), **New York** Relay, 11.45, Lowell Thomas, 12 Midnight, Amos n' Andy, 12.15, Baby Rose Marie, 12.30, Potash and Perlmutter, 12.45, What would you do? 1.0, Side Show, from **New York**, 1.30, The Silver Toppers, 1.45 to 3.30, **New York** Relay, 1.45, Red Davis, 2.0, Sinclair Minstrels, 2.30, Melody Moments, 3.0, Popular Programme.

**PORSGRUND**.—See Oslo.

**PRAGUE**

614 kc/s, 488.6 metres; 120 kW.—3.0 p.m., See **Moravska-Ostrava**, 3.50, Programme for Children, 4.5, Talk: The Spirit and Practice of American Schools, 4.15, Gramophone Music, 4.35, Elementary English Lesson, 4.50, Gramophone Music, 5.5, Agricultural Programme, 5.15, Talk for Workers: The International Situation, 5.25, News in German, 5.30, German Transmission, 6.0, Talks, 6.0, Time, News and Weather, 6.10, See **Brno**, 6.25, Concerto for Oboe, Bassoon and Pianoforte (Milde), 6.40, Reading, 6.55, See **Brno**, 7.25, Don Quixote in Music and Literature—Concert by the Station Orchestra, with Commentary: Burlesque, The Knight, with Pianoforte (Finke); Song from Don Quixote (Purcell); Song from Don Sancho (Liszt); Music to Dyk's Don Quixote (Kricka); Symphonic Poem, Don Quixote (R. Strauss); Chaliapine: Song from the Sound Film, Don Quixote (Ibert), on Gramophone Records, 8.30, Sonata in B Minor, for Violin and Pianoforte, Op. 10 (Foster), played by Novák and Solc, 9.0, Time, News and Sports Notes, 9.15, Talk in German: Winter Sports in Bohemia, 9.30 (approx.), Close Down.

**RADIO-SUISSE ROMANDE**

**SOTTENS**, 743 kc/s, 403 metres; 25 kW.; and **Geneva**, 400 kc/s, 749.9 metres.—6.0 to 6.15 a.m. (from **Lausanne**), Gymnastics, 11.28, Time Signal from Neuchâtel Observatory, 11.30, News and Weather, 11.40 (from **Geneva**), Gramophone Concert, 12 Noon (from **Geneva**), Financial Notes, 12.10 p.m. (from **Geneva**), Gramophone Concert (cont'd.), 1.0, Interval, 2.58, Time Signal from Neuchâtel Observatory, 3.0, See **Schweizerischer Landessender**, 4.0, Gramophone Concert of Swiss Choral Music, 4.30, Concert by the Station Orchestra, 5.0 (from **Lausanne**), Book-keeping Lesson, 5.30 (from **Lausanne**), Programme for Children, 5.55 (from **Lausanne**), Italian Lesson, 6.20 (from **Lausanne**), Talk: The Prevention of Motor Accidents, 6.45 (from **Lausanne**), Notes on the Broadcasts for Schools, 6.59 (from **Lausanne**), Weather Report, 7.0 (from **Lausanne**), Song Recital by Mme. Nicod-Burnens, 7.15 (from **Lausanne**), Talk on the following Transmission, 7.30 (from **Lausanne**), Concert by the Station Orchestra, conducted by Ansermet, relayed from the Municipal Theatre, Soloist: Nathan Milstein (Violin). In the interval, News and Weather, 9.30 (approx.), Close Down.

**RJUKAN**.—See Oslo.

**ROME**

Call **IRO**, 680 kc/s, 441 metres; 50 kW. Relayed by **Naples**, 941 kc/s, 319 metres; **Milan** (**Vigentino**), 662 kc/s, 453.1 metres, from 7.45 p.m., and **2RO**, 11,810 kc/s, 25.4 metres.—12 Noon to 1.15 p.m., Gramophone Concert. In the intervals at 12.30, Giornale Radio and Exchange, and at 1.0, Time and Announcements, 3.30, Children's Radio Review, 3.55, Giornale Radio and Exchange, 4.10, Weather Forecast, 4.15, Talk, 4.30, Soprano Song Recital by Laura Pasini, relayed from the Royal Philharmonic Academy, 5.40 (**Naples**), Shipping and Sports Notes, 5.45, Dopplavoro Announcements and Tourist Report, 6.10, Agricultural Notes and Wheat Market Report, 6.20, News in Foreign Languages, 6.40, Giornale Radio, 7.0, Time and Announcements, 7.30, Giornale Radio and Sports Notes, 7.45, Concert of Light Music. In the interval, Talk, 10.0, Giornale Radio.

**SALZBURG**.—See Vienna.

**SCHENECTADY**

**WGY**, 790 kc/s, 379.5 metres; 50 kW. Relayed at intervals by **W2XAF** on 31.48 metres, and by **W2XAD** on 19.56 metres.—7.30 p.m., Revolving Stage, from **New York**, 8.0, Health Hunters, 8.15 to 8.30 (approx.), Soloist, from **New York**, 12.45 a.m. (Tuesday), Stock Reports, 1.0 to 4.0, **New York** Relay, 1.0, Soconyland Sketch, 1.30, String Symphony, 2.0, A. and P. Gipsies, 2.30,

NOV. 27th **MONDAY** continued

Popular Programme, 3.0, Variety Programme, 3.30, Drama K-7, 4.0, Programme Resumé.

**SCHWEIZERISCHER LANDESENDER**

**BEROMUNSTER**, 653 kc/s, 459 metres; 60 kW.; **Basle**, 1,229 kc/s, 244.1 metres, and **Berne**, 1,220 kc/s, 245.9 metres.—5.50 a.m. (from **Zürich**), Skiing Lesson, 6.5, Interval, 9.20 (from **Basle**), Broadcast for Schools—A Musical Journey through Europe, 9.50, Interval, 11.0 (from **Basle**), Round the World—Gramophone Concert, 11.29, Time Signal from Neuchâtel Observatory, 11.40 (from **Basle**), Gramophone Concert (cont'd.), 12.25 p.m. (from **Basle**), Time, Weather and Exchange, 2.30 (from **Basle**), Dance Music on Gramophone Records, 3.0 (from **Basle**), Concert of Chamber Music by the Radio Quintet, 4.0, Swiss Songs for Choir (on gramophone Records), 4.30, Light Music by the Station Orchestra, 5.0 (from **Basle**), Songs by a Children's Choir, 5.30 (from **Zürich**), Talk in Dialect, 6.0, Time and Weather, 6.5 (from **Zürich**), Gramophone Concert, 6.20 (from **Zürich**), Elementary English Lesson, 6.50 (from **Zürich**), Fifth Subscription Concert, relayed from the Tonhalle. In the interval at 8.0 (approx.), Weather and News. After the Concert, Dance Music on Gramophone Records, 9.15 (approx.), Close Down.

**SOTTENS**.—See Radio-Suisse Romande.

**STOCKHOLM**

689 kc/s, 436 metres; 55 kW. Relayed by **Boden**, 242 kc/s, 1,239.5 metres; **Göteborg**, 932 kc/s, 322 metres; **Hörby**, 1,167 kc/s, 257

Suite in D Minor (Erb); Two Melodies (Erb): (a) Berceuse, (b) La barque; Menuet galant (Erb); Ronde de nuit (Erb); Two Melodies (Gross): (a) Cette petite, (b) D'r Hans; Scènes foraines dans un village d'Alsace (Klein); Two Melodies (Gross): (a) Fileuse, (b) Berceuse; Two Pieces for Orchestra (Schürli): (a) Pastorale, (b) Fileuse; A la Source du Mont Sainte-Odile (Schürli); Two Melodies (North); Asiatic Suite for Orchestra (Pohl); Sextet for Strings (Adam). In the interval at 9.30, Press Review in French, 10.30 (approx.), Close Down.

**STUTTGART**

**MUHLACKER**, 832 kc/s, 360.5 metres; 1.5 kW. Relayed by **Freiburg**, 527 kc/s, 570 metres.—12.25 p.m., Local News and Weather, 12.35 p.m., Gramophone Records of the Vienna Philharmonic Orchestra and Paul Bender (Songs), Kaisermarsch (Wagner); Song: Der Erlkönig (Loewe); Scherzo from the Fourth Symphony, in E flat (Bruckner); Song: Edward (Loewe); Suite from Der Rosenkavalier (Richard Strauss); Song: Wedding Song (Loewe); Leiches Blut (Joh. Strauss); Sphärenklänge (Jos. Strauss); Song: Tom der Reimer (Loewe); Annen-Polka (Joh. Strauss); March from The Gipsy Baron (Joh. Strauss), 1.30 to 2.30, Interval, 2.30, Talk: The Lüneburger Heide, 3.0, See **Frankfurt**, 5.0, French Lesson, 5.20, Technical Talk, 5.35, Ready Reckoning Lesson, 5.50, Time, Agricultural Notes and Weather, 6.0, Transmission for all German Stations: First Act of the Valkyrie—Opera (Wagner), 7.0 to 9.0, See **Frankfurt**, 9.0, Time and News, 9.20, Topical Talk, 9.30, Local News, Weather and Sports Notes.

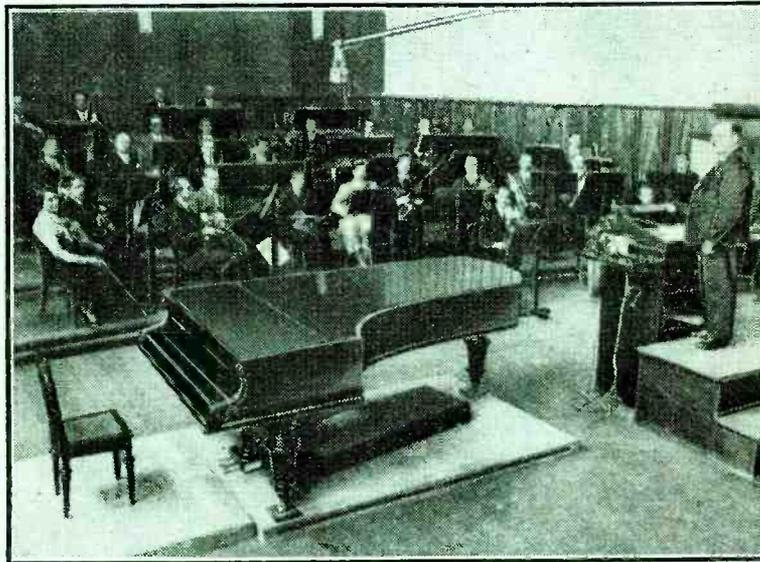

**SWISS FAVOURITES.** The well-known orchestra at the Zurich studio, from which performances are broadcast through Schweizerischer Landessender (Beromunster).

metres; **Motala**, 222.5 kc/s, 1,348 metres; **Ostersund**, 402 kc/s, 746.2 metres, and **Sundsvall**, 554 kc/s, 542 metres.—12 Noon to 12.35 p.m., Broadcast for Schools, 4.5, Provincial Programme, relayed from **Falun**, 977 kc/s, 307 metres, 4.25, Reading, 4.45, Gramophone Music, 5.45, Elementary German Lesson, 6.15, Weather and News, 6.30, Astronomical Talk: The Milky Way, relayed from **Malmö**, 1,301 kc/s, 230.6 metres, 7.0, String Quartet in D, Op. 11 (Tchaikovsky) by the Danish Quartet, 7.35, Talk, 7.50, Variety Programme, 8.20, Talk, 8.45, Weather and News, 9.0, Report by a Night Worker, followed by Orchestral Music,

**STRASBOURG**

869 kc/s, 345 metres; 11.5 kW.—11.30 a.m., Gramophone Records, 12.45 p.m., News, Time and Exchange, 1.5, Light Music on Gramophone Records, 2.0, Interval, 5.0, Orchestral Concert, conducted by Roskam: March, Dawn of Freedom (Lotter); A bâtons rompus (Gillet); Waltz, Un jour à Seville (Waldteufel); Esquisses flamandes (Brisselmans); Overture, Les petites Michus (Messenger); Selection from Le châtelet (Adam); Cello Solo: Rêve (d'Ambrosio); March, The Grand Victory (Savasta), 6.0, Fortnightly Review of Literature, 6.15, Topical Talk in German, 6.30, Gramophone Concert, 7.30, Time and News, 7.45, Gramophone Music, 8.0, Press Review in German and Lottery Results, 8.30, Concert of Alsatian Music by the Station Orchestra and Soloists. Conductor, Maurice de Villars,

9.45, Gramophone Music, 10.0, See **Leipzig**, 11.0, See **Langenberg**, 12 Midnight (approx.), Close Down.

**SUNDSVALL**.—See Stockholm.

**TOULOUSE**

779 kc/s, 385 metres; 8 kW.—6.0 p.m., News, 6.15, Accordion Solos, 6.30, Chansonnettes, 6.45, Operetta Music: Selection from The Dollar Princess (Fall); Selection from Les noces de Jeannette (Massé); Aria from Kadubec (Yvain), 7.0, Music from Sound Films, 7.15, News, 7.30, Violin Recital: Old Viennese Waltz (Kreisler); Die Biene (Schubert); Spanish Dance (Granados); Roses of Picardy (Haydn Wood), 7.45, Opera Music: Arias from Marouf (Rahaud); Sappho (Massenet), Le roi malgré lui (Chabrier), and Romeo and Juliet (Gounod), 8.0, Light Music, 8.15, Music by an Argentine Band, 8.30, Military Music, 8.45, Opera Music: Micaëla's Aria from Carmen (Bizet); Prayer from William Tell (Rossini); Aria from Les Huguenots (Meyerbeer); Aria from Messaline (de Lara), 9.0, Concert by the Station Orchestra, conducted by Espy: Overture, A Festival in Aranjuez (Demersmann); Alsatian Dances (Levadé); Selection from La Haut (Yvain); Waltz, Wienerbül (Strauss); Selection from La Bohème (Puccini); Reverie d'un soir, and Marche militaire from Suite algérienne (Saint-Saëns). In the interval, Light Music, 10.15, News, 10.30, Programme for Listeners in Morocco. Part I—Songs, Part II—Hawaiian Guitar Music, 10.50,

Tourist Talk, 11.0, Request Music, 11.15, Dance Music, 12 Midnight, News and Weather, 12.5 a.m. (Tuesday), Operetta Music: Arias from Le postillon de Longjumeau (Adam); Le Comte Obligado (Moretti), and Elle est à vous (Yvain), 12.15, Orchestral Music: Overture, Semiramis (Rossini); Ballet égyptien (Luigini), 12.30 (approx.), Close Down.

**TRIESTE**

1,211 kc/s, 247.7 metres; 10 kW.—4.10 p.m., till Close Down, See **Turin**.

**TRONDHEIM**.—See Oslo.

**TURIN**

1,096 kc/s, 273.7 metres; 7 kW. Relayed by **Milan**, 903 kc/s, 332.2 metres; **Genoa**, 959 kc/s, 312.8 metres, and **Florence**, 598 kc/s, 501.6 metres.—4.10 p.m., Orchestral Concert, conducted by Tito Petralia, 5.0 to 5.5, Weather, 5.40, Giornale Radio, Dopplavoro Announcements and Gramophone Music, 6.0, Time, Tourist Report and Gramophone Music, 6.10, Wheat Market Report, 6.20, News in Foreign Languages, 6.40, Gramophone Music, 7.0, Announcements, Giornale Radio and Weather, 7.15, Request Programme, 8.15, A Play in One Act, 8.45, Concert of Chamber Music, 9.30, Dance Music on Gramophone Records, 10.0, Giornale Radio.

**VATICAN CITY**

15,120 kc/s, 19.84 metres (Morning), and 5,969 kc/s, 50.26 metres (Evening); 10 kW.—10.0 to 10.15 a.m., Religious Information in Italian, 7.0 to 7.15 p.m., Religious Information in Italian.

**VIENNA**

580 kc/s, 517.2 metres; 100 kW. Relayed by **Craz**, 852 kc/s, 352.1 metres; **Innsbruck**, 1,058 kc/s, 283 metres; **Klagenfurt**, 662 kc/s, 453.1 metres; **Linz**, 1,220 kc/s, 245.9 metres; and **Salzburg**, 1,373 kc/s, 218.5 metres.—10.30 a.m., Concert by the Wiener Symphoniker, conducted by Josef Holzer. Overture, Irrfahrt uns (Glück) (Suppé); Waltz from Fas Fürstentkind (Lehar); Deutsche Marschpieren (Blanckenburg); Suite (O. Wagner); Waltz, Donauweibchen (Joh. Strauss); Romance for Bugle Horn (Landl); Gavotte (Czibulka); Nur ein Lied und ein Mädel aus Wien (Schieder); Humoresque (Blayer-Aichhorn); Violin Solo: Meditation (Glazunov); Selection from Folenblut (Nedbal). In the interval at 10.53, Weather, 12 Noon, Time, News and Programme Announcements, 12.10 to 1.0 p.m., Gramophone Records, 2.0, Time, Weather and Exchange, 2.15, Talk: Clean Milk, 2.25, Pianoforte Sonata in F (Mozart), by Lili Gutovskiy and Gertrud Zerner, 2.50, Sound Film Music on Gramophone Records, 3.35, Talk: Schloss Kreuzenstein and its History, 4.0, Talk: Great Composers and Singers of the last Thirty Years, 4.25, Soprano and Cello Recital by Molly Jonas and Richard Krottschak, 5.5, Talk: Theatrical Review, 5.25, Talk: Books and Works of Reference in connection with the Week's Talks, 5.30, Elementary English Lesson, 6.0, Concert by the Wiener Symphoniker, conducted by Philipp de la Cerdà. Overture, Semiramis (Rossini); Bilder aus dem Osten (Schumann); Ballet Music from The Queen of Sheba (Gounod); Entry March from The Queen of Sheba (Goldmark); Suite, Aus dem Morgenlande (Heuberger); Selection from Hérodiade (Massenet). In the interval at 6.35, Time, Weather and Programme Announcements, 7.15, Topical Programme, 7.30, Austrian Folk Music—Wireless Potpourri (Riedinger). The Wiener Symphoniker, conducted by Josef Holzer, the Vienna Boys' Choir, and Soloists, 8.45, News, 9.0, Gramophone Concert, followed by Announcements.

**WARSAW**

212.5 kc/s, 1,411 metres; 120 kW.—10.57 a.m., Time Signal and Fanfare from the Tower of St. Mary's Church, Cracow, 11.5, Wagner Music on Gramophone Records, 11.30, Radio Journal, 11.35, Weather, 11.38, Gramophone Music, 12 Noon, Interval, 2.25, Announcements, 2.40, Report for Boy Scouts, 2.45, Aviation Report and Anti-Gas Drill, 2.55, Songs on Gramophone Records, 3.40, Elementary French Lesson, 3.55, Concert by the Bulin Quintet, 4.50, Agricultural Correspondence, 5.0, Talk: Problems of National Culture, 5.20, Pianoforte Recital by Helene Ottaw: Sicilienne (Respighi); Passacaglia (Roncalli-Respighi); Etude in A flat, Op. 25 (Chopin); Etude in G sharp minor, Op. 25 (Chopin); Gretchen am Spinnrad (Schubert-Liszt); Spinning Song from The Flying Dutchman (Wagner); L'île joyeuse (Debussy); Toccata (Debussy), 6.0, Programme Announcements, 6.25, Talk relayed from **Cracow**, 959 kc/s, 312.8 metres, 6.40, Sports Notes, 6.47, Radio Journal, 7.0, Concert by the Station Orchestra, conducted by Nawrot. Soloist: Olga Saumska (Songs), Overture, Banditenstrieche (Suppé); Andalusian Nocturne (Infante); Waltz (Joh. Strauss); Four Songs; Serenade (Suk); Ballet Suite (Gyldmark); Melody (Milhaud); Harvesters (Powiadowsky); Three Songs; Roses d'hiver (Waldteufel); Polonaise (Lewak); March on Themes from Carmen (Bizet). In the interval at 8.0, Talk, 9.0, Dance Music, relayed from the Gastronomica Café, 10.0, Aviation Weather Report and Police Notes, 10.5, Dance Music (cont'd.).

**ZÜRICH**.—See Schweizerischer Landessender.

## ATHLONE

725 kc/s, 413 metres; 60 kW. Relayed by Dublin, 1,382 kc/s, 217 metres, and Cork, 1,337 kc/s, 224 metres.—1.30 to 2.30 p.m., Time Signal, Weather Report, Stock Report and Gramophone Concert. 5.0, Programme for Children. 5.40, News. 7.0, Gaelic Reading. 7.15, Talk. 7.30, Time Signal. 7.31, Flute and Harp Duets by Mollie Flynn and A. Fagan. 7.55, Mezzo-Soprano Solos by Cecily Kenny. 8.10, The Station Orchestra. 8.45, Violin Solos by Nora Richardson. 9.0, Lecture Recital by Grace O'Brien. 9.30 to 10.30, Programme by the I.B.C. (Ireland), Ltd. 9.30, Military Band Music: Signature Tune: Choo Choo (Malneo); March, The Entry of the Gladiators (Fucik); Prælude (Jarnefeld); The Bells of St. Malo (Rimmer); The Wedding of the Rose (Jessel); Signature Tune: Choo Choo. 9.45, Concert of Dance Music: In the Park in Páree; When Work is through; The Shadow Waltz, Mississippi Basin. 10.0, Concert arranged by the International Broadcasting Company (Ireland), Ltd. Dance Music: Dixie Doorway; That's my Home; I give my Heart; Racing Commentary; She's my Pet; I can't remember; Shuffle off to Buffalo; You're getting to be a habit with me; Carolina Lullaby. 10.30, I.B.C. Good-night Melody, followed by News and Weather. 10.40, Pipe and Fiddle Duets by L. Rowsome and M. Dunne. 11.0 (approx.), Close Down.

## BARCELONA

EAJ1, 858 kc/s, 349.6 metres; 8 kW.—6.0 p.m., Trio Concert: Minuet No. 2 in G (Beethoven); Extase (Ganne); Selection from The Twilight of the Gods (Wagner); Serenata (Rachmaninov); Symphonic Entr'acte (Desprez); Masette (Colin); Selection from The Pearl Fishers (Bizet). 7.0, Request Gramophone Records. 7.30, Exchange and Talk in Catalan. 8.0, Gramophone Music. 8.30, Educational Programme: Geography and History Lesson, followed by News. 9.0, Chimes from the Cathedral. Weather, Messages to Seamen, Exchange and Market Prices. 9.5, Sponsored Programme. 9.30, Part Relay of an Opera from the Gran Teatro del Liceo. In the interval at 11.0, News.

## BARI

1,112 kc/s, 269.8 metres; 20 kW.—3.30 p.m., Quintet Concert. 3.55 (approx.) to 7.0, See Rome. 7.0, News in Albanian. 7.15 till Close Down, See Rome.

BASLE.—See Schweizerischer Landessender.

## BELGRADE

698 kc/s, 429.7 metres; 2.8 kW.—6.0 p.m., Opera Arias by Paul Freilich. 6.30, Talk. 7.10, Quartet (Smetana). 7.50, Talk. 8.0, Popular Albanian Songs. 9.0, Time and News. 9.15 (approx.), Concert by the Station Orchestra.

## BERLIN

DEUTSCHLANDSENDER (Reichssender), 183.5 kc/s, 1,635 metres; 60 kW.—1.0 p.m., Gramophone Concert. Ständchen (Schubert); Wiegenlied (Mozart); Der Vogel im Walde (Taubert); An die Musik (Schubert); Mäandnacht (Schumann); Ich liebe Dich (Beethoven); Guten Abend, gute Nacht (Brahms); Die Liebe sass als Nachtigall (Kau); Maria sitzt am Rosenhag (Reger); Auf dem Wasser zu singen (Schubert); Sandmännchen (Brahms); O komm im Traum (Liszt); An die Geliebte (Wolf); Sehnsucht nach dem Frühling (Mozart); Liebesbotschaft (Schubert). 2.0, Talk for Country Women. 2.15, Talk: The German Woman's Right to Work. 2.30, Weather and Exchange. 2.45, Talk on the History of Flying: Daedalus and Icarus. 3.0, See Langenberg. 4.0, Handwork for Children. 4.20, Variety Programme. 5.0, Poems. 5.5, Realizing. 5.25, Political Press Review. 5.45, Weather and News. 6.0, Transmission for all German Stations: Der ewige Bauer—Radio Play—(Josef Martin Bauer), with Music by Rudolf Wagner-Regeny. 7.0, Talk by Dr. Paul Fleischer: German Workers in the Struggle for Germany's Equality as a Nation. 7.10, The Day's Motto. 7.15, See Berlin (Funkstunde). 8.10, Report of the Laying of the Foundation Stone of the Kurmark Open Air Theatre on Gross-Glienicker Lake (on Gramophone Records). 9.0, Weather, News and Sports Notes. 9.45, Weather. 10.0, Concert from Hamburg. 11.0 (approx.) Close Down.

## BERLIN

FUNKSTUNDE, 716 kc/s, 419 metres; 1.5 kW. Relayed by Zeesen, DJC, DJA, DJD, DJB, and DJE.—2.20 p.m., Chamber Music Concert on Gramophone Records: Pianoforte Solo, Die Quelle (Schmalstich); Violin Solos: (a) Melody (Glück), (b) Canonetta (d'Ambrosio); Cello Solos: (a) Wiegenlied (Klengel), (b) Scherzo (Klengel); Pianoforte Solos: (a) Malagueña (Albeniz), (b) Seguidilla (Albeniz). 2.45, Talk on Sport for Young People. 3.0, Schubert Song Recital (on Gramophone Records): Das Rosenband; Der Musesohn; Am Bach im Frühling; Mein. 3.15, Talk: The Wonders of Nature. 3.30, Concert from Langenberg. 4.30, Radio Picture about Johann Gottfried Seume (Wolfgang Weyrauch). 5.0, Review of Books. 5.30, The Funkstunde informs its Listeners.

TUESDAY  
NOVEMBER THE TWENTY-EIGHTH

5.45, Topical Talk. 6.0, Transmission for all German Stations, relayed from Berlin (Deutschlandsender). 7.0, See Berlin (Deutschlandsender). 7.10, Announcements. 7.15, Symphony in C, No. 7 (Schubert) by the Berlin Wireless Orchestra, conducted by Eugen Jochum. 8.5, Between Evening and Night—Reading of November Poems. 8.15, Septet in E flat, Op. 20 (Beethoven). 9.0, News. 9.20, See Hamburg. 11.0 (approx.), Close Down.

BERNE.—See Schweizerischer Landessender.

BEROMÜNSTER.—See Schweizerischer Landessender.

BODEN.—See Stockholm.

BODO.—See Oslo.

## BRATISLAVA

1,073 kc/s, 279.5 metres; 14 kW.—3.0 p.m., Concert by the Station Orchestra. 3.55, Programme from Brno. 4.15, See Prague. 4.35, Talk. 4.50, Chopin Pianoforte Recital by Vilem Pistelek: Scherzo, Op. 31; Fantasia Impromptu, Op. 66. 5.10, Educational Talk: Experiences of a Lecturer. 5.40, Lesson in Telegraphy. 5.55, Hints for Housewives. 6.0, See Prague. 6.30, Concert by the Station Orchestra. 7.0, See Brno. 9.0, See Prague. 10.0 (approx.), Close Down.

BREMEN.—See Hamburg.

## BRESLAU

923 kc/s, 325 metres; 60 kW. Relayed by Gleiwitz, 1,185 kc/s, 253.1 metres.—11.5 a.m., Concert by the Silesian Philharmonic Orchestra, conducted by Behr: Overture, Anacreon (Cherubini); Cassation No. 1 (Mozart); Five German Dances (Schubert); Overture, Preciosa (Weber); Wedding Music (Jensen); Styrian Dances (Lanner); Overture, Semirams (Rossini); Elegy and Waltz from Op. 48 (Tchaikovsky); Mazurka, Lob der Frauen (Strauss). In the interval at 12.45 p.m., Time, Weather, News, and Exchange. 1.40, Programme arranged by the Post Office, with Gramophone Records. 2.0, Agricultural Prices. 2.20, Listen, Everybody! 2.30, Programme for Children. 3.0 (from Gleiwitz), Concert of Light Music, relayed from the Ilus Oberschlesien. 4.30, Agricultural Prices. 4.35, Talk: The Religious Tendencies of Contemporary German Youth. 5.0, Talk: Peasant Colonisation—its History and its Aims. 5.20, Programme to be announced. 5.40, Programme Announcements and Meat Market Report. 6.0, Transmission for all German Stations, relayed from Berlin (Deutschlandsender). 7.0, See Berlin (Deutschlandsender). 7.10, Request Concert by the Station Orchestra, conducted by Popitz. Soloist: Helmut Hellendorf (Tenor). 8.20, News. 8.25, Hermann Löns—Radio Pictures from the Author's Life and Work (Kauptert). 9.15, Time, Weather, and Announcements. 9.40, Political Press Review. 10.0, Die Liebe, ja die Liebe—Cabaret on Gramophone Records (arr. Odda). 11.0 (approx.), Close Down.

## BRNO

878 kc/s, 342 metres; 35 kW.—5.25 p.m., German Transmission: News, Talk on Cuba and Agricultural Report. 6.0, See Prague. 6.30, Saxophone Solos. 6.45, A Report from a Hospital in Brno. 7.0, The Mikado—Comic Opera in Two Acts (Sullivan). 9.0, See Prague. 10.0 (approx.), Close Down.

## BRUSSELS (No. 1)

I.N.R., 589 kc/s, 509.2 metres; 15 kW.—12 Noon, Concert by the Small Station Orchestra, conducted by Leemans: Danse des enfants (Honegger); Sérénade à Mabel (Godard); Solitude de Pierrot (Messager); Intermezzo (Mussorgsky). 12.20 p.m., Pianoforte Recital by Sophie Tuyns: St. François de Paul (Liszt); Toccata (Saint-Saëns); L'île joyeuse (Debussy). 12.40, Orchestral Concert (contd.): Romance sans paroles, Op. 17 (Fauré); Ton nom (Holmès); Parmi les roses (Nérini); Elegy (Rachmaninov); Idyll (Cassado). 1.0, Le Journal Parlé. 1.10, Gramophone Music; Part I: Extracts from Sound Films; Part II: Opera Music. 1.45, Selection from Don Juan (R. Strauss), on Gramophone Records. 5.0, Concert of Belgian Music by the Radio Orchestra, conducted by Franz André: Suite pastorale (Vreuls); Nocturne (Daneau); Russian Rhapsody (Leemans). 5.30, Programme for Children. 6.5, Talk. 6.15, Sonata for Cello and Pianoforte (Harsanyi), by Hans Kindler (Cello) and the Composer. 6.30, Concert by the Small Station Orchestra, conducted by Leemans: Passe-pied Henry II (Balleron); Sixteenth Century Rondeau (Nérini); Ballet Louis XIV (Pouget); Suite of Scottish Airs (Gilsou). 7.15, Review of the Week. 7.30, Programme for Women and Art Review. 8.0, Concert by the Radio Orchestra, conducted by Franz

André: Good Night Mr. Nightingale (Polack); I can't remember (Berlin); Rhapsody in Blue (Gershwin); In the Valley of the Moon (Tobias); Jumpin' up and down (Confrey); Butterflies in the Rain (Warren); Let's all sing like the Birdies sing (Evans). 8.45, Educational Talk. 9.0, Concert by the Station Symphony Orchestra, conducted by Kumps; Soloist, Danielle Claes (Songs): Overture, Si j'étais roi (Adam); Aria from Hamlet (Thomas); Ballet Music from Le Cid (Massenet); Overture, William Tell (Rossini); Aria from Madame Butterfly (Puccini); Prélude, Sicilienne and Intermezzo from Cavalleria Rusticana (Mascagni). 9.45, Fauré Song Recital by Danielle Claes: Fleur jetée; Tristesse; Notre amour. 9.55, Christus vincit (Liszt). 10.0, Le Journal Parlé.

## BRUSSELS (No. 2)

N.I.R., 888 kc/s, 337.8 metres; 15 kW. Programme in Flemish.—12 Noon, Gramophone Concert. 1.0 p.m., Le Journal Parlé. 1.10, Concert by the Small Station Orchestra, conducted by Pierre Leemans: March (Myddleton); Overture, Banditenstreich (Suppe); Bonheur capricieux (Bürger); Selection from The Gipsy Princess (Kálmán); Gramophone Records: Slav Dance No. 5 (Dvorak); Tango, Frasquita (Coppola); Valse d'amour (Heymann); Pasodoble, Viva Palma (Brockler). 5.0, Concert by the Symphony Orchestra, conducted by Jean Kumps: Overture, Charlotte Corday (Benoit); The Unfinished Symphony (Schubert); Two Songs on Gramophone Records; Slav Dance (Chabrier); Fantasia No. 3 (Benoit-Broeckx); Waltz from Der Rosenkavalier (R. Strauss); Tarantella (Cui). 5.45, Programme for Children. 6.30, Gramophone Records: Selection from (a) Ball at the Savoy (Abraham) and (b) Viktoria and her Hussar (Abraham); Waltz, Parla (Arditi); La campanera (Arditi); Selection from White Horse Inn (Benatzky). 7.0, Gramophone Records of Richard Tauber: Lorelei (Sülicher); Five Songs from the Cycle Dichterliebe (Schumann). 7.15, Talk: Is Democracy Doomed? 7.30, Le Journal Parlé. 8.0, Karel Albert Concert by the Symphony Orchestra, conducted by Jean Kumps: Soloist, Jef Van Schoeland (Songs); Intermezzo, De wilde jacht, from Thyl; Two Songs: (a) Wij hebben geen geld, (b) Het lied van den smid; Suite Beeldenspel. 9.0 (approx.), Dramatic Programme. 9.15, Concert by the Radio Orchestra, conducted by Franz André: Soloist, Jef Van Schoeland (Songs); Overture, The Merry Wives of Windsor (Nicolaï); Nocturne (Chopin); Songs: (a) Tom the Blymer (Loewe); (b) Kamerad (Jef Van Hoof); Extase (Ganne); Bassoon Solo: Der alte Brumbar (Fucik); Xylophone Solo: Verbiage (Foutras); Song (Eysler); Wir marschieren (Doutiez). 10.0, Le Journal Parlé.

## BUCHAREST

761 kc/s, 394 metres; 12 kW.—4.0 p.m., Concert of Variety Music by the Gica Ionesco Orchestra. In the interval at 5.0, Radio Journal. 6.0, Educational Talk. 6.20, Gramophone Music. 6.45, Talk. 7.0, Song Recital by Lya Popovici-Vergu: Reverie (Hahn); May (Hahn); Vorrei (Tosti); Aria from Manon (Massenet); Aria from Frasquita (Lehár). 7.20, Symphony Concert by the Station Orchestra, conducted by Georgezco; Soloist, Mile. Chelaru-Serbesco (Pianoforte); Symphony in D (Haydn); Pianoforte Concerto (Rachmaninov); Symphony No. 1 (Beethoven). In the interval at 8.0, Talk. 8.45, Radio Journal.

## BUDAPEST

545 kc/s, 550.5 metres; 18.5 kW. Also relayed on 840 metres from 6.30 p.m. till Close Down.—4.0 p.m., Dance Music from the Hotel Britannia. 5.0, French Lesson. 5.25, Cello Recital by Nicholas Zsambeki. 6.0, Reading. 6.30, Talk, with Gramophone Illustrations: An Hour in Italy. 7.30, News. 7.45, Organ and Song Recital by Ludwig Akom and Gizella Rituper, relayed from the Academy of Music: Prelude and Fugue in D (Bach); Benedicite (Reger); Pastorale (Scarlatti); Three Songs: (a) Ave Maria, from Otello (Verdi), (b) La Procession (Franck), (c) Ah Perfido (Beethoven); Symphony No. 6 for Organ (Widor); Wolken wandern (Antalfy); Toccata (Barie); Berceuse (Pierné); Dance of the Fairies (Bonnet); Songs: (a) Lied (Bach), (b) Spring Song (Mendelssohn), (c) Aria from Tannhäuser (Wagner); Scherzo (Bossi). 9.30, Weather. 9.40 (approx.), Concert of Gypsy Music from the Café Metro-pole.

CASSEL.—See Frankfurt.

## COPENHAGEN

1,067 kc/s, 281 metres; 0.75 kW. Relayed by Kalundborg, 260 kc/s, 1,153.8 metres, and Skamlebaek OXY, 49.4 metres; 0.5 kW.—

11.0 a.m., Time Signal and Chimes from the Town Hall. 11.2 Concert by the A. Bendix String Ensemble, relayed from the Wivex Restaurant. 1.0 p.m., Interval. 1.40, Concert by the Radio Orchestra, conducted by Launy Gröndahl: Soloist: Else Aumentorp (Songs); March: Folies bergère (Lincke); Overture, Gustave III (Auber); Indian Intermezzo (Morena); Selection from The Little Dutch Girl (Kálmán); Marche lorraine (Ganne); Overture, Isabella (Suppe); Two Old Danish Folk Melodies (Alfred Strandqvist); Waltz, Blondes ou brunes (Ganne); Extracts from Gurre (Holvorsen); Arabesque No. 2 in G (Debussy); Mazurka from Halka (Moniuszko). In an interval at 3.30 (approx.), Danish Folk Songs. 3.40, Programme for Children. 4.30, Exchange and Fish Market Prices. 4.45, Talk. 5.15, Elementary German Lesson. 5.45, Weather. 5.54, Announcements. 6.0, News. 6.15, Time Signal. 6.30, Talk. 7.0, Time Signal from the Town Hall. 7.1, Missionary Society Jubilee Programme, relayed from Veie. 8.10, Gramophone Records of Famous Artists. 8.30, A Visit with the Microphone to a Bookseller's. 9.0, News. 9.15, Concert of Italian Music by the Radio Orchestra, conducted by Fritz Mahler: Suite No. 1, Antiche Danze ed Arie (Respighi); Serenade for Small Orchestra (Casella). 10.0, Dance Music, relayed from the Ludberg Restaurant. In an interval at 11.0, Time Signal and Chimes from the Town Hall. 11.30 (approx.), Close Down.

CORK.—See Athlone.

DANZIG.—See Heilsberg.

DRESDEN.—See Leipzig.

## FECAMP

1,328 kc/s, 225.9 metres; 10 kW.—10.30 a.m. to 12 Noon, Programme in English by the I.B.C. 10.30, Concert: Signature Tune, It beats as it sweeps as it cleans; The Teddy Bears' Picnic (Bratton); I want to be happy, from No. No. Nanette (Youmans); Stormy Weather (Arlen); Veterans of Variety; The Wedding of Mr. Mickey Mouse (Pola); Try a little tenderness (Woods); You're getting to be a habit with me (Dubin); Oh, Johanna (Lawrence); Signature Tune. 11.0, Happy Hour. Part I, Military Music: Signature Tune; Jolly Fellows (Volstedt); La Bénédiction des Poignards (Meyerbeer); March (Alohr); Waltz, Les Sirènes (Waldteufel); The Doge's March (Rosse); Cupid's Army (Sievier); Selection from The Miracle (Humperdinck); Here, there and everywhere (Bosc). Part II, Dance Music: The Wedding of Mr. Mickey Mouse; Cecilia Mia; Tick, Tock; Dinner at Eight; Adios, Goodbye; Oh, Johanna; Shadows in the Swanee; My Moonlight Madonna; Signature Tune. 12 Noon, Programme in French. 3.30 to 6.0, Programme in English by the I.B.C. 3.30, Light Music: The Brooklyn Cakewalk (Thurban); In a Clock Store (Orth); Siboney (Lecuna); Pianoforte Selection, Words and Music (Coward); Happy Darkies (Godfrey); Gipsy Moon (Borganov); Baby, won't you please come home? The Musical Clock of Madame Pompadour (Noack). 4.0, Dance Music: Signature Tune, The Bells of Normandy; Who's afraid of the big bad Wolf? About this time next week; My Moonlight Madonna; Tick, Tock; The Last Round Up; Let the World go drifting by; The Cage in the Window; Don't blame me; Signature Tune. 4.30, I.B.C. Nursery Corner; Birthday Greetings; Trumpets. 4.40, Torquay and Exeter Concert of Operatic Music: Signature Tune, The Night by the Sea; Prelude to Carmen (Bizet); Barcelona from the Tales of Hoffmann (Offenbach); O Star of Eve, from Tannhäuser (Wagner); Selection from Cavalleria rusticana (Mascagni); Anvil Chorus from Il Trovatore (Verdi); The Stars were shining, from Tosca (Puccini); Selection from Faust (Gounod); Prize Song, from The Mastersingers (Wagner); Selection from I Pagliacci (Leoncavallo); One Fine Day, from Madame Butterfly (Puccini). 5.20, Plymouth and Devonport Concert of Light Music: March, La Czarine (Ganne); The Clatter of the Clogs (Flynn); My Hero, from The Chocolate Soldier (Oscar Straus); Pianoforte Selection, He wanted Adventure; Song, Reflections in the Water (Loeb); The Dance of the Nymphs (Birch); A Charming Episode (Ormandy); Signature Tune. 5.45, Concert: Put on your old grey bonnet (Wenrich); Solitary (Burl); Sophisticated Lady (Ellington); I bring a song (Young). 6.0, Programme in French. 10.0 (approx.) till Close Down, Programme in English by the I.B.C. 10.0 (approx.), I.B.C. Members' Request Hour: Selection, The Maid of the Mountains (Fraser-Simson); The Rangers' Song; Indian Love Call, from Rose Marie (Friml); Moonstruck (Coslow); Lay your head on my shoulder (Conrad); Destiny Waltz (Baynes); Learn to croon (Coslow); The Dance of the Cuckoos. 10.30, Dance Music: Signature Tune Bells of Normandy; Let's make Up; Ding, Dong, Ding; Zigeuner, you have stolen my heart; Moths around the candle flame; It's the Talk of the Town; Reflections in the Water; Lazybones; Let's call it a Day; Signature Tune. 11.0, Talkie Time—Times from the Talkies and Shows; Signature Tune, Sittin' in the Dark; Selection, Music in the Air; Vilja Song, from The Merry Widow (Lehár); A Glass of Golden Bubbles (Strauss); I've got you on my mind (Porter); I've found the right girl

NOV. 28th **TUESDAY** continued

(Lupino); A girl like Nina (Abraham); Butterfly Song, from Waltz Time (Strauss); She's everybody's sweetheart now (Hargreaves); Signature Tune. 11.30, Concert by the International Broadcasting Company (Ireland) Ltd.; Signature Tune, Come back to Erin; The Fortune Teller (Herbert); Evolution of Dixie (Lake); Fairy Tales of Ireland (Coates); Singing a song to the Stars (Meyer); Selection from Nalla (Delibes); Irish Song Medley; Southern Rhapsody (Hosmer); The Way to the Heart (Lincke); Signature Tune, Come back to Erin. 12.5 a.m. (Wednesday), News Bulletin in English. 12.10 (approx.), Club Concert for Crickhowell Listeners: Signature Tune, The Chum Song; Oh, Johanna (Lawrence); La Cumparsita (Rodriguez); Sundown in a Little Green Hollow (Whiting); I'll show you off (Abraham); My Kingdom for a smile from you (Kling); Happy as the day is long (Koehler); I've got to get up and go to work (Hupfeld); Passion Flower (Kennedy); If I had someone to love (Hill); Dear Stranger (Hansen); Dancing Butterfly (Yung); There's a Cabin in the Pines (Hill); You're an old Smoothie (Whiting). 1.0 a.m., Mandoline Band: The Blue Danube (Strauss); In Old Seville (Ege); Mandolinata (di Pietro); Some of these days (Brookes); Czardas (Monti); Mandoline (Thomé); Loin du bal (Gillet). 1.30, Choral Music: When the Lilac blooms again (Rotter); The Lincolnshire Poacher (Trad.); Minstrel Memories; Orchestral, Overture, 1914 (arr. Somers); The Flower of Hawaii (Abraham); Chinatown, Chinatown (Schwartz); Mighty like a Rose (Clutsum); Orchestra: Waltz Favorites (Ancliffe). 2.0, I.B.C. Goodnight Melody and Close Down.

**FLENSBURG.**—See Hamburg.  
**FLORENCE.**—See Turin.

**FRANKFURT**

1,157 kc/s, 259.3 metres; 17 kW. Relayed by Cassel, 1,220 kc/s, 245.9 metres; and Trier, 1,157 kc/s, 259.3 metres.—12.15 p.m., Time and News. 12.25, Local News and Weather. 12.35, See Stuttgart. 1.40, Hints for the Housewife. 2.30, Weather. 2.40, Time and Market Prices. 3.0, See Langenberg. 5.0, Italian Lesson. 5.20, On the Conveyer Belt—Miniature Report and Discussion. 5.35, Talk on Education. 5.50, Weather and News. 6.0, Transmission for all German Stations, relayed from Berlin (Deutschlandsender). 7.0, See Berlin (Deutschlandsender). 7.10 to 9.0, See Langenberg. 9.0, Time and News. 9.20, See Stuttgart. 9.30, Local News and Weather. 9.45, See Stuttgart. 10.0, Programme to be announced. 10.30, See Stuttgart. 11.0 (also on Zeesen, 31.38 metres), Talk: The German Lyric. 11.45 (approx.), Close Down.

**FREDERIKSSTAD.**—See Oslo.  
**FREIBURG.**—See Stuttgart.  
**GENEVA.**—See Radio-Suisse Romande.  
**GENOA.**—See Turin.  
**GLEIWITZ.**—See Breslau.  
**GÖTEBORG.**—See Stockholm.  
**GRAZ.**—See Vienna.  
**HAMAR.**—See Oslo.

**HAMBURG**

806 kc/s, 372 metres; 1.5 kW. Relayed by Bremen, 1,112 kc/s, 269.8 metres; Flensburg and Hanover, 1,319 kc/s, 227.4 metres; and Kiel, 1,292 kc/s, 232.2 metres.—6.0 p.m., Transmission for all German Stations, relayed from Berlin (Deutschlandsender). 7.0, See Berlin (Deutschlandsender). 7.10, Concert by the Hamburg Philharmonic Orchestra, conducted by Bibenschütz: Suite No. 3 for Orchestra (Wedig); Symphony in D minor, Op. 27 (Strässer). 8.20, Magie im Hinterhaus—Radio Play (Manuel and Reimann). 9.0, Time, Weather and Announcements. 9.20, Concert of Scandinavian Music by the Small Station Orchestra. Conductor: Gerhard Maasz (Pianoforte); Overture, Nachtklänge von Ossian (Gade); Valse triste (Sibelius); Pastoral Suite No. 34 (Atterburg); Polcaise (Svendsen); Entry March of the Boyards (Halvorsen). Pianoforte Solos: (a) Evening (Palmgren). (b) Summer Evening (Grieg). (c) Nocturne (Grieg); Dance Scene (Nielsen); Ballet Suite (Gyldmark); Grottesque March (Sinding); Two Swedish Dances (Aulin); Nocturne from the Music to King Christian (Sibelius); Homage March from the Music to Sigurd Jorsalfar (Grieg).

**HANOVER.**—See Hamburg.

**HEILSBURG**

1,085 kc/s, 276.5 metres; 60 kW. Relayed by Danzig, 671 kc/s, 447.1 metres.—12.5 p.m., Gramophone Concert. In the intervals at 12.20 and at 1.0, News. 1.30, Programme arranged by the Post Office with Gramophone Records. 2.0, Market Prices. 2.5, Gramophone Music. 3.0, Humorous Talk. 3.15, Concert by the Small Station Orchestra, conducted by Wilken. Overture, The Nuremberg Doll (Adam); Suite Campestre (Anadei); Potpourri, The Three Strauses (Lindemann); Komm Cigány (Kalmán); Melody (Kalmán); Selection from The Land of Smiles (Lehár); Waltz, Nordseestürme (Dörning); Overture, Fatinitza (Suppé). In the interval at 4.0 (approx.), Talk: Moderu

Fashions. 4.40, Book Review. 4.50, Discussion for Workers: Railway Engines and Drivers. 5.15, Agricultural Prices. 5.25, Ballad Recital by Paulpeter Rafalski. Three Ballads (Loewe): (a) Prinz Eugen, (b) Heinrich der Vögler, (c) Der Wirtin Töchterlein; Die Vätergruft (Liszt); Drei Wanderer (Hermann). 5.50, Weather. 6.0, Transmission for all German Stations relayed from Berlin (Deutschlandsender). 7.0, See Berlin (Deutschlandsender). 7.30, Concert relayed from London. 8.0 (from Danzig), Concert by the Danzig Municipal Theatre Orchestra, conducted by Lenzer. Jubelouverture (Flotow); Scandinavian Folk Music (Hartmann); Prelude to the Second Act of Die Königskinder (Humperdinck); Kavalier-Walzer (Neubal); Selection from La Bohème (Puccini); Overture, The Kiss (Smetana). 9.0, News, Weather and Sports Notes. 9.15 (approx.), Political Press Review, relayed from Berlin (Deutschlandsender).

**HILVERSUM**

1,013 kc/s, 296.1 metres; 7 kW up to 5.40 p.m. and 20 kW from 5.40 p.m. Programme of the General Broadcasting Society (A.V.R.O.).—11.41 a.m., Concert by the Wireless Orchestra, conducted by Nico Treep: Overture, Light Cavalry (Suppé); Ballet égyptien (Luigini); Slav Dances Nos. 6 and 8 (Dvorák); Dance Suite from The Bartered Bride (Smetana); March, On the Quarter Deck (Alford); Gramophone Records; Splendour and Victory (Finck); Waltz, Hereinspaziert (Ziehrer); Spanish Legend (Rust); Rain and Shine (Krome); A Little Flirtation (Lautenschläger); Was kommt dort von der Höh (Suppé); Gramophone Records; A Japanese Carnival (de Basque); Selection from Le petit duc (Lecocq); Im schönen Tal der Isar (Löhner). 1.55, Interval. 2.10, Orchestral Concert (cont'd.). Marche solennelle (Tchaikovsky); A Summer Night in Madrid (Glinka); Selection from Turandot (Puccini). 2.40, Dressmaking Lesson. 3.40, Ballad Recital by Kaiser: Two Songs (Schubert): (a) Der Doppelgänger, (b) Heilopolis. Two Songs (Schumann): (a) In der Fremde, (b) Freistm. Two Songs (Brahms): (a) Nachtwandler, (b) Die Maianacht. Two Songs (Hugo Wolf): (a) Der Freund, (b) Der Musikant. Two Songs (R. Strauss): (a) Traum durch die Dämmerung, (b) Heimliche Auforderung. Two Songs (Koetsier): (a) Schlussstück, (b) Lob der Faulheit. 4.10, Concert by a Children's Choir, conducted by Jacob Hamel. 4.40, Programme for Children. 5.10, Talk. 5.40, Gramophone Music. 6.40, Talk: The Stamp Collector. 6.55, Gramophone Music. 7.10, English Lesson. 7.40, Time Signal and News. 7.45, Talk on the Salvation Army. 8.0, Concert of Light Music by Kovacs Lajos and his Orchestra. Interludes by the Fidelio Singers. 8.55, Gramophone Music. 9.10, French Song Recital by Yvette Guilbert. 9.30, Concert by the Wireless Orchestra, conducted by Nico Treep. Soloist: Wilhelm Strienz (Bartone); Overture, The Italian Girl in Algiers (Rossini); Arias from (a) Don Carlos (Verdi), (b) Eugene Onegin (Tchaikovsky), (c) The Bartered Bride (Smetana); Hungarian Rhapsody No. 1 (Liszt); Songs from (a) Gasparone (Müllhofer-Steffan), (b) Das Fürstentum (Lehár), (c) Der Toni aus Wien (Steffan); Waltz, Dolores (Waldteufel); Overture, Le roi d'Yvetot (Adam); Melody (Lincke). 10.40, News. 10.50, Concert of Light Music. 11.40 (approx.), Close Down.

**HORBY.**—See Stockholm.

**HUIZEN**

160 kc/s, 1,875 metres; 7 kW until 3.40 p.m. Transmitter from Kootwijk on 50 kW from 3.40 p.m. Programme of the Catholic Radio Society (K.R.O.).—11.55 a.m., Concert by the K.R.O. Sextet: Im Zigeunerlager (Oschelt); Serenade, Il bacio (de Micheli); Waltz, Acceleration (Jos. Strauss); Doubt (Oschelt); Selection from Samson and Delilah (Glinka); Arabian Dance (Kruger); Gramophone Music; Bei der Zigeunerkapelle (Meyer-Helmund); Tarantelle brillante (Smith); Lehár, Potpourri (Geiger); Barcarolle (Waldteufel); Russian Songs (Smith); Finale. 1.40 p.m., Programme for Women. 2.40, Dressmaking Lesson. 3.40, Interval. 3.55, Gramophone Music. 4.10, Concert by the K.R.O. Orchestra, conducted by Gerritzen: Selection from Die Königskinder (Humperdinck); The Mastersingers (Wagner); Lohengrin (Wagner). 4.30, Tenor Song Recital by van den Berk: Selection from La Traviata (Verdi) and Rigoletto (Verdi). 4.40, Orchestral Concert (cont'd.); Overture, Samson (Handel); Mother Goose Suite (Ravel). 5.0, Song Recital (cont'd.): Lolita (Buzzi-Peccia); Zwei Märchen-Augen (Kálmán). 5.10, Orchestral Concert (cont'd.): Selection from A basso porto (Spinelli); Extract from Schwanda the Piper (Weinberger); Selection from Boris Godunov (Mussorgsky); Rhapsody No. 14 (Liszt). 5.40, Song Recital (cont'd.): Gern hab' ich die Frauen geküsst (Lehár); Das Zauberbild (Meyer-Helmund); 5.50, Orchestral Concert (cont'd.): Johann Strauss Music; Overture, Eine Nacht in Venedig; Selection from Die

Fledermaus; Wildfeuer Polka; Selection from The Gipsy Baron; Selection from Frühlingsluft. 6.20, Esperanto Lesson. 6.40, Police Notes. 6.55, Literary Talk. 7.15, Gramophone Music. 7.25, Talk. 7.40, Gramophone Music. 7.50, News. 7.55, Samson—Oratorio (Handel), by the Choir of the Catholic Oratorio Association, Amsterdam. Soloists: Urlus (Tenor), van Breemen (Soprano), Annie Woud (Contralto), and Funke Küpper (Bass). In an interval at 9.10, Gramophone Music. 10.10, News. 10.15, Gramophone Music. 10.40, Concert by the K.R.O. Boys, conducted by Lesteuhouwer. 11.40 (approx.), Close Down.

**INNSBRUCK.**—See Vienna.

**JUAN LES PINS**

NICE, 1,205 kc/s, 249 metres; 0.8 kW.—8.0 p.m., Amusement Guide, Financial Report, Exchange and News. 8.10, Agricultural Review. 8.20, English Lesson. 8.35, Concert. In the interval at 9.0, Announcements and Weather.

**KALUNDBORG.**—See Copenhagen.

**KIEL.**—See Hamburg.

**KLagenfurt.**—See Vienna.

**KOSICE.**—See Prague.

**LANGENBERG**

635 kc/s, 473 metres; 60 kW.—12.5 p.m., Programme from Frankfurt. 12.25, News and Weather. 12.35, Concert from Stuttgart. 2.0, Violin and Harmonium Recital by Jakob Braun and Willi Jansen: Berceuse (Juon); Prelude (Kisfeller). 2.15, Talk: Characteristics of the New German Traffic Policy. 2.30, Economic Notes. 2.50, Political Address. 3.0, Musical Programme. Part I, Songs from an old Liederbuch. Part II, Dance Music by the Station Band, conducted by Kühn. Part III, Gramophone Records of the Cast of the Milan, Scala. 5.0 to 5.35, See Frankfurt. 5.50, News. 6.0, Transmission for all German Stations, relayed from Berlin (Deutschlandsender). 7.0, See Berlin (Deutschlandsender). 7.10, Dance Music by the Station Band, conducted by Kühn. In the intervals, Music for Old Instruments, by Rudi Rhein (Violin), Robert Grote (Viola de Gamba), and Hans Haas (Harpischord). Concerto in E for Harpischord, Violin, and Viola da Gamba (Teleman); Variations for Harpischord and Viola da Gamba (Haydn). 8.0, The German Village—Radio Sequence (Lützel). 9.0, See Frankfurt. 9.20, See Stuttgart. 9.30, News, Weather, and Sports Notes. 9.45, See Stuttgart. 10.0, Programme to be announced. 10.30, See Stuttgart. 11.0, See Frankfurt. 11.45 (approx.), Close Down.

**LAUSANNE.**—See Radio-Suisse Romande.

**LEIPZIG**

770 kc/s, 389.6 metres; 120 kW. Relayed by Dresden, 991 kc/s, 319 metres.—12.30 p.m., Music from New Operettas and Sound Films on Gramophone Records. 1.15, News. 1.30, Interval. 2.0, Soprano, Flute and Pianoforte Recital. 2.35, Market Prices. 3.0, Dances of the Nations—Concert by the Leipzig Symphony Orchestra, conducted by Hilmar Weber: German Dances (Schubert); Swedish Dances (Bruch); Norwegian Dances (Grieg); Viennese Dances (Beethoven); Russian Dances, Trepak (Tchaikovsky); Chinese Dance (Tchaikovsky); Slow Waltz, Loin du bal (Gillet); Hungarian Dances (Brahms); Romanian Dances (Bela Bartok); Spanish Dance, Bolero (Nicolé); Slav Dances (Dvorák); Dances from Gotland (Aulin); Icelandic Dances (Leifs); Piedmontese Dances in A (Sinigaglia). 4.30, Books are waiting for: Der Ritt nach Canossa (Otto Nebelthad). 5.0, Talk: Chemicals as weapons of war: The Ostrogoths. 5.15 (from Dresden), Ballad Recital by Georg Zottmayr: Three Ballads (Loewe): (a) Heinrich der Vögler, (b) Der Nöck, (c) Odins Neeresritt; Drei Wanderer (Hermann). 5.40, Market Prices and News. 6.0, Transmission for all German Stations, relayed from Berlin (Deutschlandsender). 7.0, See Berlin (Deutschlandsender). 7.10, Jugens fahren ins Mittelalter (Boys return to the Middle Ages)—A Radio Scene, played by the Leipzig Hitler Jugend. 7.55, Cabaret Programme. 8.25, String Quartet in G. Op. 161 (Schubert), played by the Dresden String Quartet. 9.0, News and Sports Notes. 10.0, Programme to be announced. 10.30, German Student Songs (on Gramophone Records). 11.0 (approx.), Close Down.

**LINZ.**—See Vienna.

**LJUBLJANA**

522 kc/s, 574.7 metres; 7 kW.—6.0 p.m., French Lesson. 6.30, Educational Talk. 7.0, Guitar Duets. 7.40, Duets. 8.30, Time and News. 8.50, Orchestral Concert. 9.30 till Close Down, I.B.C. Concert: My Wishing Song (Burke); Spanish Sweetheart (Hargreaves); Old Spotted Cow (Stanly); Flor de

Cuba (Gregor); Then the Moon came out (Miller); Heaven will protect an Honest Girl (Weston); I lay me down to Sleep (Wrubel); When my Little Pomeranian (Little).

**LUXEMBOURG**

252 kc/s, 1,191 metres; 200 kW.—Belgian Evening. 7.0 p.m., Gramophone Concert: Symphony No. 6 in B flat Minor, Op. 74—the "Pathetic" (Tchaikovsky); Le chasseur maudit (César Franck). 8.0, Song Recital by Bracony: Aria from L'Oronte (Cesti); Hans Sachs' Monologue from The Mastersingers (Wagner); Träume (Wagner); Clair de lune (Fauré); Hindou Song (Bemberg); Danse macabre (Saint-Saëns). 8.30, Iberia Suite (Debussy) on Gramophone Records. 8.50, News in French. 9.0, Concert by the Station Orchestra, conducted by Henri Feinis, relayed from the Casino. Soloist: André Cassedanne (Violin). Overture, Prometheus (Beethoven); Concerto in A Minor for Violin and Orchestra (Dvorak). 9.45, News in German. 9.55, Concert (cont'd.): Prelude to The Mastersingers (Wagner); Pavane pour une Infante défunte (Ravel); Suite pour mes petits Amis (Pierné); The Witches' Sabbath (MacDowell); Nocturne (Grieg); The Flight of the Bumble Bee (Rimsky-Korsakov); Overture, Die Fledermaus (Joh. Strauss). 10.45, Dance Music on Gramophone Records.

**MADRID**

ARANJUEZ (EAQ), 10,000 kc/s, 30 metres; 20 kW.—10.30 p.m., Concert of Popular Music. In the interval at 10.45, Radio Chronicle. 11.45, Light Music. 12 Midnight till Close Down, I.B.C. Concert of Light Music: Tiptoe through the Tulips (Dubin); Now I am in Love (Shapira); Beautiful Spring (Lincke); An Old Blind Man (Castillo); Capulitto de Albeli (Lecuona); Marta (Simons); Black-eyed Susan Brown (Hoffmann); Selection from The Count of Luxembourg (Lehár). 12.30 a.m. (Wednesday), I.B.C. Good-night Melody and Close Down.

**MADRID**

EAJ7, 707 kc/s, 424.3 metres; 2 kW.—7.0 p.m., Chimes, Exchange, Topical Talk and Dance Music. 7.30, Talk by Joaquin España Cantos, Talk on Hygiene, and Dance Music (cont'd.). 8.15, Radio Journal. 8.30 to 9.15, Interval. 9.15, English Lesson. 9.30, Chimes, Time and Radio Journal. 9.45 (approx.), Music Competition—Saetas—Musical Play (Rebollo and Aquino). 11.45, Radio Journal. 12 Midnight, Chimes. 1.0 a.m. (Wednesday), till Close, I.B.C. Concert of Dance Music: Oh Peter; Learn to Croon; Times from 1914-1930; Margie; Moonstruck; My Wishing Song; Twist the Devil and the Deep Blue Sea; Under a Blanket of Blue; Wild Goose Chase; Love is the Thing; Selection from A Bedtime Story; Peter, Peter; Avalon; Scotch Hot; One Tiny Tear; I bring a Song. 2.0, I.B.C. Good-night Melody and Close Down.

**MALMO.**—See Stockholm.

**MILAN.**—See Turin.

**MORAVSKA-OSTRAVA**

1,137 kc/s, 263.8 metres; 11 kW.—6.0 p.m., See Prague. 6.30, See Brno. 9.0, See Prague. 10.0 (approx.), Close Down.

**MOTALA.**—See Stockholm.

**MUHLACKER.**—See Stuttgart.

**MUNICH**

563 kc/s, 533 metres; 1.5 kW. Relayed by Augsburg and Kaiserslautern, 536 kc/s, 560 metres; and Nürnberg, 1,256 kc/s, 239 metres. 3.30 p.m., Concert from Langenberg. 4.45, The History of the Fichtelgebirge—Radio Report (Bayerl). 5.5, The Great Gate of Kiev—Melodrama (Kühne-Hellmessen) set to Music from Mussorgsky's Pictures from an Exhibition. 5.25, Talk: Max von Pettenkofer. 5.45, Time, Weather and Agricultural Notes. 6.0, Transmission for all German Stations, relayed from Berlin (Deutschlandsender). 7.0, See Berlin (Deutschlandsender). 7.15, A Garland of Song—Lyric Play (Konrad Scherber) by the Station Orchestra, a Mixed Vocal Quartet and Soloists. 8.15, Important New Gramophone Records. 9.0, Time, Weather and Announcements.

**NAPLES.**—See Rome.

**NOTODDEN.**—See Oslo.

**OSLO**

277 kc/s, 1,083 metres; 60 kW. Relayed by Fredriksstad, 815 kc/s, 368.1 metres; Hamar, 522 kc/s, 574.7 metres; Notodden, 671 kc/s, 447.1 metres; Porsgrund, 662 kc/s, 453.1 metres; Rjukan, 671 kc/s, 447.1 metres; and Jelsøy, L.O.L., 6,990 kc/s, 42.92 metres.—5.0 p.m., Programme for Housewives. 5.45, Accordion Duet Recital of Popular Music and Dance Music, by Johannes Larsen and Ole Rønning. 6.0, Announcements, Weather and News. 6.30, English Lesson. 7.0, Time Signal. 7.1, Pieces en concert for 'Cello (Couperin), by Yrjö Arams Selin. 7.30, Talk: The Excavations at Ur. 8.0, Concert by the Station Orchestra, conducted by Kramm: Nada y Muche for String Orchestra, Trumpet, Guitar and Pianoforte (de

NOV. 28th **TUESDAY** continued

Arriaga); Festival Suite (Klass); Selection from Noel Coward's Cavalcade (arr. Jones); Selection from Les brigands (Offenbach); Suite from The Blue Mazurka (Lehar); Viennese Operetta Potpourri (Hruby). In the interval at 8.40, Weather and News, and at 9.0, Topical Talk.

**OSTERSUND**.—See Stockholm.

**PALERMO**

556 kc/s, 539.5 metres; 3 kW.—7.0 p.m., Dopolavoro Announcements, Tourist Talk, Agricultural Notes and Giornale Radio. 7.20, Gramophone Music. In the interval at 7.30, Time and Announcements. 7.45, Othello—Opera (Verdi) on Gramophone Records. In the intervals, Talk and Announcements. 10.0, Giornale Radio.

**PARIS**

**EIFFEL TOWER**, Call FLE, 207.5 kc/s, 1,445.7 metres; 13 kW.—Time Signals (on 2,650 metres) at 9.26 a.m. and 10.26 p.m. (Preliminary and 6-dot Signals).—5.45 p.m., Le Journal Parlé. 7.15, Weather. 7.25, News. 7.30, Light Music on Gramophone Records. 7.45, Art Notes. 8.0, Science Talk. 8.15, Political Review. 8.30, On ne badine pas avec l'amour—Play (de Musset), with Music by Saint-Saëns.

**PARIS**

**POSTE PARISIEN**, 914 kc/s, 328.2 metres; 60 kW.—7.0 p.m., Gramophone Music. 7.5, Sponsored Programme. 7.15, Le Journal Parlé. 7.30, Gramophone Music. 8.0, Talk on the Music Hall. 8.5, Film Review. 8.15, Concert by the Station Orchestra, conducted by Théodore Mathieu. 10.30, News.

**PARIS**

**RADIO PARIS**, Call CFR, 174 kc/s, 1,725 metres; 75 kW.—6.45 a.m., Gymnastics. 7.30, Weather and Gymnastics. 7.45, Gramophone Music: Tango (Albeniz); Slav Dances (Dvorak); Polichinelle (Rachmaninov); Tambourin chinois (Kreisler). 8.0, Press Review and Weather. 12 Noon, Gramophone Concert: Part I—Ballet Music from Opera; Ballet Music from Faust (Gounod); Le Cid (Massenet), Samson and Delilah (Saint-Saëns), Prince Igor (Borodin) and Marouf (Rabaud); Part II—Arias from French Operettas; Arias from Madame Favart (Offenbach), Madame l'Archiduc (Offenbach), La belle Héloïse (Offenbach), La périoche (Offenbach), Les byrigands (Offenbach), Les mousquetaires au couvent (Varney) and Ciboulette (Hahn). In the interval at 1.30 p.m., Exchange. 2.0, Exchange. 3.45, Exchange and Market Prices. 4.30, Elementary English Lesson. 4.50, Interval. 6.20, Agricultural Talk. 6.40, German Lesson. 7.0, Theatre Review. 7.20, Gramophone Music: Three Pieces (Debussy): (a) Hommage à M. Pickwick, (b) Minstrels, (c) General Lavine; Sur l'eau (Pedrell); La Franc-comtoise (de Livry); Le bon roi Dagobert (Humble); Chants d'auvergne (Canteloube). 7.45, Review of the Anglo-Saxon Press. 8.0, Radio Paris Music Hall: Part I—Items by Mme. Maud Gipsy (Disseuse); Part II—Duets by Edi and Jean. 8.40, Review by Pierre Scize. 8.45, Songs. 9.15, Press Review and News. 9.30, Music by Mayamba and his Black and White Band.

**PITTSBURGH**

**KDKA**, 980 kc/s, 306 metres; 50 kW. Relayed by W6XK on 48.85 metres and 25.27 metres.—7.0 p.m., Four Aces. 7.15, Musical Originalities, from New York. 7.30, KDKA Home Forum. 8.0, Rochester Orchestra, from New York. 9.0, Betty and Bob, from New York. 9.15, Congress of Clubs. 9.30, News and Market Reports. 9.45, Brown Palace Orchestra, from New York. 10.15, KDKA Kiddies' Klub. 10.30, Singing Lady, from New York. 10.45, Orphan Annie, from New York. 11.0, News and Pat Haley. 11.15, Sports and Programme Review. 11.30, Evening. 11.45, Lowell Thomas, from New York. 12 Midnight, Amos 'n' Andy, from New York. 12.15 a.m. (Wednesday), Marvellous Melodies. 12.30, Lois Miller, Organist. 12.45, Programme to be announced. 1.0 to 2.30, New York Relay. 1.0, Crime Clues. 1.30, Adventures in Health. 1.45, Trade and Mark. 2.0, Musical Memories. 2.30, Programme to be announced. 3.0, Ortiz Tirado, from New York.

**PORSGRUND**.—See Oslo.

**PRAGUE**

614 kc/s, 488.6 metres; 120 kW.—3.0 p.m., See Bratislava. 3.55, Programme from Brno. 4.15, Programme for Workers. 4.25, Gramophone Records. 4.35, German Conversation Lesson. 4.50, Gramophone Music. 5.5, Market Prices. 5.15, Review of Events in Russia. 5.25, News in German. 5.30, German Transmission: Talk: Modern Viennese Poetry. 6.0, Time, News and Weather. 6.10, Talk: The Changing World. 6.30, Concert by the Prague Wind Quintet. March from Figaro (Mozart); Overture, Le petit duc (Lecocq); Waltz (Chopin); Scherzo, Op. 4 (Fibich); Item to be announced); Polka (Splitek); Country Serenade (Kubin). 7.0, See Brno. 9.0, Time, News and Sports Notes. 9.15, New Gramophone Records. 10.0 (approx.), Close Down.

**RADIO-SUISSE ROMANDE**

**SOTTENS**, 743 kc/s, 403 metres; 25 kW.; and Geneva, 490 kc/s, 749.9 metres.—6.0 to 6.15 a.m. (from Lausanne), Gymnastics. 11.28, Time Signal from Neuchâtel Observatory. 11.30, News and Weather. 11.40 (from Geneva), Gramophone Concert. 12 Noon (from Geneva), Gramophone Concert (contd.). 1.0, Interval. 2.58, Time Signal from Neuchâtel Observatory. 3.0 (from Lausanne), Concert by the Small Radio Lausanne Orchestra, conducted by Moser. Part I: Chamber Music: First and Second Movements from the Trio, Op. 100, for Pianoforte, Violin and Cello (Schubert). Part II: Three Pieces for Strings: (a) Sailor Dance (Dumhill), (b) Pastoral Dance (Demuth), (c) Carillon (Pascal); Potpourri, Servus Wien (Dostal); Intermezzo (Ketelbey); Alpine Fête (Naef); Tarantella for Flute and Clarinet (Saint-Saëns); Selection from The Duchess of Chicago (Kalman). Part III: Folk Music. Part IV: Dance Music. 5.0 (from Lausanne), Programme for Women. 5.30 (from Lausanne), Talk: Victor Hugo. 5.55 (from Lausanne), German Lesson. 6.20 (from Lausanne), Theatre Talk. 6.45 (from Lausanne), Concert by the Small Radio Lausanne Orchestra, conducted by Moser. 7.30 (from Lausanne), L'ami Fritz—a Play in Three Acts (Erckmann-Chatrian). In the interval at 8.30 (approx.), News and Weather. 9.40 (approx.), Close Down.

**RJUKAN**.—See Oslo.

**ROME**

Call IRO, 680 kc/s, 441 metres; 50 kW. Relayed by Naples, 941 kc/s, 319 metres; Milan (Vigentino), 662 kc/s, 453.1 metres from 7.45 p.m.; and 2RO, 11,810 kc/s, 25.4 metres.—12 Noon to 1.15 p.m., Trio Concert from Turin. In the intervals from 12.30 to 12.45, Giornale Radio and Exchange, and at 1.0, Time and Announcements. 3.30, Children's Radio Review. 3.55, Giornale Radio and Exchange. 4.10, Weather. 4.15 to 5.0, Orchestral Concert: Storz mentale (Escobar); Scherzo (Adams); Immer glücklich (Künneke); Selection from I carusciacci (Lacchetti); Dream Waltz (Ramoldi); Extracts from The Nutcracker Suite (Tchaikovsky); Happy Jett (Borgato). 5.40 (Naples), Shipping and Sports Notes. 5.45, Lesson in Morse and Dopolavoro Report. 6.0, Tourist Report. 6.10, Wheat Market Report. 6.20, News in Foreign Languages. 6.40, Giornale Radio. 7.0, Time and Announcements. 7.15, Gramophone Music. 7.30, Sports Notes. 7.45, Variety Music. 8.30, Dramatic Programme. 10.0, Giornale Radio.

**SALZBURG**.—See Vienna.

**SCHENECTADY**

**WGY**, 790 kc/s, 379.5 metres; 50 kW. Relayed at intervals by W2XAF on 31.48 metres; and by W2XAD on 19.56 metres.—12.45 a.m. (Wednesday), Stock Reports. 1.0 to 3.45, New York Relay. 1.0, Popular Programme. 1.30, Wayne King's Orchestra. 2.0, Ben Bernie's Blue Ribbon Orchestra. 2.30, Ed Wynn and the Fire Chief Orchestra. 3.0, Lives at Stake. 3.30, Variety Programme. 3.45, Pianoforte Pals and Programme Résumé.

**SCHWEIZERISCHER LANDESENDER**

**BEROMUNSTER**, 653 kc/s, 459 metres, 60 kW.: Basle, 1,229 kc/s, 244.1 metres; and Berne, 1,220 kc/s, 245.9 metres.—5.50 a.m. to 6.5, Gymnastics. 11.0 (from Zürich), Hints for Housewives. 11.5 (from Zürich), Light Music by the Station Orchestra, conducted by Neppach. 12.25 p.m. (from Zürich), Time, Weather and Exchange. 2.30 (from Zürich), Concert by the Small Station Orchestra, conducted by Scherbaum. 3.0, See Radio-Suisse Romande (Sottens). 5.0 (from Berne), Gramophone Concert. 5.30 (from Berne), Medical Talk. 6.0 (from Berne), Time, Weather, and Broadcast for Schools. 6.10 (from Berne), Talk: Unknown Ski-ing Grounds. 6.20 (from Berne), Radio Report. 6.50 (from Berne), Concert of Renaissance and Baroque Chamber Music by the Freiburg Trio. 7.30 (from Berne), Reading: Fairy Tales from Five Continents. 8.0, Weather and News. 8.10 (from Berne), Scenes from Mozart's Life—Opera (Lortzing). 9.15 (approx.), Close Down.

**SOTTENS**.—See Radio-Suisse Romande.

**STOCKHOLM**

689 kc/s, 436 metres; 55 kW. Relayed by Boden, 242 kc/s, 1,239.5 metres; Göteborg, 932 kc/s, 322 metres; Hörby, 1,167 kc/s, 257 metres; Motala, 222.5 kc/s, 1,348 metres; Östersund, 402 kc/s, 746.2 metres; and Sundsvall, 554 kc/s, 542 metres.—4.45 to 2.10 p.m., Broadcast for Schools. 4.5, Play for Children. 4.45, Gramophone Music. 5.45, Ele-

mentary French Lesson. 6.15, Weather and News. 6.30, Talk: The Problem of International Debts. 7.0, Concert by the Radio Orchestra, conducted by Nils Grevilius; Soloist, Fritlof Kjellberg (Pianoforte); Overture, Abencerrages (Cherubini); Pianoforte Concerto in A (Mozart); Musette from Christian II (Sibelius); Ballet Suite (Reuss); Norwegian Rhapsody, No. 1 (Halvorsen). 8.15, Literary Recital. 8.45, Weather and News. 9.0, Song Recital by Magnus Strömbohm. 9.15, Concert by the Harman Mårtenssons Ensemble: Moment musical (Schubert); Liebestier (Weingartner); Selection from I Pagliacci (Leoncavallo); Piece (Merikanto); Minuet (Mayer); Serenade (Tosti); The Phantom Brigade (Myddleton); Popular Melodies (Kahrman). 10.0 (approx.), Close Down.

**STRASBOURG**

869 kc/s, 345 metres; 11.5 kW.—11.30 a.m., Gramophone Music. 12 Noon, Orchestral Concert, conducted by Maurice de Villars: Overture, Il Seraglio (Mozart); Overture, Fidelio (Beethoven); Overture, Fingal's Cave (Mendelssohn); Overture, Manfred (Schumann); Overture, Phèdre (Massenet). 12.45 p.m., News, Time and Exchange. 1.5, Concert (contd.): Ballet Music from Hamlet (Thomas); Suite for Orchestra, Bouton d'or (Pierné); Petite suite (Debussy); Bolero (Ravel). 2.0, Interval. 4.45, Talk in French: Cochon China. 5.0, Concert of Light Music, conducted by Roskam: March, Les travaux d'Hercule (Terrasse); Waltz (Ziehrer); Promenade matinale (Lacombe); Overture, I love you (Fourdrain); Violin Solos: Ariette and Orientale (Erh); Selection from Monsieur Beaucaire (Mésanger); Two Pieces (Chaminade): (a) Sérénade d'automne, (b) Pierrette; Suite, Lanterne magique (Godard); March, L'esprit français (Messacapo). 6.0, Talk on History. 6.15, Topical Talk. 6.30, Orchestral Concert, conducted by Maurice de Villars: Polonaise from Eugene Onegin (Tchaikovsky); Waltz Overture, The Barber of Seville (Rossini); Symphonic Poem, Phaëton (Saint-Saëns); Selection from The Pearl Fishers (Bizet); Ballet Music from Patrie (Paladilhe). 7.30, Time and News. 7.45, Gramophone Music. 8.0, Press Review in German. Lottery Results and Announcements. 8.30, See Paris (Eiffel Tower). 10.30 (approx.), Press Review.

**STUTTGART**

**MUHLACKER**, 832 kc/s, 360.5 metres; 1.5 kW. Relayed by Freiburg, 527 kc/s, 570 metres.—12.25 p.m., Local News and Weather. 12.35, Gramophone Records of the Otto Kernbach Orchestra. 1.30, Talk on Flowers. 3.0, See Langenberg. 5.0, See Frankfurt. 5.35, Agricultural Programme. 5.50, Time and Weather. 6.0, Transmission for all German Stations, relayed from Berlin (Deutschlandsender). 7.0, See Berlin (Deutschlandsender). 7.10, See Langenberg. 9.0, See Frankfurt. 9.20, Things you should know. . . . 9.30, Local News, Weather, and Sports Notes. 9.45, Gramophone Music. 10.0, Programme to be announced. 10.30, Music by a Wind Band. 11.0, See Frankfurt. 11.45 (approx.), Close Down.

**SUNDSVALL**.—See Stockholm.

**TOULOUSE**

779 kc/s, 385 metres; 8 kW.—6.0 p.m., News. 6.15, Accordion Solos. 6.30, Chansonnettes. 6.45, Instrumental Solos. 7.0, Operetta Music. Arias from La petite dancie du train bleu (Parès and Van Parys), Les mousquetaires au couvent (Varney), Louis XIV (Parès and Van Parys) and Les cloches de Corneville (Planquette). 7.15, News. 7.30, Symphonic Poem, Don Juan (R. Strauss), by the Symphony Orchestra. 7.45, Songs. 8.0, Organ Recital. Waltz, Gold and Silver (Lehár); Träumerei (Schumann); Finale from a Concerto (Handel); Plaisir champêtre. 8.15, Opera Music. Arias from Lakmé (Delibes), Mignon (Thomas), Louise (Charpentier) and Mirella (Gounod). 8.30, Orchestral Concert. Marche militaire No. 1 (Schubert); The Turkish Patrol (Michaelis); Petite Suite de Concert (Coleridge Taylor); Humoresque (Dvorak); Hindu Song (Rimsky-Korsakov); Minuet (Howells); Bourrée in B minor (Bach). 9.0 Italian Songs. Cor mio mente vu miro: Prologue to I Pagliacci (Leoncavallo); Neapolitan Song, Canta pe' me (de Curtis); Aria from Martha (Flotow); Aria from La Bohème (Puccini); Tamo; Potpourri of Italian Arias. 9.30, Light Music. 9.45, Music from Sound Films. 10.0, Military Music. 10.15, News. 10.30, Concert for Listeners in Morocco. Part I. Opera Arias. Arias from Prince Igor (Borodin), Hamlet (Thomas) and Parsifal (Wagner). Part II. Light Music by a Viennese Orchestra. 11.0, Chansonnettes. 11.15, Dance Music. 12 Midnight, News and Weather. 12.5 a.m. (Wednesday), Music by an Argentine Band. 12.15, Hunting-Horn Solos. Messe solemnelle de St. Hubert (Blondiaux); La chasse française (Blondiaux). 12.30 (approx.), Close Down.

**TRIESTE**

1,211 kc/s, 247.7 metres; 10 kW.—4.10 p.m. till Close Down, See Turin.

**TRONDHEIM**.—See Oslo.

**TURIN**

1,096 kc/s, 273.7 metres; 7 kW. Relayed by Milan, 903 kc/s, 332.2 metres; Genoa, 959 kc/s, 312.8 metres; and Florence, 598 kc/s, 501.6 metres.—4.10 p.m., Dance Music. 5.0 to 5.5, Weather. 5.40, Giornale Radio, Dopolavoro Announcements and Gramophone Music. 6.0, Time, Report of the Royal Geographical Society and Gramophone Music. 6.10, Wheat Market Report. 6.20, News in Foreign Languages. 6.40, Gramophone Music. 7.0, Announcements, Giornale Radio, Sports Review, Weather and Gramophone Music. 7.30, Concert for the Ninth Anniversary of the Death of Puccini. Talk in the interval. 9.0, Dance Music. 10.0, Giornale Radio.

**VATICAN CITY**

15,120 kc/s, 19.84 metres (Morning); and 5,969 kc/s, 50.26 metres (Evening); 10 kW.—10.0 to 10.15 a.m., Religious Information in English. 7.0 to 7.15 p.m., Religious Information in Italian.

**VIENNA**

580 kc/s, 517.2 metres; 100 kW. Relayed by Graz, 852 kc/s, 352.1 metres; Innsbruck, 1,058 kc/s, 283 metres; Klagenfurt, 662 kc/s, 453.1 metres; Linz, 1,220 kc/s, 245.9 metres; and Salzburg, 1,373 kc/s, 218.5 metres.—11.0 a.m., Concert by the Wiener Symphoniker, conducted by Josef Holzer: March, Wiener-Hallo (Recktenwald); Overture, Baron Trenck (Albini); Selection from Faust (Gounod); Sérénade florentine (Godard); Waltz, Myrtenblüten (Joh. Strauss); Song, Mädel, die Stunde der Liebe ist da (Schubert-Berté); Das Herz des Pierrot (Clemus); Extase (Ganne). 12 Noon, Time, Weather and Programme Announcements. 12.10 p.m., Concert (contd.): March, Fesch und schneidig (Rameis); Overture, Frau Luna (Lincke); Two Songs (Granichstaedten): (a) Zuseh'n kann i net, (b) Wann die Musik spielt; Waltz, Die letzten Tropfen (Kratzl); Poème orientale (Werna); Intermezzo, Amoretten (Schmelting); Song, Märchen, die der Wind erzählt (Silvling); Selection from Zigeunerprimas (Kálmán). 1.0 to 2.0, Interval. 2.0, Time and Announcements. 2.15, Programme for Children. 2.55, Gramophone Concert of German Opera Music: Overture, The Merry Wives of Windsor (Nicola); Aria from Der Freischütz (Weber); Selection from Siegfried (Wagner); Finale from the Second Act of Der Rosenkavalier (Richard Strauss). 3.25, Guessing Competition. 3.55, Talk: The Works of the Old Dutch Painters. 4.20, Song and Violin Recital by Maria Derip-Spitzmüller (Soprano) and Wilhelm Müller: Sonata in B flat for Violin and Pianoforte (Mozart); Songs (Richard Strauss): (a) Freundschaftliche Vision, (b) Ständchen; Song, Hat dich die Liebe berührt (Mars); Song, Abend atmet aus den Blütenzweigen (Max Ast); Song from Die tote Stadt (Korngold). 5.0, Talk: Dantan's Caricatures. 5.15, Talk: Man and Industry. 5.40, Elementary French Lesson. 6.0, Concert by the Wiener Symphoniker, conducted by Josef Holzer. Soloist: Mimi Brix (Soprano). Overture, Light Cavalry (Suppé); Song from Die Landstreicher (Ziehrer); Gavotte from Der Rastellbinder (Lehár); Overture to and Songs from Herbstmäder (Kálmán); March, Die Bosniaken kommen (Wagner); Waltz, Schwert und Leier (Joh. Strauss); Song, Die Musik kommt (Oscar Strauss); Song, Adieu, mein kleiner Gardeoffizier (Stolz); Potpourri, Der Traum eines Reservisten (Ziehrer). In the interval at 6.35, Time and Announcements. 7.15, Topical Talk. 7.30, Concert from London. 8.30, News. 8.45, Talk in Italian: Austria in Winter. 8.55, Concert relayed from the Hotel Krantz Ambassador. Announcements after the Programme.

**WARSAW**

212.5 kc/s, 1,411 metres; 120 kW.—10.57 a.m., Time Signal and Fanfare from St. Mary's Church, Cracow. 11.5, Sextet Concert: La Paloma (Radier); Melody (Pucik); Trio (Romberg); Selection from Viktoria and her Hussar (Abramam); Melody (Rubinstein); Romantic Waltz (Heinecke); Melody (Tosti); Intermezzo (Chapuis). In an interval at 11.30, Radio Journal and Weather. 12 Noon, Interval. 2.25, Announcements. 2.30, Economic Notes. 2.40, Light Music on Gramophone Records. 3.25, Savings Bank Correspondence. 3.40, Book Review. 3.55, Song Recital by Mme. Duducz: Song of the Golden Fish (Priemant); Invito alla danza (Respighi); Wiegand (Reger); Aria from Goplana (Zelenski); Hymn to the Sun from The Golden Cockerel (Rimsky-Korsakov); Aria from La Zingara (Donizetti); Neapolitan Tarantella (Rossini). 4.25, Talk: Making a Book, relayed from Wilno, 530 kc/s, 566 metres. 4.50, Agricultural Notes. 5.0, Talk: The Keys of Power and of Knowledge. 5.20, Pianoforte Trio in D minor, Op. 82 (Arensky). 6.0, Programme Announcements. 6.5, Miscellaneous Items. 6.25, Topical Talk. 6.40, Sports Notes. 6.47, Radio Journal. 7.0, Fatiniza—Operetta in Three Acts (Suppé). In the interval, Reading. 10.0, Weather and Police Notes. 10.5, Dance Music from the Oza.

**ZÜRICH**.—See Schweizerischer Landessender.

WEDNESDAY
NOVEMBER THE TWENTY-NINTH

ALGIERS

825.5 kc/s, 363.3 metres; 13 kW.—7.0 p.m., Financial Notes. 7.10, Shipping Notes. 7.15, Agricultural Notes and Weather Report. 7.20, Songs from Sound Films. 7.55, News. 8.0, Time Signal. 8.2, Lottery Results. 8.10, Concert by the Station Orchestra, conducted by Defosse. Overture, Patrie (Bizet); Divertissement sur des chants russes (Rahaud); Suite from L'Arlésienne (Bizet); Spanish Caprice (Rimsky-Korsakov); Prelude to the Third Act of Lohengrin (Wagner). In the interval at 9.0, Gramophone Music. 9.40, News. 9.45, Music by an Argentine Band. 9.55, News.

ATHLONE

725 kc/s, 413 metres; 60 kW.—Relayed by Dublin, 1,382 kc/s, 217 metres, and 1,337 kc/s, 224.4 metres.—1.30 to 2.30 p.m., Time Signal, Weather Report, Stock Report and Gramophone Concert. 6.0, Programme for Children. 6.45, News. 7.0, Gaelic Talk. 7.15, German Lesson. 7.30, Time Signal. 7.31, Concert by the Station Orchestra. 8.0, Vocal Duets by P. J. Byrne and W. J. Hobbs. 8.20, Florrie to the Rescue—a Play, by Mai Neville and Company. 8.50, Gaelic Song Recital by Dennis Cox. 9.5, The Station Orchestra. 9.15, Contralto Solos by Nora Finn. 9.30 to 10.30, Programme by the I.B.C. (Ireland), Ltd. 9.30, Concert. Dance Music. In the Park in Paris; Adois Juven-tur; Niagara Moon; What have we got to lose? 9.45, Broadcast of Dance Music. Signature Tune: There's a New Day Coming; I've got to sing a Torch Song; Waltzing alone with You; Oh, Johanna; Morning, Noon and Night; Signature Tune: There's a New Day Comin'. 10.0, Orchestral Concert arranged by the International Broadcasting Company (Ireland), Ltd. Humoresque (Dvorak); Song: Walther's Prize Song (Wagner); La Cinquantaine (Gabriel Marie); Racing Commentary; Down in the Forest (Landon Ronald); The Flower Song from Carmen (Bizet); Minnet (Mozart); Ballet égyptien (Luigini). 10.30, I.B.C. Good-night Melody, followed by News and Weather. 10.40, Irish Music by the Moate Ceilidhe Band. 11.0 (approx.), Close Down.

BARCELONA

EAJ1, 858 kc/s, 249.6 metres; 8 kW.—6.0 p.m., Trio Concert. Selection from Fidelio (Beethoven); Piece (Meudelsohn); The Butterfly Chase (Leopold); Romance (Rubinstein); Intermezzo (Hauregard); Serenade (Vallauri and Weber); Selection from Le roi de Lahore (Massenet). 7.0, Request Gramophone Music. 7.30, Exchange, Gramophone Music and Relay from the Ayuntamiento. 8.0, Gramophone Music. 8.30, Educational Programme: Geography and History Lesson. 9.0, Chimes, Weather, Exchange and Market Prices. 9.5, Concert by the Radio Orchestra. 10.0, Song Recital by Enriqueta Noguera. 10.30, Quartet, Op. 7 (Novak). 11.0, News and Gramophone Music. 12 Midnight (approx.), Close Down.

BARI

1,112 kc/s, 269.8 metres; 20 kW.—3.30 p.m., Programme for Children. 3.55 to 7.0, See Rome. 7.0, News in Albanian. 7.15, See Turin. 7.30 till Close Down, See Rome.

BASLE.—See Schweizerischer Landessender.

BELGRADE

698 kc/s, 429.7 metres; 2.8 kW.—6.0 p.m., Gramophone Music. 6.30, Opera Arias by Milorad Jovanovic. 7.0, Relay of an Opera from Lubljana. 9.0, Time and News. 9.15 (approx.), Gramophone Music. 9.40 Cigány Music, relayed from the Kasina Restaurant.

BERLIN

DEUTSCHLANDSENDER (Reichssender), 183.5 kc/s, 1,635 metres; 0 kW.—12.45 p.m., News. 1.0, Gramophone Concert. Draussen in der Welt (Borgmann-Buder); Am Wörther See (Koschat); Tyrolse Folk Melody; Air from Carmen (Bizet); Spanish Romance (Strauss); Manzanilla (Siegel); This is Madrid (O'Henry); Melody (Yoshitomo); Cherry Blossom Festival (Dicker); Sunset in Japan (Deppen); Oriental Dance (Glazunov); Hindu Song (Rimsky-Korsakov); Puzza-Grüsse (Kiss-Béla); Leinwand am Rhein (Doelle). 1.45, Programme for Children, followed by Talk: The Prevention of Cruelty to Animals. 2.10, Talk for Girls. 2.30, Weather, and Exchange. 2.45, Talk: The History of Flying—The Story of the Schneiders. 3.0, Concert, relayed from Hamburg. 4.0, Books for Young People. 4.25, Modern Chamber Music for Five Wind Instruments, by the Wind Instrument Ensemble of the Berlin Philharmonic Orchestra; Quartet for Flute, Oboe, Clarinet, Horn and Bassoon (Klinghardt); Serenade, Op. 34 (Brunner). 5.0, Poems. 5.5, Religious Address and Organ Solos. 5.30, German for Germans. 5.50, Weather and Announcements. 6.0, Transmission for all German Stations, relayed from Frankfurt. 7.0, To-day's motto. 7.5, Adventurous Travels—a Radio Sequence (Alfred Pringsel). 8.10, Request Concert on Gramophone Records. 9.0, Weather, News and Sports Notes. 9.30, Technical Wireless Talk. 9.45, Weather. 10.0, See Munich. 11.0 (approx.), Close Down.

BERLIN

FUNKSTUNDE, 716 kc/s, 419 metres; 1.5 kW. Relayed by Zeesen, DJC, DJA, DJD, DJB and DJE.—2.20 to 3.30 p.m., Programme for Women. 2.20, Talk: The Children's Nursery. 2.35, Elsa Ottingen Song Recital by Hete Mex (Soprano), accompanied by the Composer. 2.45, A Dialogue. 2.55, Extracts from the Wohltemperiertes Klavier (Bach) by Wilhelm Kempff (Pianoforte) on Gramophone Records: (a) Prelude and Fugue in D, (b) Prelude and Fugue in C Sharp. 3.10, Reading from the Letters of Nonne Marianna Alcorado. 3.30, Orchestral Concert relayed from the Haus Vaterland. 4.45, A Radio Sequence. 5.5, See Berlin (Deutschlandsender). 5.30, The Funkstunde informs its listeners. . . 5.45, Topical Talk. 6.0, Transmission for all German Stations, relayed from Frankfurt. 7.5, Concert by the Station Orchestra, conducted by Helmar Kähler: Overture, Im Herbst (Grieg); Symphonic Poem, Op. 41, Karpathen (Büder); Tanz unter der Dorfbrunne, Op. 161 (Reinecke); Serenade, Op. 48 (von Franckenstein). 8.0, Recital of Folk Songs. 8.20, Violin Concerto, Op. 35 (Tchaikovsky), by Erich Röhn and the Station Orchestra, conducted by Hans von Benda. 9.0, News and Sports Notes. 9.30, Gramophone Concert of Operetta Music: Overture, Der lustige Krieg (Joh. Strauss); Air from The Czarevitch (Lelhar); Air from The Geisha (Jones); Wenn zwei sich lieben from Der Rastelbinder (Lelhar); Tenor Aria from Don Cesar (Dellinger); Duet from The Gipsy Baron (Joh. Strauss); Selection from Liselott (Künneke). 10.0, Variety Programme relayed from the Open-Air Theatre at Gross-Glienicker See (on Gramophone Records). 11.0 (approx.), Close Down.

BERNE.—See Schweizerischer Landessender.

BEROMUNSTER.—See Schweizerischer Landessender.

BODEN.—See Stockholm.

BODO.—See Oslo.

BORDEAUX-LAFAYETTE

986 kc/s, 304 metres; 13 kW.—6.15 p.m., Radio Journal. 7.35, News. 7.40, Talk on Films. 7.55, Lottery Results. 8.0, Agricultural Programme. 8.15, News. 8.30, Concert of Light Music.

BRATISLAVA

1,073 kc/s, 279.5 metres; 14 kW.—4.55 p.m., Programme for Hungarian Listeners: Part I—Talk and Reading; Part II—Recital of Songs and Arias by Sagi Margit: Songs by Liszt, Zador and Stradella; Arias from Carmen (Bizet), Hérodiade (Massenet), Cavalleria rusticana (Mascagni), Samson and Delilah (Saint-Saëns) and Tosca (Puccini). 5.55, Hints for Housewives. 6.0, See Prague. 6.40, Recital of Jan Levoslav Bella Songs for the Composer's Ninetieth Birthday. 7.0, See Prague. 9.15 (approx.), Close Down.

BREMEN.—See Hamburg.

BRESLAU

923 kc/s, 325 metres; 60 kW. Relayed by Gleiwitz, 1,185 kc/s, 253.1 metres.—11.0 a.m., Weather. 11.5, Concert by the Silesian Philharmonic Orchestra, conducted by Gerhard Rischka: Overture, The Thieving Magpie (Rossini); Selection from Das Christlein (Pfitzner); Suite (Atterberg); German Dances (Urprung); Overture, Banditen-streiche (Süppé); Waltz, Op. 50, No. 2 (Schütt); Italian Suite (Kostal); Musikalische Dorfgeschichten (Kretschmer); Slow Waltz (Montey); March. In an interval at 12.45 p.m., Time, News and Exchange. 1.40, Programme arranged by the Post Office with Gramophone Records. 1.55, Agricultural Prices. 2.10, Talk: The Call of the Mountains. 2.30, Talk for Parents. 3.0, Orchestral Concert: Overture, Il Seraglio (Mozart); Waltz, Die Hydropathen (Gungl); Serenade, On Lake Maggiore (Heusser); Selection from The Serenade (Herbert); Intermezzo, Im Märchenwald (Römmfeldt); Potpourri, Diamanten und Perlen (Dostal); March (Maurer). 3.50, Talk: An Upper Silesian Labour Service Camp. 4.10, Agricultural Prices. 4.15 (approx.), Concert (contd.): March Sturmglöcken (Freitag); Overture to an Operetta (Lineke); Selection from Wiener Blut (Joh. Strauss); Ein Schäferstündchen (Siede); Potpourri, Waldteufel-Reigen (Weninger); Ull (Lark); Masquerade (Lindner). 5.0, Talk: Changing Names. 5.15, Radio Report from a Factory for Explosives. 5.40, Programme Announcements and Meat Market Prices. 6.0, Transmission for all German Stations, relayed from Frankfurt. 7.0, News. 7.10, Dance Music from the Südpark-Restaurant. 8.10, Die Huxst of Herr Hühlich-mühle—A Humorous Radio Play in Dialect (Schenke), with Music by Szcuka. 9.10, Time and News. 9.35, Gramophone Concert. 11.0 (approx.), Close Down.

BRNO

878 kc/s, 342 metres; 35 kW.—5.25 p.m., German Transmission: News, Talk on Gerhardt Hauptmann and Thomas Mann, and Talk for Workers. 6.0, See Prague. 6.40, A Lyric Play (Jichová). 7.5, See Prague. 9.30 (approx.), Close Down.

BRUSSELS (No. 1)

I.N.R., 589 kc/s, 509.2 metres; 15 kW.—12 Noon, Gramophone Records Acts I and II of Manon (Massenet). 1.0 p.m., Le Journal Parlé. 1.10, Concert by the Max Alexys Orchestra. 5.0, Concert by Robert de Kers and his Cabaret Kings, relayed from the Century Hotel, Antwerp. 6.0, Talk: The Origin of Life and of the World. 6.15, Gramophone Concert: Selection from Shulamith (Goldfaden); Träumerei (Schumann-Weiner); Selection from Lilac Time (Schubert-Berte); O sole mio (di Capua); Selection from Peter Pan (Crook). 6.45, O'Inventeur—Sketch (Lauville). 7.0, Gramophone Music: Melody (Tchaikovsky); Impressions d'Italie (Charpentier). 7.30, Medical Talk. 8.0, Musical and Literary Programme: Pianoforte Solo: Gaspard de la nuit (Ravel), by Carles Scharrès; Reading of Poems (Aloysius Bertrand), by Germaine la Vallée. 8.45, Song Recital by Yvette Guilbert. 9.30, Concert by Robert de Kers and his Cabaret Kings, relayed from the Century Hotel, Antwerp. 10.0, Le Journal Parlé.

BRUSSELS (No. 2)

N.I.R., 888 kc/s, 337.8 metres; 15 kW. Programme in Flemish.—12 Noon, Orchestral Concert. 1.0 p.m., Le Journal Parlé. 1.10, Gramophone Concert: Selection from The Gold-Diggers of 1933 (Warren); Les échos d'Alsace (Rucqoy); Waltzes (Romberg); Farewell to Naples (Cottrau); Selection from Princess Charming (Sirmay); Italian Fantasia (Delmas); Selection from Sunny (Kern). 5.0, Symphonic concertante for Violin and Viola (Mozart), on Gramophone Records. 5.30, Concert by the Radio Orchestra, conducted by Charles Walpot, with Commentary: Overture, Cigale et Magali (Casadesu); Two Lyric Rhapsodies (Coates); Musiquette for Pianoforte and Orchestra (Poot); Waltz for Two Saxophones (Bralsms); Serenade for Vibraplane and Orchestra (Saint-Saëns). 6.15, Talk: Pioneers of Free Thought in Belgium. 6.30, Concert (contd.): Rhapsody in Blue (Gershwin); Nocturne for Saxophone (Chopin); Suite, Four Ways (Coates). 7.30, Horticultural Review. 8.0, Béatrij's—A Musical Miracle Play (Veremans). In the interval, Recitation. After the Programme, Le Journal Parlé.

BUCHAREST

761 kc/s, 394 metres; 12 kW.—4.0 p.m., Popular Romanian Music by the Fania Luca Orchestra. In the interval at 5.0, Radio Journal. 6.0, Educational Talk. 6.20, Gramophone Music. 6.45, Talk. 7.0 to 8.45, Polish Programme. 7.0, Talk on Poland. 7.20, Concert by the Station Orchestra: A Lithuanian Rhapsody (Karlo-wicz); Elegy (Moniuszko); Valse brillante (Chopin). 7.50, Recital of Polish Poetry. 8.0, Recital of Polish Songs by Dora Masini. 8.20, Sonata for Pianoforte and Violin (Szymanowski), by Alfred Alessandresco and Alexandre Theodoresco. 8.45, Radio Journal.

BUDAPEST

545 kc/s, 550.5 metres; 18.5 kW.—Also relayed on 840 metres from 6.30 p.m. till Close Down.—4.30 p.m., Concert. 5.0, Italian Lesson. 5.25, Gramophone Music. 6.30, Der Dichter—Play in Three Acts from the Life of Karl Kisfaludy (Michael Boross). 8.15, News. 8.30, Concert of Cigány Music from the Café Baross. 9.30, Concert. 10.15, Dance Music from the Café Baross.

CASSEL.—See Frankfurt.

COPENHAGEN

1,067 kc/s, 281 metres; 0.75 kW. Relayed by Kalundborg, 260 kc/s, 1,153.8 metres, and Skamlebaek, OXY, 49.4 metres.—11.45 to 1.0 p.m., String Ensemble Concert, relayed from the Bellevue Strandhotel. 1.30, Programme for Women. 2.0, Concert by the Teddy Petersen Orchestra, relayed from the Vivex Restaurant. 4.0, Gramophone Music. 4.30, Exchange and Fish Market Prices. 4.45, Medical Talk. 5.15, French Lesson. 5.45, Weather and Announcements. 6.0, News. 6.15, Time. 6.30, Review of Important Events of November. 7.0, Chimes from the Town Hall. 7.5 Fall Concert by the Radio Orchestra, conducted by Emil Reesen; March and Waltz from The Dollar Princess; Selection from The Rose of Stamboul; Bräderleif; Selection from Roses from Florida. 7.45, Talk. 8.15, Scheibe Harpsichord Recital by Folmer Jensen: Sonata No. 1 in C; Sonata No. 2 in G. 8.35, Reading (Soslulja). 9.0, News. 9.15, Concert by the

Radio Orchestra, conducted by Emil Reesen: In the Steppes of Central Asia (Borodin); Orientale (Cui); Spanish Serenade (Glazunov); Arab Melody (Glazunov); Piedmontese Folk Dance No. 1 (Sinigaglia); Gopak (Mussorgsky); Extract from the Japanese Suite (Holst). 10.0, Dance Music, relayed from Nimb's Restaurant. In the interval at 11.0, Time and Chimes from the Town Hall. 11.30 (approx.), Close Down.

CORK.—See Athlone.

DANZIG.—See Heilsberg.

DRESDEN.—See Leipzig.

FECAMP

1,328 kc/s, 225.9 metres; 10 kW.—11.0 a.m. till 12 Noon, Programme in English by the I.B.C. 11.0, Happy Hour. Request Music: Signature Tune; Hand me down my Walking Cane; Rhapsody in Blue (Gershwin); Bless this House (Taylor); Poissonaise in A (Chopin); Song of the Nightingale (Albouth); Vilkins and his Dinah (Traditional); You've got me crying again (Newman); Sweetheart Darlin' (Kahn); Everything that's nice; Minnie the Moocher; Mary Jane; Just a Little Smile; Ho Hum; Wear a Great Big Smile (Gilbert); I'll see you in the Morning (Fields); Dance Pretty Lady (Strauss); Signature Tune. 12 Noon, Programme in French. 3.30 to 6.0 p.m., Programme in English by the I.B.C. 3.30, Hawaiian Band: Tango des Roses (Scherler); Naughty Hawaii (Carlo); Hawaiian Waltzes; Caru mia (Brodsky); Aloha Oe (Lilioukalani); Maui Girl (Liborina); La Rosita (Dupont); My South Sea Home (Camillio). 4.0, Dance Music: Signature Tune, The Bells of Normandy; Lay your Head on my Shoulder; Dinner at Eight; Moths around the Candle Flame; Mon amour; Gipsy sing for me; Everyone loves my Marguerite; Tick, Toek; Isn't this a Night for Love; Signature Tune, The Bells of Normandy. 4.30, The I.B.C. Nursery Corner Birthday Greetings; Trumpets. 4.40, Orchestral Concert for Isle of Wight Listeners: Signature Tune, The Night by the Sea; Waltz Medley (arr. Simpkin); The Coon among the Chickens (Ives); Pianoforte Solo: Hollyhock (Mayer); Sizzilietta (Blon); Love and Life in Vienna (Renard); Her first Dance (Heykens); The Busy Bee (Bendix); The Futuristic Rag (Bloom); Vocal: Forty-Second Street (Dubin); Memories of Paris (Christine). 5.20, Portsmouth and Southsea Concert of Military Music: Trumpets; Down South (Myddleton); Selection from The Miracle (Humperdinck); The Hunt in the Black Forest (Eitelberg); The Skaters' Waltz (Waldteufel); Song, Invictus (Huhn); March (Mohr); The Mad Major (Alford); Corset Solo: Carnival of Venice (Briccialdi); Ständchen (Heykens); In a Persian Market (Ketelbey); The Doge's March (Rosse); Signature Tune. 6.0, Programme in French. 10.0 (approx.) till Close Down. Programme in English by the I.B.C. 10.0, Light Music: Out of Breath; Song, Castles in the Sand (Saudford); Pianoforte Solo: The Birth of the Blues (Henderson); Egyptian Serenade, Amina (Lincke); Song, Don't be late in the Morning (Le Clercq); Sweetheart I'm dreaming of you (Desmond); Song, Sundown in a Little Green Hollow (Buckette); Romance (Lohr). 10.30, Dance Music: Signature Tune, The Bells of Normandy; Let the World go drifting by; P.C. 123; Love Songs of the Nile; Who's Afraid of the Big Bad Wolf; Ah! but it's Love; Sweetheart Darlin'; From me to you; Sweep; Signature Tune, The Bells of Normandy. 11.0, Talkie Time. Tunes from the Talkies and Shows: Signature Tune, Sittin' in the Dark; Selection from The Kid from Spatht (Kalmar); Sweep (Ellis); In a Year, in a Day (Heymann); Peter (Hollander); A Couple of Fools in Love (Valentine); Selection from Il est charmant (Moretti); Why has a Cow got Four Legs? (Ellis); Dancing on the Ceiling (Hart); Signature Tune. 11.30, Club Concert for Llanwryd Wells Listeners. Part I, Orchestral Concert: Signature Tune, The Chum Song, Musical Comedy Switch (arr. Hall); Ideale (Tosti); March of the Men of Harlech; Pizzicato from Sylvia (Delibes); Artist's Life (Joh. Strauss); Cavatina (Raff); Cymru Eys (Perry); Air de Ballet (Heubert). 12.5 a.m. (Thursday), Late News Bulletin in English. 12.10 (approx.), Club Concert: Part II: Stay out of my Dreams (Washington); The Wedding of Mr. Micky Mouse (Pola); The Last Round Up (Hill); Lover (Rougiers); The Three Trees (Powell); Signature Tune. 12.30, Dance Music: Signature Tune, The Bells of Normandy; I've got to sing a Torch Song; My Moonlight Madonna; Nanea; About this Time next Week; A couple of Fools in Love; Well Done Gordon; I'm getting Sentimental over you; For Love Time. 1.0, Dance Music: Smoke Rings; Nana; Gofius; I've got to get up to go to work; If you'll say Yes; Chérie; Oh, Johanna; My Own; Love in the Moonlight; A couple of Pals; Conchita; It's the Talk of the Town; Isn't it Heavenly; Ding, Dong, Ding; Lazybones; Nobody's Sweetheart; Out in the Open; Signature Tune, The Bells of Normandy. 2.0, I.B.C. Good-night Melody and Close Down.

FLENSBURG.—See Hamburg.

FLORENCE.—See Turin.

FRANKFURT

1,157 kc/s, 269.3 metres; 17 kW. Relayed by Cassel and Trier, 1,157 kc/s, 259.3 metres.—12.15 p.m., Time and News. 12.25, Local News and Weather. 12.35, See Stuttgart. 1.30, A Radio Play for Children. 2.30, Weather Forecast. 2.40, Time and Market Prices. 3.0 to 5.35, See Langenberg. 5.35, Topical Programme. 5.50, Weather, News and Time. 6.0, Transmission for all German Stations: Florestan and Eusebius—The Struggle of the Davidstünder for Art against the Philistines; Musical Radio Sequence after Schumann. 7.0, Topical Programme. 7.10, See Stuttgart. 9.0, Time and News. 9.20, See Stuttgart. 9.30, Local News and Weather. 9.45, Gramophone Concert. 10.0, Scenes from Mozart's Life—Play in One Act, with Music by Mozart, arranged by Lortzing. 11.0, Concert. 12 Midnight, Close Down.

FREDERIKSTAD.—See Oslo.

FREIBURG.—See Stuttgart.

GENEVA.—See Radio-Suisse Romande.

GENOA.—See Turin.

GLEIWITZ.—See Breslau.

GOTEBORG.—See Stockholm.

GRAZ.—See Vienna.

HAMAR.—See Oslo.

HAMBURG

806 kc/s, 372 metres; 1.5 kW. Relayed by Bremen, 1,112 kc/s, 269.8 metres; Flensburg, and Hanover, 1,319 kc/s, 227.4 metres; and Kiel, 1,292 kc/s, 232.2 metres.—3.0 p.m., Concert by the Small Station Orchestra, conducted by Adolf Secker. Overture, Rosamunde (Schubert); Consolation No. 2 (Liszt); Suite, No. 1 from L'Arlesienne (Bizet); Overture, Prince Igor (Borodin); Selection from Die toten Augen (d'Albert); Entry of the Boyards (Halvorsen). 4.0 (from Kiel). The Actress—Play (Friedrich von Hebbel). 4.30, Gramophone Records for Children. 4.50, A Humorous Radio Sequence for Children (Walter Gullke), with Songs to the Tune by Richard Genner. 5.40, Frankfurt Exchange and Hamburg Market Prices. 5.50, Weather. 6.0, Transmission for all German Stations, relayed from Frankfurt. 7.0, The Magic Cabinet—A Musical Play for Radio (Walter Hapke). 9.0, Time and News. 9.20, Orchestral Concert, relayed from the Reichshof. 10.10, Relay of a Concert.

HANOVER.—See Hamburg.

HEILSBURG

1,085 kc/s, 276.5 metres; 60 kW. Relayed by Danzig, 671 kc/s, 447.1 metres.—12.5 p.m., German Rivers—Gramophone Concert: An der Weser (Pressel); Moonlight on the Danube (Gay); Am Rhein (Overzier); Moonlight on the Alster (Petras); Moseleintick (Korn); Herrgott, am blühenden Neckarstrand (May); Am Kolbenzer Eck (Czemik); Alt Marburg an der Drau (Frank); Denn im blühenden, lachenden Moseltal (Spies); An der schönen grünen Isar (Freundorfer). In the intervals at 12.20 and 1.0, News. 1.10, Concert by a Trombone Ensemble: Wachet auf, ruft uns die Stimme (arr. Praetorius); Nun lob mein Seel den Herrn (Kugelman); Folk Song, In stiller Nacht zur ersten Wacht; Treue Liebe bis zum Grabe (Handel); Folk Song, Ich fahr dahin; O du mein Trost und süßes Hoffen (Frank); Macht hoch die Tür die Tor macht weit (Halle). 1.30 (approx.), Programme arranged by the Post Office with Gramophone Records. 2.0, Agricultural Prices and Exchange. 2.20, Hints for the Housewife. 3.0, Concert by the Königsberg Opera House Orchestra, conducted by Wolfgang Brückner: Selection from Lisola disabitata (Haydn); The Brandenburg Concerto No. 3 in G (Bach); German Folk Song Fantasia (Blumer); Spielmusik (Weiss); Four Old Dances (Niemann); Overture, L'amore medico (Wolf-Ferrari). 4.30 (from Danzig). Talk. 4.50, Review of Periodicals. 5.15, Agricultural Prices. 5.25, Talk: The Art of Pianoforte Playing, with Illustrations from the Music of Brahms. 5.50, Weather. 6.0, Transmission from all German Stations, relayed from Frankfurt. 7.0, News. 7.10, Dance Music by the Small Station Orchestra, conducted by Eugen Wilcken. 9.0, News. 9.15 (approx.), Concert. 11.0 (approx.), Close Down.

HILVERSUM

1,013 kc/s, 296.1 metres; 7 kW, up to 5.40 p.m.; and 20 kW from 5.40 p.m.—14.40 a.m. till Close Down. Programme of the Workers' Radio Society (V.A.R.A.). 11.40, Concert by the Small V.A.R.A. Orchestra, conducted by de Groot: Marche des gamins de Paris (Berger); Réve (d'Ambrosio); Lolita (Buzzi-Peccia); Serenade (Jensen); Melody (Rubinstein); Chanson d'automne (Tchaikovsky); Motor March (Rosey); Gramophone Records: Marche russe (Ganne); Valse triste (Børgen); Patrouille lointaine (Gillet); Ständchen (Schubert); Three O'clock in the Morning (Robledo); Vienna, City of my Dreams (Sieczynski); Petite marche viennoise (Kreialer); Gramophone Records: Le Jongleur (Rosey); Waltz, Op. 54, No. 1 (Dvorak); Serenade (Pierné); The Holy City (Adams); Troika (Steinberg); Si j'étais jardinier (Chaminade); Réve angelique (Rubinstein); Los banderillos (Volpatti). 1.40 p.m., Interval. 1.55, Dressmaking Lesson. 2.40, Pro-

NOV. 29th WEDNESDAY continued

gramme for Children. 5.40, Concert by the V.A.R.A. Orchestra, conducted by de Groot: Overture, Nakiris Hochzeit (Lincke); Waltz (Nedbal); Chinese Tea-House (Hertz); Viennese Waltz (Benatzky); Ein Souper bei Suppe (Morena). 6.10, Talk: The League of Nations. 6.40, Talk. 7.0, Concert of Light Music. 7.20, Recitation. 7.40, SOS Announcements. 7.42, Concert by the V.A.R.A. Orchestra, conducted by de Groot: Kamarinskaya (Glinka); Hymn to the Sun (Rimsky-Korsakov); Five Russian Dances (Bortkiewicz); Chanson triste (Tchaikovsky); Extract from the Sleeping Beauty (Tchaikovsky). 8.30, News and Announcements. 8.40, Orchestral Concert, conducted by Ruyrok: Soloists; Nelles (Songs) and Stotijn (Oboe); The Pathetic Symphony (Tchaikovsky); Five Songs; Overture, The Hebrides (Mendelssohn); Oboe Concerto (Haydn); Three Songs; Romeo and Juliet (Tchaikovsky). 10.40, Organ Recital by Jong: Selection from The Geisha (Jones); Dancing Butterflies (Pettere); Melody (Delettre); The Wedding of the Diagonfies (Reaves). 11.10, Gramophone Records. 11.40 (approx.), Close Down.

HORBY.—See Stockholm.

HUIZEN

160 kc/s, 1,875 metres; 7 kW. until 3.40 p.m. Transmitted from Kootwijk on 50 kW. from 3.40 p.m.—11.55 a.m. till Close Down. Programme of the Christian Radio Society (N.C.R.Y.). 11.55, Gramophone Music. 12.10 p.m., Concert by the Van de Horst Trio and Mme. Ravenzwaay-Möllenkamp (Songs): Trio in A Minor (Buxtehude); Three Pieces (J. W. Franck): (a) Welt ist Welt, (b) Gebet um Seelenfrieden, (c) Lebenstrost; Bundeslied (Mozart); Im Frühling (Mozart); Aria from Alcina (Handel); Aria from Figaro (Mozart); Aria from Iphigenia in Aulis (Gluck); Gramophone Records: Gebet vor der Schlacht (Weber); Pilgerspruch (Mendelssohn); Chanson triste (Tchaikovsky); Een lied (Weiss); Herfst (de Coq); Gelderland Folk Song (Rombout v. Riemsdyk); Aan Brabant (Maassen); Kind van Holland (Moolenaar); Holder Friede (Romberg); La musica proibita (Gastaldon). 1.40, Gramophone Music. 2.10, Talk for Women. 2.40, Religious Talk. 3.10, Gramophone Music. 3.25 to 3.40, Interval. 3.40, Organ Recital by Klok: Legend, Op. 6, No. 1 (Melartini); Sons les branches, Op. 16, No. 1 (Lazzari); Marche Sainte (Massenet); Au matin; Op. 43 (Godard); An convent (Borodin); Au Genfer See, Op. 130 (Bendel). 4.40, Programme for Children. 5.40, Agricultural Talk. 6.10, Programme to be announced. 6.40, Police Notes. 6.55, Religious News. 7.10, Talk on Russia. 7.40, Divine Service, relayed from the Baptist Church in Hengelo. 9.10, News. 9.20, Organ Recital by Zwart. 10.20, Gramophone Music. 11.10 (approx.), Close Down.

INNSBRUCK.—See Vienna.

JUAN LES PINS

1,205 kc/s, 249 metres; 0.8 kW.—8.0 p.m., Amusement Gable, Financial Report, Exchange and News. 8.10, Concert. In the interval at 9.0, Announcements and Weather.

KALUNDBORG.—See Copenhagen.

KIEL.—See Hamburg.

KLAGENFURT.—See Vienna.

KOSICE.—See Prague.

LANGENBERG

635 kc/s, 473 metres; 60 kW.—12.25 p.m., News and Weather. 12.35, Concert from Stuttgart. 1.30, See Frankfurt. 2.30, Market Prices. 2.50, Political Announcements. 3.0, Concert. Part I. Dance Music. Part II. Humorous Programme. Part III. Choral and Orchestral Music. 5.0, German for Germans. 5.20, Talk on Race Origins. 5.35, Report on Research Work and Science, with Musical Interludes. 5.50, Announcements. 6.0, Transmission for all German Stations, relayed from Frankfurt. 7.0, See Frankfurt. 7.10, See Stuttgart. 9.30, News and Sports Report. 9.45, See Frankfurt. 11.0, Concert. 12 Midnight, Close Down.

LAUSANNE.—See Radio-Suisse Romande.

LEIPZIG

770 kc/s, 389.6 metres; 120 kW. Relayed by Dresden, 941 kc/s, 319 metres.—11.0 a.m., Concert by the Leipzig Symphony Orchestra, conducted by Hilmar Weber. Overture, The Magic Flute (Mozart); Ballet Music from Anacreon (Cherubini); Selection from Le Postillon de Lonjumeau (Adam); Andante and Humoresque from the Suite, At Carnival Time (Georg Schumann); Extract from The Damnation of Faust (Berlioz); Overture, Edelweiss (Komzak); Selection from La Dame blanche (Boieldieu); Isa-Walzer (Graller); Selection from Der Sternruker (Léhar). In the interval at 12.15 p.m., News and Programme Announcements. 1.15, to 1.30, News. 2.0, Gramophone Music. 2.35, Market Prices. 3.0, Recital of Folk Songs

by a Students' Choir. 4.0, Book Review. 4.20, Topical Programme. 4.35, Vocal and Instrumental Concert: Ruth Meister (Violin); Felix Möller (Baritone). Fritz Römischi (Cello), and Alf Nestmann (Pianoforte). March and Minuet from the Suite, Carnival (Kienzl); Two Songs (Goltermann): (a) Albumblatt, (b) Melody, (c) Humoresque; Adagio, Op. 57, for Violin and Pianoforte (Hillmann); Pianoforte Solo: Extract from Preludes, Op. 21 (Scalero). 5.15, Talk: Remains of Celtic and Germanic Temples in Trier. 5.40, Market Prices and To-day's News. 6.0, Transmission for all German Stations, relayed from Frankfurt. 7.0, Gramophone Records. 7.30, Variety Programme. 9.0, News and Sports Notes. 10.0, Dance Music by the Emde Orchestra. 11.0 (approx.), Close Down.

LINZ.—See Vienna.

LJUBLJANA

522 kc/s, 574.7 metres; 7 kW.—6.0 p.m., Topical Talk. 6.30, Literary Talk. 7.0, Relay from the Opera House. In the interval, Weather and News.

LUXEMBOURG

252 kc/s, 1,191 metres; 200 kW. Luxembourg Evening. 7.0 p.m., Talk on Art. 7.35, Gramophone Music: Overture, The Gipsy Baron (Joh. Strauss); Quadrille (Metra); Polish Festival from Le roi malgré lui (Chahrier). 8.0, Recital of Songs. 8.30, News in French. 8.45, See Radio-Paris. In the interval at 9.30 (approx.), News in German. 10.30, Dance Music on Gramophone Records.

LYONS

LA DOUA, 644 kc/s, 465.8 metres; 3 kW.—7.40 p.m., Radio Gazette for Lyons and the South East. 8.30, Choral and Instrumental Concert relayed from the Salle Mollière. Soloists: Alexis Ticier (Cello), Mme. Lysiane Doriani (Songs) and Jean Bouvard (Organ). After the Concert, News Bulletin.

MADRID

ARANJUEZ (EAO), 10,000 kc/s, 30 metres; 20 kW.—10.30 p.m., Concert of Popular Music. In the interval at 10.45, Radio Chronicle. 11.45, Light Music. 12 Midnight till Close Down, Concert arranged by the International Broadcasting Company (Ireland), Ltd. Signature Tune: Come Back to Erin. Selection from The Land of Smiles (Léhar); Selection from Viktoria and her Hussar (Abraham); My Beautiful One (Rondot); There's a House on a Hill (Meyer); Hawaiian Waltz Medley (Traditional); Waltz and March from The Vagabond King (Friml); Signature Tune: Come Back to Erin. 12.30 a.m. (Thursday), I.B.C. Good-night Melody and Close Down.

MADRID

EAJ7, 707 kc/s, 424.3 metres; 2 kW.—7.0 p.m., Chimes, Exchange, Topical Talk, Dance Music and Talk by Ramón Gómez de la Serna. 8.15, Topical Review. 8.30 to 9.30, Interval. 9.30, Chimes, Time and Radio Journal. 9.45 (approx.), Concert by the Madrid Philharmonic Orchestra, conducted by Pérez Caas. 11.45, Radio Journal. 12 Midnight, Chimes, and Close Down.

MALMO.—See Stockholm.

MILAN.—See Turin.

MORAVSKA-OSTRAVA

1,137 kc/s, 263.8 metres; 11 kW.—3.0 p.m., Concert by the Station Orchestra, conducted by Plichta. Soloist: Albert Burisk (Flute); Selection from Samson and Delilah (Saint-Saëns); Flute Concertino (Chaminade); Extracts from the Suite, Impressions d'Italie (Charpentier); Overture, Le roi l'a dit (Delibes). 3.50, See Prague. 4.35, Recitations. 4.50, Gramophone Music. 5.0, Market Reports. 5.5, Talk. 5.15, See Prague. 5.25, Cello Recital by Blazek. 6.0, See Prague. 6.10, Talk for Soldiers. 6.25, See Prague. 6.40, Schrammel Quartet Concert. 7.0, See Prague. 9.15 (approx.), Close Down.

MOSCOW

KOMINTERN (RWI), 202.5 kc/s, 1,481 metres; 500 kW.—3.15 p.m., Musical Programme. 3.30, Educational Talk. 4.30, Red Army Programme. 5.30, Programme for Workers on Collective Farms. 6.30, Talk on Culture and Technics. 7.0, Extracts from Figaro—Opera (Mozart). 8.0, Radio Film in German. 8.55, Chimes from the Red Square. 9.5, Lecture in English by D. S. Mirsky: Soviet Literature, III. 10.5, Review of the Month in Czech.

MOTALA.—See Stockholm.

MUHLACKER.—See Stuttgart.

MUNICH

563 kc/s, 533 metres; 1.5 kW. Relayed by Augsburg and Kaiserslautern, 536 kc/s, 560 metres; and Nürnberg, 1,256 kc/s, 239 metres. 3.30 p.m., Concert by the Small Station Orchestra, conducted by Karl List: Overture, The Secret Marriage (Cimarosa); Suite,

Errotiken (Jensen); Minnet from Falstaff (Verdi); Selection from La Roudine (Puccini); Waltz, Blonde or Brunette (Waldteufel); Miniatures (Cui); Scherzo (R. Strauss); Intermezzo from Si (Mascagni). 4.45 (from Nürnberg), Talk: German Troops in India in the Eighteenth Century. 5.5, Organ Recital by Edouard Kiesel: Two Preludes (Heller); Consolation No. 5 (Liszt); Intermezzo (Rheinberger); Improvisations. 5.25, Talk on Trades: The Upholsterer. 5.45, Time, Weather and Agricultural Report. 6.0, Transmission for all German Stations, relayed from Frankfurt. 7.0, Bavarians in America—A Radio Sequence (Josef Wanneringer). 7.45, In der Nacht, in der Nacht... —A Suite by the Station Dance Band, with Commentary. 9.0, Time and News. 10.0, Serenade by the Small Station Orchestra, conducted by Karl List. 11.0 (approx.), Close Down.

NAPLES.—See Rome.

NOTODDEN.—See Oslo.

OSLO

277 kc/s, 1,083 metres; 60 kW. Relayed by Fredrikstad, 815 kc/s, 368.1 metres; Hamar, 522 kc/s, 574.7 metres; Notodden, 671 kc/s, 447.1 metres; Porsgrund, 662 kc/s, 453.1 metres; and Rjukan, 671 kc/s, 447.1 metres; and Jeløy, LCL, 6,990 kc/s, 42.92 metres.—4.0 p.m., Gramophone Concert. 5.0, French Lesson. 5.30, Programme for Girls. 6.0, Announcements, Weather and News. 6.30, Talk: The Origin of the Old Testament. 7.0, Time Signal. 7.1, Chamber Music by the Danish Quartet. Erling Biech (Violin), Knud Pedersen (Violin), Hans Kassarow (Viola), Lützholtz (Cello). String Quartet in F (Nielsen); Quartet in G (Haydn). 8.0, Recitations. 8.30, Agricultural Report. Weather and News. 9.0, Topical Talk. 9.15, Concert by the Station Orchestra, conducted by Kramm: Suite for String Orchestra, Aus Holbergs Zeit (Grieg); Two Pieces (Sinding); (a) Soir, (b) Waltz; Norwegian Rhapsody No. 1 (Halvorsen). 10.0, Dance Music on Gramophone Records. 11.0 (approx.), Close Down.

OSTERSUND.—See Stockholm.

PALERMO

556 kc/s, 539.5 metres; 3 kW.—7.0 p.m., Dopplavoro Announcements, Tourist Talk, Agricultural Notes and Giornale Radio. 7.20, Gramophone Music. 7.30, Time and Announcements. 7.45, Orchestral Concert; Soloists: Costanza Notarbartolo (Soprano) and Saporettili (Violin); Allegro (Haydn); Soprano Solos; Andante (Mendelssohn); Violin Solos: (a) Air on the G String (Bach), (b) Allegro from the Sonata in G (Leclair); Soprano Solos; Turkish March (Mussorgsky); Violin Sonata in A (Porpora); Passo delle vecchie dame, from the Concerto Veneziano (Casella). In the interval, Talk. After the Concert, Gramophone Music. 10.0, Giornale Radio.

PARIS

EIFFEL TOWER, Call FLE, 207.5 kc/s, 1,445.7 metres; 13 kW. Time Signals (on 2,650 metres) at 9.26 a.m. and 10.26 p.m. (Preliminary and 6-dot Signals).—5.45 p.m., Le Journal Parlé. 7.15, Weather. 7.25, Political Review. 7.45, Programme for Children. 8.15, Orchestral Concert, conducted by Flament: Spanish Caprice (Rimsky-Korsakov); Italian Caprice (Tchaikovsky); Norwegian Rhapsody (Lalo); Slav Festival (Glazunov). 9.0 (approx.), Close Down.

PARIS

POSTE PARISIEN, 914 kc/s, 328.2 metres; 60 kW.—7.0 p.m., Classical Music on Gramophone Records. 7.15, Journal parlé. 7.50, Light Music on Gramophone Records. 7.55, Talk on Economics. 8.0, Concert. 8.45, Interval. 9.5, Scenes from the Revue, Ici Paris, relayed from the Théâtre de Nouveautés. 10.30, Orchestral Concert, relayed from the Restaurant des Champs-Élysées. 11.0, News.

PARIS

RADIO-PARIS; Call CFR 174 kc/s, 1,725 metres; 75 kW.—6.45 a.m., Physical Culture. 7.30, Weather and Physical Culture (contd.). 7.45, Gramophone Music. 8.0, Press Review and Weather. 12 Noon, Educational Talk. 12.15, Gramophone Music. 12.30, Organ Recital by Desserre, relayed from the Gaumont Palace; Extracts from Peer Gynt (Grieg); Melodies from The Gold Diggers (Warren). 1.0 p.m., Exchange and News. 1.5, Gramophone Concert of Opera Music: Overture, The Caliph of Baghdad (Boieldieu); Selection from: (a) Les dragons de Villars (Maillart-Tavau), (b) Les noces de Jeannette (Massé); Overture, La princesse jaune (Saint-Saëns); Overture, Gwendoline (Chabrier); Overture, Zampa (Hérold-Winter); Overture, Fra Diavolo (Auber); Selection from Si j'étais roi (Adam). 2.0 and 3.45, Exchange. 6.20, Agricultural Talk. 6.45, Book Review. 7.0, Medical Talk. 7.20, Dance Music, Old and New: Le quadrille des Lanciers (Metra); Fascination (Marchetti); Loin du bal (Gillet); Golliwog's Cake Walk (Debussy); La Tzarine (Ganne); Foxtrot, Miami (Lears); Tango, Tu n'es plus rien (Markush); Java des as (Marceau). 8.0, Reading. 8.30, News and Weather. 8.40, Fashion Review. 8.45, Concert by the Lamoureux Concert Society,

conducted by Albert Wolff: Suite in D (Bach); Prélude à l'après midi d'un faune (Debussy); Piano-forte Concerto No. 2 in G Minor (Saint-Saëns); Shéhérazade (Rimsky-Korsakov). In an interval at 9.15, Press and News.

**PITTSBURGH**

**KDKA**, 980 kc/s, 306 metres; 50 kW. Relayed by **W8XK** on 48.66 metres and 25.27 metres.—7.0 p.m., Musical Originalities, from New York. 7.30, KDKA Home Forum. 8.0, Southern Symphonies, from New York. 8.15, Happy Days in Dixie, from New York. 8.45, Human Values. 9.0, Betty and Bob, from New York. 9.15, Utility Hall. 9.30, Frances Ingram. 9.45, News and Market Reports. 10.0, Uncle Tom and Betty. 10.15, KDKA Kiddies' Klub. 10.30, Singing Lady, from New York. 10.45, Drphan Annie, from New York. 11.0, News, Pay Haley. 11.15, Sports and Programme Review. 11.30, Evening-song. 11.45 to 3.30 a.m. (Thursday), New York Relay. 11.45, Lowell Thomas. 12 Midnight, Ainos 'n' Andy. 12.15, Gems of Melody. 12.30, Potash and Perlmutter. 12.45, Irene Rich for Welch. 1.0, Crime Clues. 1.30, Dangerous Paradise. 1.45, Red Davis. 2.0, Warden Lawes. 2.30, John McCormack and Orchestra. 3.0, Pedro Via's Orchestra.

**PORSGRUND**.—See Oslo.

**PRAGUE**

614 kc/s, 488.6 metres; 120 kW.—3.0 p.m., See Moravská-Ostrava. 3.50, Programme for Children. 4.35, Gramophone Records. 4.45, Talk. 4.55, Gramophone Records. 5.5, Agricultural Talk. 5.15, Talk for Workers. 5.25, News in German. 5.30, German Transmission: Talk for Workers and Labour Market Report. 6.0, Time Signal, News and Weather. 6.10, Advanced French Lesson. 6.25, Talk on Economics. 6.40, See Bratislava. 7.0, Talk on the following Transmission. 7.5, Suk Concert, relayed from the Smetana Hall. Conductor: Vaclav Talich: Meditation on the Choral St. Wenceslaus, Op. 35a, for String Orchestra; The Legend of Dead Victors; Symphonic Poem, Harvest-tide. In an interval, Recitation. 9.0, Time, News, Review of the Day, and Sports Notes. 9.15, News in French. 9.30 (approx.), Close Down.

**RADIO-SUISSE ROMANDE**

**SOTTENS**, 743 kc/s, 403 metres; 25 kW.; and Geneva, 400 kc/s, 749.9 metres.—6.0 to 6.15 a.m. (from Lausanne), Gymnastics. 11.28, Time Signal from Neuchâtel Observatory. 11.30, News and Weather. 11.40 (from Geneva), Gramophone Concert. 12 Noon (from Geneva), Financial Notes. 12.10 p.m. (from Geneva), Gramophone Concert (contd.). 1.0, Interval. 2.58, Time Signal from Neuchâtel Observatory. 3.0, See Schweizerischer Landessender. 5.0 (from Lausanne), Programme for Children. 6.0 (from Geneva), Monthly Science Review. 6.30 (from Geneva), Radio Chronicle. 6.59, Weather Report. 7.0 (from Geneva), A Musical Medley by Mlle. Laure Choisy. 7.10 (from Geneva), Travel Stories. 7.30 (from Geneva), Bach Concert by the Radio-Suisse romande Orchestra, conducted by Francis Bodet, relayed from the Temple de Saint-Gervais. Soloists: Gabrielle Bodet (Soprano), Nelly Gretillat (Contralto), Ernest Bauer (Tenor), Joseph Lombard (Bass), Reichel (Organ) and Charles Koller (Harpichord). 9.0 (approx.), News and Weather. 9.10 (from Geneva), Talk: The Work of the League of Nations. 9.30 (approx.), Close Down.

**REYKJAVIK**

250 kc/s, 1,200 metres; 21 kW.—8.0 p.m., Musical Programme. 8.10, Weather. 8.20, Musical Programme and Announcements. 8.35, Programme to be announced. 9.0, Chimes. 9.2, Violin Solos by Thorarinn Gudmundsson. 9.30, Reading. 10.0, News. 10.30, Extracts from Der Rosenkavalier (Richard Strauss) on Gramophone Records.

**RIGA**

371 kc/s, 525.3 metres; 15 kW.—6.0 p.m., Weather Report. 6.5, Concert of French Music, conducted by Medius. Soloist: Adolfs Kaktins (Songs). Petite Suite (Debussy); Songs: (a) Soir (Gounod), (b) Rosanna (Granier), (c) Elégie (Massenet), (d) Danse macabre (Saint-Saëns); Suite from Padmavati (Roussel). 7.5, News. 7.25, Night in Music—Orchestral Concert, conducted by Medius: Serenade (Goldmark); Clair de lune (Chopin); Night in a Moorish Café (Humperdinck); Cortège nocturne (Ravel); Serenade (Nicodé); Nocturne (Grieg); Bonne nuit, bien-aimée (Sibelius). In the interval at 8.0, Weather and News. 8.35, Dance Music. 9.30 (approx.), Close Down.

**RJKUKAN**.—See Oslo.

**ROME**

Call **1RO**, 680 kc/s, 441 metres; 50 kW. Relayed by Naples, 941 kc/s, 319 metres; Milan (Vigentino), 662 kc/s, 453.1 metres from 7.30 p.m.; and **2RO**, 11,810 kc/s, 25.4 metres.—12 Noon to 1.15 p.m., Orchestral Concert. In the intervals at 12.30, Giornale Radio and Exchange, and at 1.0, Time and Announcements. 3.30, Children's Radio Review. 3.55, Giornale Radio, Exchange, and Report of the Royal Geographical Society. 4.10, Weather Forecast. 4.15 to 5.0, Orchestral Concert: A Honeymoon Trip (May); Rondio-

NOV. 29th **WEDNESDAY** continued

Caprice (Beethoven); Melody (Abel); Berceuse (Culotta); Selection from Le belle di notte (Cuscina); Waltz in a Dream (Crosby); O Cele o Celestina (Maresca). 5.40 (Naples), Shipping and Sports Notes. 5.45, Dopolavoro Announcements and Tourist Report. 5.57, Report of the International Institute of Agriculture (in Italian and English). 6.10, Agricultural Notes and Wheat Market Report. 6.20, News in Foreign Languages. 6.40, Giornale Radio. 7.0, Time, Announcements, and Gramophone Music. 7.15, See Turin. 7.30, Tristan and Isolde—Opera in Three Acts (Wagner). In the intervals, Talk and Announcements. After the Programme, Giornale Radio.

**SALZBURG**.—See Vienna.

**SCHENECTADY**

**WGY**, 790 kc/s, 379.5 metres; 50 kW. Relayed at intervals by **W2XAF** on 31.48 metres and by **W2XAD** on 19.56 metres.—7.30 to 8.30 p.m. (approx.), Milady's Matinée, from New York. 12.45 a.m. (Thursday), Trials of the Goldbergs, from New York. 1.0, Popular Programme. 1.30, Variety Programme. 2.0 to 3.30, New York Relay. 2.0, Ipana Troubadours. 2.30, Phillip Morris Programme. 3.0, Variety Programme. 3.30, National Radio Forum, from New York, followed by Programme Résumé.

**SCHWEIZERISCHER LANDESENDER**

**BEROMUNSTER**, 653 kc/s, 459 metres; 60 kW.; Basle, 1,229 kc/s, 244.1 metres; and

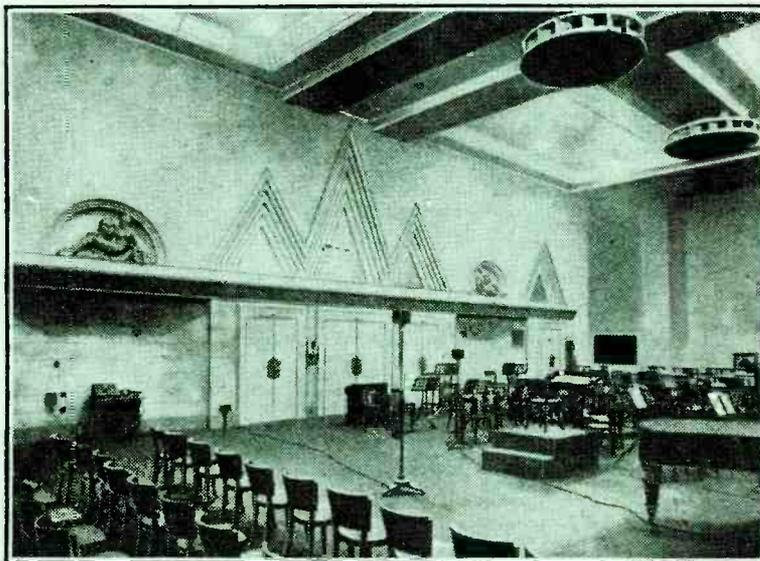

"RADIO ROMA." To-night at 7.30 o'clock Wagner's "Tristan and Isolde" is to be broadcast from this main studio in Broadcasting House, Rome.

Berne, 1,220 kc/s, 245.9 metres.—5.50 a.m. (from Zürich), Skiing Lesson. 6.5, Interval. 11.0 (from Berne), Gramophone Concert. 11.29, Time Signal from Neuchâtel Observatory. 11.40 (from Berne), Gramophone Concert. 12.25 p.m., Time, Weather and Exchange. 2.30 (from Berne), Talk for Women: Indoor Plants. 3.0 (from Berne), Concert by the Station Orchestra. 3.30, Programme of German Swiss Dialect Songs. 4.0, Famous Waltzes (on Gramophone Records). 4.30, Concert of Chamber Music. 5.0 (from Berne), Programme for Children. 5.30 (from Zürich), Talk. 6.0 (from Zürich), Time, Weather and Exchange. 6.20 (from Zürich), Elementary English Lesson. 6.50 (from Zürich), The Secret Marriage—Opera (Cimarosa). In the interval at 8.0 (approx.), Weather and News. 9.15 (approx.), Close Down.

**SOTTENS**.—See Radio-Suisse Romande.

**STOCKHOLM**

689 kc/s, 436 metres; 55 kW. Relayed by Boden, 242 kc/s, 1,239.5 metres; Göteborg, 932 kc/s, 322 metres; Hörby, 1,167 kc/s, 257 metres; Motala, 222.5 kc/s, 1,348 metres; Östersund, 402 kc/s, 746.2 metres; and Sundsvall, 554 kc/s, 542 metres.—12 Noon to 12.30 p.m., Broadcast for Schools. 4.5, Talk on Hunting, relayed from Uppsala, 662 kc/s, 453.1 metres. 4.25, Gramophone Music. 5.15, Reading relayed from the University, Uppsala. 6.0, Kreisler—Thibaud—Hubermann—Gramophone Music. 6.15, Weather and News. 6.30, Weather Report. 6.45, Piano-forte Recital by Mieczyslaw Münz: Melody (Gluck-Sgambati); Minuet (Haydn); Pieces (Chopin): (a) Nocturne in B, (b) Two Preludes, (c) Waltz in F; Prelude (Rach-

maninov); The Flight of the Bumble Bee (Rimsky-Korsakov); Impromptu Waltz (Liszt). 7.15, The Circle—Play (Somerset Maugham). 8.30, Recital of Swedish Folk Songs. 8.45, Weather and News. 9.0, Dance Music, relayed from Bernie Hall. 10.0 (approx.), Close Down.

**STRASBOURG**

869 kc/s, 345 metres; 11.5 kW.—11.30 a.m., Gramophone Music. 12.45 p.m., News. 1.0, Time. 1.1, Exchange. 1.5, Gramophone Concert. 4.45, Talk in German: Electricity. 5.0, Orchestral Concert, conducted by Roskani: One-Step, La chanson du canard (Raiter); Waltz, Weanermädl (Zielner); Overture, La fille de Madame Angot (Lecocq); Extracts from White Horse Inn (Stolz-Benatzky); Saxophone and Piano-forte: Serenade baline (Gabriel-Marie); Selection from La belle Héloïse (Offenbach); Two Melodies (Reisfeld and Marbot); Intermezzo, Patsy (Myddleton); Boston, I can't Remember (Berlin); March, Marching along together (Steininger). 6.0, Trio Music, relayed from Lille, 1,128.5 kc/s, 265.8 metres. 7.0, Assurance Societies' Reports. 7.15, Talk: The Skilled Trades. 7.30, Time and News. 7.45, Programme for Children, relayed from Paris (Eiffel Tower). 8.15, Press Review in German, and Lottery Results. 8.30, Concert by the Municipal Orchestra, conducted by Ansermet: Egmont Overture (Beethoven); Symphony No. 4 (Beethoven); Six Epigraphes antiques (Debussy-Ansermet); Symphonic Poem, La Mer (Debussy). In the interval at 9.30 (approx.), News. 10.30, Orchestral Con-

7.30, Overture, Fingal's Cave (Mendelssohn), by the Station Orchestra. 7.45, Chansonnettes. 8.0, Accordion Solos. 8.15, Music from Sound Films. 8.30, Opera Arias: Arias from Le chalet (Adam), The Bartered Bride (Smetana), Werther (Massenet), and Rigoletto (Verdi). 8.45, Orchestral Music: Adagio from Symphony No. 5 (Mahler); Quand l'amour meurt (Crémieux); March innébre d'une mariette (Gounod); At the Music-Hall—a Radio Fantasy. 9.0, Opera Music: Scene from Faust (Gounod); Forest Murmurs from Siegfried (Wagner); Selection from Rigoletto (Verdi). 9.45, Songs. 10.0, Operetta Music: Selection from Rose Marie (Friml); Air from Countess Maritza (Kálmán); Air from Yes (Yvain). 10.15, News. 10.30, Concert for Listeners in Morocco: Air de la folie, from Hamlet (Thomas); Dors O cité perverse, from Hérodiade (Massenet); Recitative and Lia's Aria from L'enfant prodige (Debussy). Part II: Light Orchestral Music. 11.0, Request Music. 11.15, Dance Music. 12 Midnight, News and Weather. 12.5 a.m. (Thursday), Light Music. 12.15, Music by a Viennese Orchestra: Waltz, España (Waldteufel); Strauss, Waltz Potpourri; Three O'clock in the Morning (Marchetti). 12.30 (approx.), Close Down.

**TRIESTE**

1,211 kc/s, 247.7 metres; 10 kW.—4.10 p.m. till Close Down, See Turin.

**TRONDHEIM**.—See Oslo.

**TURIN**

1,096 kc/s, 273.7 metres; 7 kW. Relayed by Milan, 903 kc/s, 332.2 metres; Genoa, 956 kc/s, 312.8 metres; and Florence, 598 kc/s, 501.6 metres.—4.10 p.m., Song Recital. 5.0 to 5.5, Weather. 5.40, Giornale Radio, Dopolavoro Report and Gramophone Music. 6.10, Wheat Market Report. 6.20, News in Foreign Languages. 6.40, Gramophone Music. 7.0, Giornale Radio and Weather. 7.15, Medical Talk. 7.30, Gramophone Music. 7.45, A Play in Three Acts, followed by Dance Music. 10.0, Giornale Radio.

**VATICAN CITY**

15,120 kc/s, 19.84 metres (Morning), and 5,969 kc/s, 50.26 metres (Evening); 10 kW.—10.0 to 10.15 a.m., Religious Information in Spanish. 7.0 to 7.15 p.m., Religious Information in Italian.

**VIENNA**

580 kc/s, 517.2 metres; 100 kW. Relayed by Graz, 852 kc/s, 352.1 metres; Innsbruck, 1,058 kc/s, 283 metres; Klagenfurt, 662 kc/s, 453.1 metres; Linz, 1,220 kc/s, 245.9 metres; and Salzburg, 1,373 kc/s, 218.5 metres.—10.30 a.m., Concert by the Vienna Chamber Orchestra, conducted by Oscar Jascha. In an interval at 10.55, Weather. 12 Noon, Time and News. 12.10 p.m., Gramophone Concert. 1.0, Interval. 2.0, Time and Announcements. 2.20, Report of the International Football Match, Austria v. Scotland, relayed from Glasgow. 4.20, Contemporary Austrian Composers (Max Springer). 5.10, Talk on Hygiene. 5.35, Talk: Acetylene, its Uses and Dangers. 6.0, Concert by the Wiener Symphoniker, conducted by Josef Holzner. In an interval at 6.35, Time and Announcements. 7.15, The Letter—Play in Three Acts (Somerset Maugham). 9.0, News. 9.10, Talk: What the Austrian Government has done for Business. 9.25, Dance Music, relayed from the Café Palmhof, followed by Announcements.

**WARSAW**

212.5 kc/s, 1,411 metres; 120 kW.—10.57 a.m., Time Signal and Fanfare from St. Mary's Church, Cracow. 11.5, Piano-forte Solos by Paderewski (on Gramophone Records). 11.30, Radio Journal. 11.35, Literary Programme from Cracow, 959 kc/s, 312.8 metres. 12.5 p.m., Weather. 12.8, Interval. 2.25, Announcements. 2.30, Economic Notes. 2.40, Gramophone Music. 3.5, Programme from Wilno, 530 kc/s, 566 metres. 3.40, Wireless Notes. 3.55, Light Music by the Cyparissia Theatre Orchestra; Soloist, Lawinski (Songs). 4.50, Agricultural Notes. 5.0, Talk. 5.20, Piano-forte Recital of Dances by Mme. Jonas: Gigue (Lully); Minuet (Muffat); Sarabande (Handel); Bourrée (Bach); Waltz No. 10 (Beethoven); Soirées viennoises (Schubert); Polonaise (Moniuszko); Waltz, Künstlerleben (Joh. Strauss); Fox-trot (Gershwini); Tango (Albeniz). 6.0, Programme Announcements. 6.5, Miscellaneous Items. 6.25, Poetry Reading, relayed from Wilno. 6.40, Sports Notes. 6.47, Radio Journal. 7.0, Concert of Polish Music by the Station Symphony Orchestra, conducted by Oximinski; Soloist, Mme Zmigrod-Fedyczkowska (Songs): Entr'acte and Finale from the Symphony in E Minor (Karłowicz); Berceuse for Strings (Naszyński); Symphonic Poem, Stanczyk (Rozycycki); Four Songs; Selection from Stara Basn (Zelenski); Mazurka (Allyniński); Symphonic Variations on a Chopin Prelude in A (Noskowski); Three Songs: (a) Langueur (Lefeld); (b) Sur l'eau (Paderewski); (c) Petite Annie (St. Lipski); Gipsy Dances from Manru (Paderewski); Popular Lithuanian Melody (Cieliecki); Melody (Nowowiejski). In the interval at 8.0, Talk. 9.15, Dance Music (on Gramophone Records). In the interval at 10.0, Weather and Police Notes.

**ZURICH**.—See Schweizerischer Landessender.

**STUTTGART**

**MUHLACKER**, 832 kc/s, 360.5 metres; 1.5 kW. Relayed by Freiburg, 527 kc/s, 570 metres.—12.25 p.m., Local News and Weather. 12.35, Concert of Operetta Music by the Station Orchestra, conducted by Otto Seyfert: Overture, Frühlingluft (Jos. Strauss); Selection from Eine Nacht in Venedig (Joh. Strauss); Waltzes from Der Walzerkrieg (Grothe-Melichar); Overture, Der Opernball (Heuberger); Selection from Paganini (Lelaur). 1.30, See Frankfurt. 2.30, Gramophone Records. 3.0 to 5.35, See Langenberg. 5.35, Talk: Educational Films in the New Germany. 5.50, Time, Agricultural Report and Weather. 6.0, Transmission for all German Stations, relayed from Frankfurt. 7.0, See Frankfurt. 7.10, A Radio Potpourri by the Station Orchestra and Soloists. 9.0, See Frankfurt. 9.20, What everyone should know. . . . 9.30, Local News, Weather and Sports Report. 9.45 to 11.0, See Frankfurt. 11.0, Serenade. 12 Midnight, Close Down.

**SUNDSVALL**.—See Stockholm.

**TOULOUSE**

779 kc/s, 385 metres; 8 kW.—6.0 p.m., News. 6.15, Music by an Argentine Band. 6.30, Light Music and Classical Music. 6.50, Talk, followed by Musical Items. 7.15, News,

## ALGIERS

825.5 kc/s, 363.3 metres; 13 kW.—7.0 p.m., Financial Notes. 7.10, Shipping Notes. 7.15, Agricultural Notes and Weather Report. 7.20, Concert. 7.55, News. 8.0, Time Signal. 8.2, Lottery Results. 8.10, Talk. 8.25, News. 8.30, Le quatrieme—Comedy in One Act (Martial Pechaud). 9.10, Concert of Request Gramophone Music. In the interval at 9.30, News. 9.55, News. 10.0, Concert of Oriental Music.

## ATHLONE

725 kc/s, 413 metres; 60 kW. Relayed by Dublin, 1,382 kc/s, 217 metres, and Cork, 1,337 kc/s, 224.4 metres.—1.30 to 2.30 p.m., Time Signal, Weather Report, Stock Report, and Gramophone Concert. 6.0, Programme for Children. 6.40, News. 7.0, French Lesson. 7.15, Talk. 7.30, Time Signal. 7.31, Dr. Annie Patterson in a Programme of her own Compositions. 8.0, Bass Solos by G. F. Walsh. 8.10, Piccolo Solos by Mollie Flynn. 8.25, The Station Orchestra. 8.40, Soprano Solos by Mue. A. Heffernan. 8.55, 'Cello Solos by Willie Reidy. 9.10, The Station Orchestra. 9.30 to 10.30, Programme by the I.B.C. (Ireland), Ltd. 9.30, Concert: Weymouth Chimes (Howlig); Xylophone Solo. Carnival of Venice (Briccialdi); Tales from the Vienna Woods (Joh. Strauss); Sticilietta (von Blon). 9.45, Concert: Musical Comedy Switch; The Song of Songs (Moya); One Morning very early (Sanderson); Selection from The Belle of New York (Kerker). 10.0, Concert arranged by the International Broadcasting Company (Ireland), Ltd.: Dance Music: Can't we meet again? Under a Blanket of Blue; Trouble in Paradise; Butterflies in the Rain; Carry me back to Green Pastures; I've found the Right Girl; Smoke Rings; Niagara Moon. 10.30, I.B.C. Goodnight Melody, followed by News and Weather. 10.40, Traditional Trio Music. 11.0 (approx.). Close Down.

## BARCELONA

EAJ1, 858 kc/s, 349.6 metres; 8 kW.—6.0 p.m., Trio Concert. In the interval: Talk. 7.0, Request Gramophone Music. In the interval at 7.30, Exchange. 8.0, Gramophone Music. 8.30, Educational Programme: Geography and History Lesson, followed by News. 9.0, Chimes from the Cathedral, Weather, Exchange and Market Prices. 9.5, Part Relay of an Opera, from the Gran Teatro del Liceo.

## BARI

1,112 kc/s, 269.8 metres; 20 kW.—3.30 p.m., Programme for Women. 3.50 to 7.0, See Rome. 7.0, News in Albanian. 7.15 till Close Down, See Rome.

BASLE.—See Schweizerischer Landessender.

## BELGRADE

698 kc/s, 429.7 metres; 2.8 kW.—6.0 p.m., Popular Music on Gramophone Records. 6.30, Talk. 7.0, Concert of Music by Contemporary Belgrade Composers. 8.0, Recitations. 8.20, Concert by the Station Orchestra. 9.0, Time and News. 9.15 (approx.), Dance Music from the Auto Club.

## BERLIN

DEUTSCHLANDSENDER (Reichssender), 183.5 kc/s, 1,635 metres; 60 kW.—11.0 a.m., Weather. 11.5, Gramophone Concert of Sound Film Music. After the Concert, Weather. 11.55, Time. 12 Noon, Interval. 12.45 p.m., News. 1.0, Dance Music on Gramophone Records. 1.45, Programme for Children. 2.15, Talk: In a Cement Works. 2.30, Weather and Exchange. 2.45, Talk: The History of Flying—The Flying Carpet of The Arabian Nights. 3.0, Concert from Heilsberg. 4.0, Advent Festival of the Union of Women Workers (on Gramophone Records). 4.20, Gramophone Records. 5.0, Poems. 5.5, Orchestral Concert. 5.30, Agricultural Talk. 5.50, Weather and Announcements. 6.0, Transmission for all German Stations, relayed from Berlin (Funkstunde). 7.0, Today's Motto. 7.5, Choral Concert in Aid of the Winter-Relief Fund, relayed from the Berlin Philharmonic. The Berlin Teachers' Choral Society, conducted by Hugo Rüdell. In the interval at 7.30 (approx.), Theatre Talk. 8.30, Hans von Bülow, a German Musician—a Dialogue between his Widow and Rudolf Schulz-Dornburg. 9.0, News and Sports Notes. 9.30, Report on German Boxing. 9.45, Weather. 10.0, See Leipzig. 11.0 (approx.), Close Down.

## BERLIN

FUNKSTUNDE, 716 kc/s, 419 metres; 1.5 kW.—Relayed by Zeesen, DJC, DJA, DUD, DJE, and DJE.—12 Noon, Gramophone Concert. Symphony, No. 2, in C, Op. 61 (Schumann); Waltz, Espana (Waldteufel); Tango, Du bist der Traum vom Glück (Borgmann-Buder); Polka, Marionetten (Landschutz); Waltz, Dort tanzt Lulu (Meisel); Tango, Von hunderttausend Frauen bist du die Eine (Lesso-Valerio); Ländler, Für Jung und Alt; Foxtrot, Hiawatha's Lullaby (Young-Donaldson); Waltz, Potpourri from Der Walzerkrieg (Melichar-Grotte); Foxtrot (Woods); Foxtrot (Raffelli); Paretzer Luisen-Polka (Niel); Waltz, Schwarzwaldmädelchen (Hildebrandt); Tango, Ein kleines bisschen Liebe (Carste); Waltz (German); Foxtrot, Oh Louise (Benatzky); Waltz, Dorfschwalben aus Oesterreich (Joh.

Strauss); Foxtrot, Atlantis (Robrecht). In the interval at 12.40 p.m. (approx.), News. 2.0, Exchange and Agricultural Prices. 2.20, A Radio Sequence for Girls. 2.50, The Nutcracker Suite (Tchaikovsky), on Gramophone Records. 3.15, Stage-Fright before an Operation—Report by a Surgeon. 3.30, See Munich. 4.45, Song Recital by Beniamino Gigli (on Gramophone Records). Arias from Ma noni (Massenet); The Pearl Fishers (Bizet); Tosea (Puccini); Manou Lescant (Puccini); and Cavalleria rusticana (Mascagni); Povero Pulcinella (Buzzi-Pecchia); Funiculi-Funicula (Dezza). 5.10, Reading (Rudolf Binding). 5.30, The Funkstunde informs its Listeners. . . . 5.35, Radio Report from Magdeburg. 5.45, Topical Talk. 6.0, Transmission for all German Stations. Beethoven Concert. The Station Orchestra, conducted by Otto Frickhoffer. Soloist: Rudolf Schmidt (Pianoforte); Pianoforte Concerto in B flat, Op. 19; Symphony in C, Op. 21. 7.5 to 11.0, Dance Music by Otto Kernbach's Band, the Station Quartet and Choir, conducted by Heinz Karl Weigel. In the interval at 9.0 (approx.), News and Sports Notes. 11.0 (approx.), Close Down.

BERNE.—See Schweizerischer Landessender.

BEROMUNSTER.—See Schweizerischer Landessender.

BODEN.—See Stockholm.

BODO.—See Oslo.

## BORDEAUX-LAFAYETTE

986 kc/s, 304 metres; 13 kW.—6.15 p.m., Radio Journal. 7.35, News and Racing Results. 7.40, Talk arranged by the International Labour Bureau. 7.55, Lottery Results. 8.0, Talk on Wine. 8.15, News. 8.30, Alibi—Comedy in Three Acts (Gabriel Trarieux).

## BRATISLAVA

1,073 kc/s, 279.5 metres; 14 kW.—3.0 p.m., Concert by the Station Orchestra, conducted by Dyk. Festival Overture (Bartovsky); Fantasia (Smetak); Extracts from Helene de Sparte (Brusselmann); Selection from Her Captain (Blecha); March (Moyzes). 3.50, See Brno. 4.15, See Prague. 4.25, Talk on Gymnastics. 4.35, See Prague. 4.50, Gramophone Records. 5.10, Talk on Peasant Life. 5.25, Concert of Light Music by the Station Orchestra, conducted by Karel Nagl. 5.55, Hints for Housewives. 6.0, See Prague. 6.30, See Brno. 7.30, See Prague. 10.0 (approx.), Close Down.

BREMEN.—See Hamburg.

## BRESLAU

923 kc/s, 325 metres; 60 kW.—Relayed by Gleiwitz, 1,185 kc/s, 253.1 metres.—11 a.m., Weather. 11.5, Concert by the Silesian Philharmonic Orchestra, conducted by Hermann Behr. Overture, L'Épreuve villageoise (Grétry); Two Movements from the Divertimento in D (Mozart); Three Military Marches (Schubert); Gavotte (Gossec); Die Hofballtänze (Lanner); Overture, The Daughter of the Regiment (Donizetti); Suite, Aus Holbergs Zeit (Grieg); Cavatine (Raff); Waltz, Wo die Zitronenblüh'n (Joh. Strauss). 12.45 p.m., Time, News, and Exchange. 1.10, Programme arranged by the Post Office with Gramophone Records. 1.40, Agricultural Prices. 2.0, Schubert Concert on Gramophone Records. Tenor Solo: Die Felle; The Trontquintet. 3.0, Programme for Children. 3.20, Orchestral Concert, relayed from the Café Vaterland. 4.35, Agricultural Prices. 4.40, Reading. 5.0, Talk on Hiking. 5.25, Programme to be announced. 5.45, Programme Announcements. 6.0, Transmission for all German Stations, relayed from Berlin (Funkstunde). 7.0, News. 7.10, Community Singing, relayed from the Südpark Restaurant. 8.10, St. Andrew's Evening in Silesia—a Radio Report from Waldenburg. 9.0, See Munich. 9.20, Time and News. 9.45, Sergeant on Gramophone Records. 11.0 (approx.), Close Down.

## BRNO

878 kc/s, 342 metres; 35 kW.—3.50 p.m., Programme for Children. 4.15, Talk for Young People. 4.25, See Prague. 4.50, Gramophone Music. 5.0, Theatre and Film Review. 5.15, See Prague. 5.25, German Transmission: News and a Sketch. 6.0, See Prague. 6.30, Variety Programme. 7.30, See Prague. 10.0 (approx.), Close Down.

## BRUSSELS (No. 1)

I.N.R., 589 kc/s, 509.2 metres; 15 kW.—12 Noon, Gramophone Concert of Light Music. 1.0 p.m., Le Journal Parlé. 1.10, Concert by the Small Station Orchestra, conducted by Leemans. Overture, Tancred (Rossini); Ballet Suite, La Source (Delibes); Invitation to the Dance (Weber).

(Guillemy); Selection from Bouche à bouche (Yvain). 5.0, Gramophone Concert of Music from Sound Films. 5.30, Programme for Children. 6.0, Talk: Women's Work. 6.15, Stenka Razin (Glazunov), on Gramophone Records. 6.30, Concert by the Small Station Orchestra, conducted by Leemans. Hindu March (Dupuis); Intermezzo (Benatti Malvezzi); Chant andaloux (Fort); Dance (Sneys); Selection from La jolie Suzette (Weyts); Ballet Music from Terpsichore (Ganne); 'Cello Solo: Remembrance (Desprez); Intermezzo, Korcha (Culotta); Russian Dance, 'Cabella. 7.15, Talk for Workers. 7.30, Sports Notes. 8.0, Concert by the Station Symphony Orchestra, conducted by Kumps. Overture, Die Fledermaus (Joh. Strauss); Suite orientale (Popy); Invitation to the Waltz (Weber); Selection from The Thieving Magpie (Rossini); Ballet Music from La cigale (Massenet). 8.45, Talk on the Economic Crisis. 9.0, Request Gramophone Concert. Rondo alla Turca (Mozart); Pathetic Sonata (Beethoven); Polonaise in E (Liszt); Cavatina (Raff); Duet from Act II and Quartet from Rigoletto (Verdi); Rhapsody, with a Song in my Heart (Rodgers-Coates); Selection from Evergreen (Hart and Rodgers). 10.0, Le Journal Parlé.

## BRUSSELS (No. 2)

N.I.R., 888 kc/s, 337.8 metres; 15 kW. Programme in Flemish.—12 Noon, Concert by the Small Station Orchestra, conducted by Leemans. Overture, Il Seraglio (Mozart); Campanella (Handel); Minuet from the Septet (Beethoven); Potpourri of Mendelssohn Music (Foulds); Gramophone Music: (a) Gloria (Gevaert); (b) Hallelujah from The Messiah (Handel); Selection from The Barber of Seville (Rossini); Waltz, Künstlerleben (Joh. Strauss). 1.0 p.m., Le Journal Parlé. 1.10, Selection from Iolanthe—Opera (Sullivan) on Gramophone Records. 5.0, Concert by the Symphony Orchestra, conducted by Kumps: K.V.R. Op. Strijdlid (Meulemans); March (Grieg); Les Préludes (Liszt); Mephisto-Walzer (Liszt). 5.30 to 7.15, Relay from the Sacred Heart Convent at Heverlé. 5.30, Programme for Children. 6.15, A Tale for Children. 6.30, Concert by the Elder Pupils. 7.12, K.V.R.O. Announcements. 7.15, Book and Film Review. 7.30, Talk for Women. 8.0, Third Act of Lourdes Play (Putman) with Introductory Talk by the Author. 8.45, Talk arranged by the Ligue du Sacré Coeur. 9.0, Concert by the Symphony Orchestra, conducted by Kumps: De Vlaamsche Leeuw (Miry); Danse des sorcières (de Boeck); Spanish Fantasia (Gevaert); Three Choral Songs (Vocht) on Gramophone Records: (a) Van Jezus en St. Janneke, (b) Slaap, kindoke, slaap, (c) Des winters als het regent; Overture, Maximilian Robespierre (Litoff); Waltz from The Sleeping Beauty (Tchaikovsky); Slav March (Tchaikovsky). 9.50, Evening Prayer. 10.0, Le Journal Parlé.

## BUCHAREST

761 kc/s, 394 metres; 12 kW.—4.0 p.m., Concert of Variety Music by the Grigoras Dinico Orchestra. In the interval at 5.5, Radio Journal. 6.0, Educational Talk. 6.20, Talk. 6.40, An Opera on Gramophone Records. In the intervals, Reading and Radio Journal.

## BUDAPEST

545 kc/s, 550.5 metres; 18.5 kW. Also relayed on 8.40 metres from 7.15 p.m. till Close Down.—4.30 p.m., Concert by the Lajos Kiss Cigany Band. 5.30, Talk, with Gramophone Records. 6.30, Recital of French, Spanish and Italian Songs by Therese Köszeghy. 7.15, Talk. 7.45, Violin Recital of Spanish Music by Juan Manen, followed by Sonata for Violin and Pianoforte (Cesar Franck), played by Juan Manen and Ernst Dolinanyi. 8.45, News. 9.10, Concert by the Budapest Concert Orchestra, conducted by Fiedl: Selection from The Merry Wives of Windsor (Nicolai); Hungarian Suite (Weiner); Selection from Adrienne Lecouvreur (Cilea); Ballet Suite, La Source (Delibes); Invitation to the Dance (Weber).

CASSEL.—See Frankfurt.

## COPENHAGEN

1,067 kc/s, 281 metres; 0.75 kW. Relayed by Kalundborg, 260 kc/s, 1,153.8 metres; and Skamleback, OXY.—11.0 a.m., Time and Chimes from the Town Hall. 11.5 to 1.0 p.m., String Ensemble Concert, relayed from the Ritz Restaurant. 1.45, Danish Dance Music by Sid Merrimann's Band. In the interval at 2.30 (approx.), Reading. 3.45, Programme for Boys. 4.30, Exchange and Fish Market Prices. 4.45, Talk: Greek Education. 5.15, Elementary English Lesson. 5.45, Weather and Announcements. 6.0, News. 6.15, Time Signal. 6.16, Talk: Democracy and Dictatorship. 6.45, Danish Lesson. 7.10,

Concert of Danish Music, relayed from the State Broadcasting Building. The Radio Symphony Orchestra, conducted by Lanny Grøndahl, the Radio Choir, and Soloists: Margherita Flor, Einar Norby, and Preben Rosing (Songs), and Herman Sandby ('Cello); Tornerose (Heise) for Soloists, Choir, and Orchestra; Ten Minutes' Interval; Movement from the Suite, Elverhøj (Glass); Two Movements from the 'Cello Concerto in D Minor (Sandby); Overture, Klods Hans (Riisager). 9.15, News. 9.30, From Heidelberg to Denmark—Variety Programme.

CORK.—See Athlone.

DANZIG.—See Heilsberg.

DRESDEN.—See Leipzig.

## FECAMP

1,328 kc/s, 225.9 metres; 10 kW.—10.30 to 11.30 a.m., Programme in English by the I.B.C. 10.30, Happy Hour; Part I, Orchestral Concert: Signature Tune; Waltz, Destiny (Baynes); Selection from Countess Mariza (Kálmán); Violin Solo: Souvenir (Drda); Selection from No, No, Nanette (Youmans); Fairy Tale (Heykens); Guitar Solo: Picking my Way (Lang-Kress); The Busy Bee (Bendix); The Way to the Heart (Lincke); Part II, Dance Music: I've got to get up and go to work; The Three Trees; Lazybones; Who's afraid of the Big Bad Wolf? Forever; Let the World go drifting by; Happy as the day is long; Blue Cloud; Signature Tune. 11.30, French Programme. 3.30 to 6.0, Programme in English by the I.B.C. 3.30, Orchestral Concert: Potpourri, Dubinushelika; The Clock is playing (Blaauw); Xylophone Solo: Fairy Tiptoe (Fredericks); Midnight Waltz (Spoliansky); Ginger Snaps (Bourdon); Xylophone Solo: Fiddlstick (Robbins); Moonlight at Sanssouci (Lotter); Amoureuse (Berger). 4.0, Dance Music: Signature Tune, The Bells of Normandy; Ah, but it's Love; The Three Trees; Avalon; I've found the Right Girl; Lover; The Wedding of Mr. Mickey Mouse; Adios, Goodbye; A One Horse Town; Signature Tune. 4.30, I.B.C. Nursery Corner: Birthday Greetings and Trumpets. 4.40, Worthing and Littlehampton Concert of Gramophone Records: Signature Tune, The Night, by the Sea; In a Clock Store (Orth); I stopped, I looked, I listened; The grass is getting greener all the Time (Burke); Pianoforte Solo: Please handle with care (Stride); Veterans of Variety; Richard of Taunton Deane (arr. Molloy); Whispering Flowers (von Blon); Violin Solo: The Pi-broch (Goulesco); Wine, Woman and Song (Strauss); Selection from The Quaker Girl (Monckton). 5.20, Brighton and Hove Concert of Light Music: Trumpets; The Mill in the Forest (Eilenberg); Kisses in the Dark (de Michel); Piccolo Solo: Fluttering Birds (Gemin); Selection from Wonder Bar (Katscher); Pianoforte Solo: My Heart stood still (Rodgers); The Golden Musical Box (Krome); Romance (Löhr); Signature Tune. 5.45, Dance Music: The Last Round Up; Pettin' in the Park; You're an Old Smoothie; Shadow Waltz. 6.0, French Programme. 10.0 till Close Down, Programme in English by the I.B.C. 10.0 (approx.), Sea Shanties; A Life on the Ocean (Binding); At Santa Barbara (Russell); Shenandoah (Terry); Selection from The Pirates of Penzance (Sullivan); The Drunken Sailor (Terry); One Dollar Fifty a Day; Praedidium (Järnefeld); Blow the Man Down; The Merchant Ship. 10.30, Dance Music: Signature Tune, The Bells of Normandy; Whistling under the Moon; Throw open wide your Window; Who's afraid of the Big Bad Wolf?; Night and Day; I'm getting sentimental over you; My Lucky Day; I can't remember; My Own. 11.0, Talkie Time; Signature Tune, Sittin' in the Dark; Selection from Love me To-night; Let me give my Happiness to you (Posford); Song, Pretty One (Strauss); Talking to you about me (Snyder); Johnny, from Song of Songs (Hollander); A nous la Liberté (Aurie); The Shadow Waltz (Dubin); You are my Heart's Delight (Lehar); Signature Tune. 11.30, Concert arranged by the International Broadcasting Company (Ireland), Ltd.: Signature Tune, Come back to Erin; Pas des Fleurs (Delibes); Violin Solo: Boublitohka; Norwegian Dance No. 2 (Grieg); The Londonderry Air (arr. Grainger); Minuet (Mozart); Valse des Fleurs (Tchaikovsky); Harlequin's Serenade, from I Pagliacci (Leoncavallo); Selection from A Thousand and One Nights (Strauss); Signature Tune, Come back to Erin. 12.5 a.m. (Friday), I.B.C. Late News Bulletin. 12.10 (approx.), Club Concert for Valley of the Usk Listeners: Signature Tune, The Chum Song; The Last Round Up (Hill); What a Perfect Combination (Kalmar); Hold your Man (Freed); A Couple of Pals (Gilbert); Symphony of the Breeze (Leon); Melody (Piccini); Dear Stranger (Hansen); Well done, Gordon (Gilbert); Come out Vienna (Herbert); My Mother's Garden (Hanley); Learn to Croon (Coslow); Tick, Tock (Vienna); I've got me on my mind (Porter); Signature Tune. 1.0, Organ Recital: Ding, Dong, Ding (Hargreaves); Serenade (Drigo); My Moonlight Madonna (Flich); Spirit of America (Zanecnik); There's something about a Soldier (Gay); In a Chinese Temple Garden (Ketybey); Isn't it Heavenly? (Hamburg); The Love Waltz (Heymann); 1.30, Light Music: Beautiful (Shay); Letting in the Sunshine (Gay); All over Italy (Munroe); That's my Home

NOV. 30th **THURSDAY** continued

(Rene): Pianoforte Selection from The Desert Song (Romberg); Any time, any day, anywhere (Washington); Polly (Zamecnik); Rosa mia (Guizar). 2.0, I.B.C. Goodnight Melody and Close Down.

**FLENSBURG.**—See Hamburg.  
**FLORENCE.**—See Turin.

**FRANKFURT**

1,157 kc/s, 259.3 metres; 17 kW. Relayed by Gassel and Trier, 1,157 kc/s, 259.3 metres.—12.15 p.m., Time and News. 12.25, Local News and Weather. 12.35, See Stuttgart. 1.40, Programme for Children. 2.30, Weather Forecast. 2.40, Time and Market Prices. 3.0, Concert by the Station Orchestra, conducted by Hans Rosshard. Soloist: Julius Dahlke (Pianoforte). Part I: Opera Music by Spohr. Overture and Cavatine from Faust; Extracts from Jessonda. Part II: Music for Pianoforte. Suite (Lully); March and Ländler (Mozart); Variations on a Theme of Gluck (Hummel); Melody (Heller); Abendfantasie (Loewe). Part III: Operetta Music by Zieheer; Overture, Ein tolles Mädel; Extracts from Der Schützmeister; Töne Liedchen, Töne durch die Nacht from Der Fremdenführer; Polka, Elektrisch; Extracts from Die Landstreichler; Duet from Das dumme Herz; March, Komödianten. 5.0, to 5.35, See Stuttgart. 5.35, Reading. 5.50, Weather, News and Time. 6.0, Transmission for all German Stations, relayed from Berlin (Funkstunde). 7.0, Topical Programme. 7.10 to 9.0, See Stuttgart. 9.0, Time and News. 9.20, See Stuttgart. 9.30, Local News and Weather. 9.45 to 12 Midnight, See Stuttgart. 12 Midnight, Interval. 12.55 a.m. (Friday) (also on Zeesen 31.38 metres), Concert of German Opera Music by the Station Orchestra. Soloist: Adolf Pernann (Baritone). 1.45 (approx.), Close Down.

**FREDRIKSSTAD.**—See Oslo.

**FREIBURG.**—See Stuttgart.

**GENEVA.**—See Radio-Suisse Romande.

**GENOA.**—See Turin.

**GLEIWITZ.**—See Breslau.

**GÖTEBORG.**—See Stockholm.

**GRAZ.**—See Vienna.

**HAMAR.**—See Oslo.

**HAMBURG**

806 kc/s, 372 metres; 1.5 kW. Relayed by Bremen, 1,112 kc/s, 269.8 metres; Flensburg and Hanover, 1,319 kc/s, 227.4 metres, and Kiel, 1,292 kc/s, 232.2 metres.—6.0 p.m., Transmission for all German Stations, relayed from Berlin (Funkstunde). 7.0, Mozart Concert; The Hamburg Philharmonic Orchestra, conducted by José Eibenschütz; Soloist, Otto Stadelmaier (Sings); Overture, Così fan tutte; Aria from The Magic Flute; Ballet Suite, Die Liebesprobe; Aria from Il Seraglio; Symphony in D, No. 88. 8.10, News. 8.20, Dance Music by the Small Station Orchestra, conducted by Gerhard Maasz. In the interval at 9.0, Time and News. 9.30, See Berlin (Deutschlandsender). 9.45, Dance Music (contd.). 11.0 (approx.), Close Down.

**HANOVER.**—See Hamburg.

**HEILSBURG**

1,085 kc/s, 276.5 metres; 60 kW. Relayed by Danzig, 671 kc/s, 447.1 metres.—12.5 p.m., Gramophone Concert; Ballet Suite (Gluck); Am Meer (Schubert); Wanderlied (Schumann); Eine kleine Nachtmusik (Mozart); Air (Bach); Ave Maria (Schubert); Ständchen (Schubert); On Wings of Song (Mendelssohn); Hungarian Dance (Brahms); Romances, Nos. 1 and 2 (Schumann); Overture, The Magic Flute (Mozart). In the intervals at 12.20 and 1.0, News. 1.30, Interval. 2.0, Agricultural Prices and Exchange. 2.30, Talk by Dr. Goebels: The Hitler-Jugend, Germany's Future Leaders. 3.0, Concert by the Station Orchestra, conducted by Eugen Wilcken: Turkish Suite (Gauwin); American Forest Idylls (MacDowell); Science Idyll (Scassola); Suite, Reminiscences of Cairo (Armandola); Overture, Der Bajazzo (Czibulka); Bei den Wiener Schrammeln (Recktenwald); Scenes poetiques (Godard); Waltz, Estudiantina (Waldteufel). In the interval at 4.0 (approx.), Book Review. 4.55, Elementary English Lesson. 5.15, Agricultural Prices. 5.25, Agricultural Talk. 5.50, Weather. 6.0, Transmission for all German Stations, relayed from Berlin (Funkstunde). 7.0, News and Weather. 7.10, Bunter Abend. 8.35 (from Danzig), Reading from Granite (Adalbert Stifter). 9.0, News and Sports Report. 9.30, Talk, on Gramophone Records: What People are Saying in America.

**HILVERSUM**

1,013 kc/s, 296.1 metres; 7 kW. up to 5.40 p.m. and 20 kW. from 5.40 p.m.—11.41 a.m., Concert of Light Music with Gramophone Interlude. 1.55, Interval. 2.10, Quartet No. 17 in C (Mozart). 2.40, Dressmaking Lesson. 3.25, Gramophone Music. 3.40, Programme for Hospitals. 4.10, Concert by the Wireless Orchestra, conducted by Nico Treep. Overture, Rosamunde (Schubert); Mendelssohn Potpourri (Urbach); Marche des petits

pierrrots (Bosc); Waltz, Myosotis (Waldteufel); Narzissenmädel (Siede); Mephistos Spiel (Dreyer); Serenata amorosa (Becece); Berceuse de Jocelyn (Godard); Selection from Noel Coward's Cavalcade; The Wedding of the Rose (Jessel); Une soir de fête à la Havane (Filippucci); Motor March (Rosey); March, Im Zigeunerlager (Oscheit); Waltz, Man schwebt dahin (Lincke); Hymn to Saint Cecilia (Gounod); The Cat and the Mouse (Engleman); In the Mystic Land of Egypt (Ketelbey). In the interval at 4.40, Radio Play for Children, and at 6.10, Sports Notes. 7.10, English Lesson. 7.40, Time and News. 7.45, Gramophone Music. 7.55, Concert by the Concertgebouw Orchestra, conducted by Ediard von Beinem, relayed from the Concertgebouw, Amsterdam. Soloist: Vera Janacopulos (Soprano), Overture (Boccherini); Three Arias (Rameau-Lully); Two Faust Choruses (den Hertog), conducted by the Composer. Soprano and Orchestra: Pribaoutki (Stravinsky); Pastorale d'été (Honegger); Psalm (Markovitch). 10.10, Gramophone Music. 10.40, News. 10.50, Gramophone Music. 11.40 (approx.), Close Down.

**HORBY.**—See Stockholm.

**HUIZEN**

160 kc/s, 1,875 metres; 7 kW. until 3.40 p.m. Transmitted from Kootwijk on 50 kW. from 3.40 p.m.—10.40 a.m. till 1.40 p.m., Programme of the Catholic Radio Society K.R.O.). 10.40, Gramophone Music. 11.10, Religious Address. 11.40, Police Notes. 11.55, Concert by the K.R.O. Orchestra, conducted by van 't Woud. Wiener Künstler (Schrammel); Overture, Prince Carnival (Blasius); Jung Heidelberg (Müllöcker); Blumengelächster (Blon); Sphinx (Popy); Overture, Czar and Carpenter (Lortzing); Gramophone Music; Toesin (Frietag); Spanish Legend (Rust); A Wedding Journey through Scandinavia (Frederiksen); Serenade (Widor); Selection from Le petit duc (Lecocq). 1.40 p.m. till Close Down, Programme of the Christian Radio Society (N.C.R.V.). 1.40, Handwork Lesson. 2.40, Programme for Women. 3.40, Bible Reading, followed by Baritone and Organ Recital by J. Smit Duyzentkunst and Smit Duyzentkunst. 4.40, Handwork Programme for Young People. 6.10, Contralto Song Recital by Martaja Fallak. 5.10, Talk. 6.25, Gramophone Music. 6.40, Police Notes. 6.55, Ecclesiastical Notes. 7.10, Review of the Week. 7.40, William of Orange Programme in Memory of his Landing at Scheveningen. The N.C.R.V. Choir and Orchestra. 8.40, Concert by the Small N.C.R.V. Orchestra and the N.V.R.V. Philharmonic Orchestra, conducted by Hurk. In the interval at 8.55, Talk, and at 9.45, News. 10.40, Gramophone Concert. 11.40 (approx.), Close Down.

**INNSBRUCK.**—See Vienna.

**JUAN LES PINS**

NICE, 1,205 kc/s, 249 metres; 0.8 kW.—8.0 p.m., Amusement Guide, Exchange and News. 8.10, Fashion Review. 8.20, Concert. 9.0, News and Weather. 9.15, Literary and Musical Programme.

**KALUNDBORG.**—See Copenhagen.

**KIEL.**—See Hamburg.

**KLAGENFURT.**—See Vienna.

**KOSICE.**—See Prague.

**LANGENBERG**

635 kc/s, 473 metres; 60 kW.—12.25 p.m., News and Weather. 12.35, See Stuttgart. 2.0, Thirty-two Variations in C Minor for Pianoforte (Beethoven), played by Hans Haass. 2.10, Winter Relief—Radio Picture by Wilhelm Rinke. 2.30, Market Prices. 2.50, Political Announcements. 3.0, See Frankfurt. 5.0, See Stuttgart. 5.35, Talk. 5.50, Announcements. 6.0, Transmission for all German Stations, relayed from Berlin (Funkstunde). 7.0, See Frankfurt. 7.10 to 9.0, See Stuttgart. 9.0, See Frankfurt. 9.20, See Stuttgart. 9.30, News. 9.45 to 12 Midnight, See Stuttgart. 12 Midnight, Close Down.

**LAUSANNE.**—See Radio-Suisse Romande.

**LEIPZIG**

770 kc/s, 389.6 metres; 120 kW. Relayed by Dresden, 941 kc/s, 319 metres.—11.0 a.m., Concert by the Leipzig Symphony Orchestra, conducted by Hilmar Weber: Overture, The Daughter of the Regiment (Donizetti); Serenade No. 1 in C for Strings (Volkmann); Hershelia-Suite (d'Ambrosio); Rhapsody in B Minor (Lhartung); Hilmar-Walzer (Deinert); Selection from The Merry Wives of Windsor (Nicolaï). 12.15 p.m., News. 12.30, Gramophone Music. 1.15, News. 1.30, Programme arranged by the Post Office, with Gramophone Records. 2.0 to 2.15, Notes for Taxpayers. 2.35, Market Prices. 3.0, Concert by the Station Orchestra, conducted by Willy Steffen; Soloist, Emil Lüh (Violin); Concert Overture (Grieg); Norwegian Rhapsody No. 3 (Svendens); In Sunny Spain

(Elliot); Ein Albumblatt (Wagner); Overture, La Part du Diable (Auber); Five Minuets (Schubert); Turkish March (Mozart). 4.30, Talk: The Beginning of the World. 5.0, Choral Concert. 5.25, Talk: Leipzig, the City of Books. 5.40, Market Prices and To-day's News. 6.0, Transmission for all German Stations, relayed from Berlin (Funkstunde). 7.0, The Sports Reporter—Humorous Anecdotes. 7.40, Symphony No. 7 in E Flat (Bruckner), by the Municipal and Gewandhaus Orchestras, conducted by Karl Muck, relayed from the Gewandhaus. 8.50, Lyrics (Theodor Storm). 9.0, News and Sports Notes. 10.0, Concert of Folk Music by Bandonion and Mandoline Orchestras: March, Heil Europa (von Blon); Concert Overture No. 3 in C (Kollmaneck); Im grünen Wald, dort wo die Drossel singt (Oscheit); Mandolietta, Op. 57 (Köhler); Stelldichein (Böhme); Paraphrase on the Song, An der Weser (Pressel-Kollmaneck); Polka-Mazurka, Alpenzauber (Gottlöber); Deutsche Weisen (Köhler); Spielmanns Abschied (Höser); Volkslieder-Ranken, Op. 69 (Wormsbacher); March, Zum Städtle hinaus (Meissner); Karl Boss-Marsch (Schuppe).

**LINZ.**—See Vienna.

**LUXEMBOURG**

252 kc/s, 1,191 metres; 200 kW.—German Evening. 7.0, Symphony in F—the "Pastoral" (Beethoven). 7.50, Topical Talk. 8.0, Song Recital by Angela Pallás: Three Songs (Schumann): (a) Der Nussbaum, (b) Du bist wie eine Blume, (c) Frühlingsnacht; Three Songs (Brahms): (a) Auf dem Kirchhofe, (b) Der Gang zum Liebhchen, (c) Am Sonntagmorgen; Three Songs (Wolf): (a) Das verlassene Mägdlein, (b) In dem Schatten meiner Locken, (c) Auftrug. 8.30, Concert by the Station Orchestra, conducted by Henri Pénis: Overture, Euryanthe (Weber); Two German Dances (Unger); Melody (Spies); Selection from Die toten Augen (d'Alberty); Nuit solitaire (Clémus). 9.45, News in German. 9.55, Selection from The Maid from the Black Forest (Jessel); Potpourri, Vienna by Night (Konczak); Oscar Straus Potpourri (arr. Dostal). 10.20, Dance Music by the Station Jazz Orchestra.

**LYONS**

LA DOUA, 644 kc/s, 465.8 metres; 3 kW.—7.40 p.m., Radio Gazette for Lyons and the South East. 8.30, Concert; Mlle. Carver (Songs); Mlle. Desgeorges (Harp); Raoul Barthalay (Violin) and Dujoles (Viola); Sonata in D Minor (Caporale); Melody (Searlatti); Harp Solo: Passacaglia (Handel); Préludes romantiques (Tournier); Gretchen am Spinnrade (Schubert); Préludes à deux (Migat); Trio for Strings in G Minor (Beethoven); Une sainte en son aurole (Faure); Variations for Harp (Samuel-Rousseau); Chinese Song (Volloines); Melody (Coppola); Melody (Castellano); Tedesco-Heifetz); Tambourin (Leclair). After the Concert, News.

**MADRID**

ARANJUEZ, EAQ, 10,000 kc/s, 30 metres; 10 kW.—10.30 p.m., Programme relayed from Madrid, EAJ7.—12.0 Midnight till Close Down, I.B.C. Concert of Light Music: The Regiment of Peace (Reisfeld); The Siege of Monte Carlo (Heymann); After Love (Erwin); Smile darn yerm, Smile (Rich); Secrets (Discepolo); The Rosary (Nevin); Aloha oe! (Liliuokalani); Hawaiian Sweetheart of mine (Heagney). 12.30 a.m. (Friday), I.B.C. Goodnight Melody and Close Down.

**MADRID**

EAJ7, 707 kc/s, 424.3 metres; 2 kW.—7.0 p.m., Chimes, Exchange, Announcements and Programme for Children. 8.15, Radio Journal. 8.30 to 9.15, Interval. 9.15, English Lesson. 9.30, Chimes, Time and Radio Journal. 9.45 (approx.), El Tesoro Imaginario—Radio Play (Pérez Ferrero and Julio de la Serna) with Incidental Music by Felipe Briones. 11.45, Radio Journal. 12.0 Midnight, Chimes. 1.0 a.m. (Friday) till Close Down, I.B.C. Concert of Dance Music: With you here and me here; Louisiville Lady; Egypt; Morella Waltz; Blue Prelude; Say it with Music; My Kingdom for a Smile from you; Down in the Valley; Blaze Away; Parade of the Minutes; Step Lightly; I lay me down to Sleep; Then the Moon came out; In Santa Lucia; A Waltz, a Night, a Tune; Spanish Sweetheart; Si petite. 2.0, I.B.C. Goodnight Melody and Close Down.

**MALMO.**—See Stockholm.

**MILAN.**—See Turin.

**MORAVSKA-OSTRAVA**

1,137 kc/s, 263.8 metres; 11 kW.—5.30 p.m., German Transmission: Talk. 6.0, See Prague. 6.30, Concert by the Station Orchestra, conducted by Musil: Selection from

The Geisha (Jones); Canzonetta (Friml); Spanish Intermezzo, Andalusia (de Taeye); Suite (Tapp); Czech Humoresque (Roub); Two Pieces (Bonček). 7.30, See Prague. 10.0 (approx.), Close Down.

**MOSCOW**

KOMINTERN (RW1), 202.5 kc/s, 1,481 metres; 500 kW.—3.15 p.m., Talk. 3.30, Educational Programme. 4.30, Red Army Programme. 5.30, Programme for Workers on Collective Farms. 6.30, Technical Talk. 7.0, Literary Programme. 8.0, Review of the Week in German. 8.55, Chimes from the Red Square. 9.5, Review of the Week in French. 10.5, Literary Programme in Spanish.

**MOTALA.**—See Stockholm.

**MUHLACKER.**—See Stuttgart.

**MUNICH**

563 kc/s, 533 metres; 1.5 kW. Relayed by Augsburg and Kaiserlautern, 536 kc/s, 560 metres; and Nürnberg, 1,256 kc/s, 239 metres.—3.30 p.m., Concert by the Small Station Orchestra, conducted by Karl List: Overture, The Pearl Fishers (Bizet); Suite, In a Fairy Realm (Ketelbey); Andalusian Romance (Saraste); Selection from The Flying Dutchman (Wagner); Waltz, Moososen (Schubert); Hungarian Rhapsody No. 13 (Liszt); Was die Quelle singt (Schytte); Serenade (de Taeye). 4.45, Agricultural Talk. 5.5, Recital of German Folk Songs. 5.25, Time, Weather and Agricultural Report. 5.40, Talk on Gramophone Records: What People are saying in America. 6.0, Transmission for all German Stations, relayed from Berlin (Funkstunde). 7.0, Variety Programme. Part I, The Bavarian Schrammel Quartet and Soloists. Part II, Besserer Herr gesucht (Refined Gentleman Wanted)—A Tragic-Comedy (Borro-Schwerla). 8.0, Concert by the Station Orchestra, conducted by Hans Winter. Soloist: Otto Goebel (Bass): Concerto grosso (Handel-Mottl); Two Songs for Bass and Orchestra (Schiffmann); Italian Serenade (Wolf); Sinfonietta (Jung). 9.0, Austria. 9.20, Time, News and Sports Notes.

**NAPLES.**—See Rome.

**NOTODDEN.**—See Oslo.

**OSLO**

277 kc/s, 1,083 metres; 60 kW. Relayed by Fredriksstad, 815 kc/s, 368.1 metres; Hamar, 522 kc/s, 574.7 metres; Notodden, 671 kc/s, 447.1 metres; Porsgrund, 662 kc/s, 453.1 metres; Rjukan, 671 kc/s, 447.1 metres; and Jeløy, LÖL, 6,990 kc/s, 42.92 metres.—4.0 p.m., Orchestral Concert, relayed from the Theatre Café. 5.0, German Lesson. 5.30, Divine Service. 6.0, Announcements, Weather and News. 6.30, Variety Programme by Pitt and Pott. 7.0, Time Signal. 7.1, Agricultural Talk. 7.30, A Journey around Europe with the Microphone. In the interval at 8.40, Weather and News, and at 9.0, Topical Talk. 11.0 (approx.), Close Down.

**ÖSTERSUND.**—See Stockholm.

**PALERMO**

556 kc/s, 539.5 metres; 3 kW.—7.0 p.m., Dopolavoro Announcements, Agricultural Notes and Giornale Radio. 7.20, Gramophone Music. In the interval at 7.30, Time and Announcements. 7.45, Operetta Music: Extracts from Rossini (Bellini), and The Merry Widow (Lehár). 8.30 (approx.), Lo zio prete—One Act Comedy (Tonelli). 9.0 (approx.), La Gran Via—Musical Play in One Act (Valverde). 10.0, Giornale Radio.

**PARIS**

EIFFEL TOWER, Call FLE, 207.5 kc/s, 1,445.7 metres; 13 kW. Time Signals (on 2,650 metres) at 9.20 a.m. and 10.26 p.m. (Preliminary and g-dot Signals). 5.45 p.m., Le Journal Parlé. 7.15, Weather. 7.25, News. 7.30, Gramophone Concert. Weber Music: Overture and Arias from Der Freischütz; Perpetuum mobile; Invitation to the Waltz. 8.0, Political Review. 8.15, Gramophone Concert (contd.). Selection from Les Dragons de Villars (Maillart); Saitarelle (Vieuxtemps); Pas des fleurs (Delibes); Les pliers de Manon (Gillet); The Druids' Prayer (Dawson); In the Temple of the Bells (Yoshitomo); La buissonnière (Wallence); Le plus légère (Messier); Défilé des bataillons (Blémant); Allégresse (Allier). 9.0 (approx.), Close Down.

**PARIS**

POSTE PARISIEN, 914 kc/s, 328.2 metres; 60 kW.—7.0 p.m., Gramophone Music. 7.5, Variety Item. 7.10, Agricultural Talk. 7.15, Le Journal Parlé. 7.30, Programme for Children. 8.0, Talk. 8.5, Topical Talk. 8.20, Interval. 8.40, Concert. 9.10, Interval. 9.30, Concert. 10.30, News.

**PARIS**

RADIO-PARIS; Call CFR 174 kc/s, 1,725 metres; 75 kW.—6.45 a.m., Physical Culture. 7.30, Weather and Physical Culture (contd.). 7.45, Gramophone Music. 8.0, Press Review and Weather. 12 Noon, Protestant Address. 12.30 p.m., Literary and Musical Programme

## NOV. 30th THURSDAY continued

(on Gramophone Records). Part I. Readings from *Le Cid* (Corneille). Polyette (Corneille); Andromaque (Racine), Berenice (Racine), *L'Avare* (Molière), and *Tartuffe* (Molière). Part II. Folies musicales (Betove); Souvenirs de Bayreuth (Fauré-Messenger); Selection from *Carmen* (Bizet); *The Nutcracker* Suite (Tchaikovsky); *Le petit Rentier* (Pierne); *La cage de cristal* (Ibert); Suite No. 2 (Stravinsky). In the interval at 1.0, Exchange, News, and Weather, and at 1.30, Exchange, 2.0, Exchange, 3.45, Exchange and Market Prices, 6.20, Agricultural Talk, 6.45, Legal Talk, 7.0, Talk on Maurice Rollinat, 7.20, Gramophone Music: Trink-Trunk (Bendix); Songs of the Hebrides (Kennedy-Fraser); Yvonne (Loyaux); La femme qu'on aime (Leardy-Gabrielle); Phomanie (Avignon), 7.45, Review of the German Press, 8.0, Two Plays. In the interval at 8.40, Review by Bonnaud, and at 9.15, Press Review and News.

## PITTSBURGH

KDKA, 980 kc/s, 306 metres; 50 kW. Relayed by W2XK on 48.86 metres and 25.27 metres.—6.45 p.m., Football Game (to be announced). 9.45, Thursday Special, from New York. 10.0, Federation of Pennsylvania Women. 10.15, KDKA Kiddies' Klub. 10.30, Singing Lady, from New York. 10.45, Orphan Annie, from New York. 11.0, News, Pat Haley. 11.15, Sports and Programme Preview. 11.30, Evenson. 11.45, Lowell Thomas, from New York. 12 Midnight, Amos 'n' Andy, from New York. 12.15 a.m. (Friday), Marvellous Melodies. 12.30, Lois Miller, Organist. 12.45 to 3.30, New York Relay. 12.45, Concert Footlights. 1.0, Captain Diamond. 1.30, Adventures in Health. 1.45, The Revellers. 2.0, Death Valley Days. 2.30, Lady Esther Serenade. 3.0, Hands across the Border.

PORSGRUND.—See Oslo.

## PRAGUE

614 kc/s, 488.6 metres; 120 kW.—3.0 p.m., See Bratislava. 3.50, See Brno. 4.15, Talk for Workers: The Czech-Slovak Glass Exhibition. 4.25, Gramophone Records. 4.35, Elementary French Lesson. 4.50, Gramophone Records. 5.5, Agricultural Talk. 5.15, Talk on Economics. 5.25, News in German. 5.30, German Transmission: Book Review and Agricultural Programme. 6.0, Time, News and Weather. 6.10, Talk. 6.15, Talk on Books. 6.30, See Brno. 7.30, Saint Helena—a Play in Four Acts (Heinz Steguwe). 9.0, Time, News, Review of the Day and Sports Notes. 9.15, Introductory Talk in Czech, German and French to the following Transmission. 9.25, String Quartet in E Minor, From *Out My Life* (Smetana), by the Czech Quartet. 10.0 (approx.), Close Down.

## RADIO-SUISSE ROMANDE

SOTTENS; 743 kc/s, 403 metres; 25 kW.; and Geneva, 400 kc/s, 749.9 metres.—6.0 to 6.15 a.m. (from Lausanne), Gymnastics. 11.28, Time Signal from Neuchâtel Observatory. 11.30, News and Weather. 11.40 (from Geneva), Variety Items. 12 Noon (from Geneva), Financial Notes. 12.10 p.m. (from Geneva), Gramophone Concert. 1.0, Interval. 2.58, Time Signal from Neuchâtel Observatory. 3.0 (from Geneva), Concert by the Radio-Suisse Romande Orchestra, conducted by Echenard. Soloist: Pépin (Flute). Overture, *The Secret Marriage* (Cimarosa); Ballet Music from *Rosamunde* (Schubert); Flute Solo: Minuet from *Orpheus and Eurydice* (Gluck); Sinfonia (J. C. Bach); *March militaire française* (Saint-Saëns); Kéler-Béla Potpourri; Serenade (Löhrr); Méloy (Rosen); Walt, *La housarde* (Ganne). 5.0 (from Lausanne), Baking Lesson. 5.30 (from Lausanne), Talk on the Scout Movement. 5.55 (from Lausanne), Tourist Report. 6.5 (from Lausanne), Talk: Aviation in 1788—the First Fire Balloon and the First Gas Balloon. 6.30 (from Lausanne), Agricultural Talk. 6.59, Weather Report. 7.0 (from Lausanne), 'Cello Recital by Gabriel Bise: Sonata in E Minor (Ariosti); *Canzonetta* (Bruck); *Minstrel Song* (Glazunov); *Oriental* (Cui); *Humoresque* (Julien). 7.30 (from Lausanne), *The Gipsy Princess*—Operetta in Three Acts (Kálmán), relayed from the Bel-Air Theatre. In the interval at 8.30 (approx.), News and Weather. 10.0 (approx.), Close Down.

## REYKJAVIK

250 kc/s, 1,200 metres; 21 kW.—8.0 p.m., Musical Programme. 8.10, Weather. 8.20, Musical Programme and Announcements. 8.35, Programme to be announced. 9.0, Chimes. 9.2, Concert by the Radio Trio. 9.30, Reading. 10.0, News. 10.30, Arias on Gramophone Records, followed by Dance Music. 11.30 (approx.), Close Down.

## RIGA

571 kc/s, 525.3 metres; 15 kW.—6.5, Paganini—Operetta in Three Acts (Lohár). In the intervals, News and Weather. 8.30, Classical Music on Gramophone Records, Minuet, Allegro and Finale Vivace from the Symphony in D (Haydn); Andante cantabile from the Quartet in G (Mozart); Adagio from the Pathetic Sonata (Beethoven); Air

(Bach); Aria from *The Messiah* (Händel); Allegro moderato and Andante from *Trio No. 1* (Schubert).

RJUKAN.—See Oslo.

## ROME

Call 1R0, 680 kc/s, 441 metres; 50 kW. Relayed by Naples, 941 kc/s, 319 metres; Milan (Vigentino), 662 kc/s, 453.1 metres from 7.45 p.m.; and 2R0, 11,810 kc/s, 25.4 metres.—12.10 to 1.15 p.m., Concert from Turin. In the intervals at 12.30, *Giornale Radio* and Exchange, and at 1.0, Time and Announcements. 3.30, Children's Radio Review. 3.50, *Giornale Radio* and Exchange. 4.0, Talk. 4.10, Weather Forecast. 4.15, Vocal and Instrumental Concert: *Prichetta Petacci* (Pianoforte), *Annibale Bucchi* (Violin), *Luigi Chiarappa* (Cello) and *Gianna Perea Labia* (Soprano); *Pianoforte Trio in B, Op. 8* (Brahms); *Soprano Solos*: (a) *Arietta* (Blangini), (b) *Nina pazzo per amore* (Paisiello), (c) *Song* (Proch); *Pianoforte Trio in B flat, Op. 99* (Schubert). 5.0, Talk: The College of Agriculture. 5.40 (Naples), Shipping and Sports Notes. 5.45, *Dopolavoro* Announcements and Tourist Report. 6.10, Agricultural Notes and Wheat Market Report. 6.20, News in Foreign Languages. 6.40, *Giornale Radio*. 7.0, Time and Announcements. 7.15, Soprano Solos by Elisa Capolino. 7.30, *Giornale Radio* and Sports Notes. 7.45, *Symphony Concert* conducted by Rito Selvaigi. In the intervals, Literary and Art Notes and Announcements. 10.0, *Giornale Radio*.

SALZBURG.—See Vienna.

## SCHENECTADY

WGY, 790 kc/s, 379.5 metres; 50 kW. Relayed at intervals by W2XAF on 31.48 metres, and by W2XAD on 19.56 metres.—12.45 to 4.0 a.m. (Friday), New York Relay. 12.45, Trials of the Goldbergs. 1.0, Popular Programme. 2.0, Capt. Henry's Show Boat. 3.0, Popular Programme. 4.0, Programme Résumé.

SCHWEIZERISCHER  
LANDESSENDER

BEROMUNSTER, 653 kc/s, 459 metres; 60 kW.; Basle, 1,229 kc/s, 244.1 metres; and Berne, 1,220 kc/s, 245.9 metres.—5.50 a.m. to 6.5 (from Berne), Gymnastics. 9.20 (from Berne), Broadcast for Schools. 9.50, Interval. 11.0 (from Zürich), Hints for Housewives. 11.5 (from Zürich), Concert by the Small Station Orchestra, conducted by Scherbaum. 12.25 p.m. (from Zürich), Time, Weather and Exchange. 2.30 (from Zürich), Light Music by the Station Orchestra. 3.0, See Radio-Suisse Romande. 5.0 (from Basle), Light Music on Gramophone Records. 5.30 (from Basle), Legal Talk: The Employment Contract. 6.0 (from Basle), Time, Weather and Tourist Report. 6.5 (from Basle), Review of New Gramophone Records. 7.0 (from Basle), Talk: Inventions and Inventions. 7.30 (from Basle), Violin Recital. 8.0, Weather and News. 8.10 (from Basle), Concert by the Railway Male Voice Choir and Hans Vogt (Pianoforte). 9.15 (approx.), Close Down.

SOTTENS.—See Radio-Suisse Romande.

## STOCKHOLM

689 kc/s, 436 metres; 55 kW. Relayed by Boden, 242 kc/s, 1,239.5 metres; Göteborg, 932 kc/s, 322 metres; Hörby, 1,167 kc/s, 257 metres; Motala, 222.5 kc/s, 1,348 metres; Östersund, 402 kc/s, 746.2 metres; and Sundsvall, 554 kc/s, 542 metres.—4.5 p.m. (from Göteborg), Divine Service. 4.30, Programme for Children. 4.45, Gramophone Music. 5.45, Elementary English Lesson, relayed from Jönköping, 1,490 kc/s, 201.3 metres. 6.15, Weather and News. 6.30 (from Göteborg), Talk. 7.0, Arthur Hazelius Memorial Programme. Choral and Orchestral Concert, conducted by Sven Kjellström and Soloists: Helga Görin (Soprano) and Joel Berglund (Bass); *Offertorium* (Söderman); *Cantata* (Rangström). In the interval: Address by Andreas Lindblom. 8.20, Radio Report. 8.45, Weather and News. 9.0, Concert by Eva Pawlo (Songs), Lottie Andreasson (Violin), Helge Lindeberg (Pianoforte) and Fritjof Kjellberg (Pianoforte). Selection from *A Midnight Tango* (Komzak); Violin Solos: (a) *Serenade* (Townsend), (b) *Poème* (Fibich), (c) *Tango* (Albéniz); *Pianoforte Duets*: (a) *Waltz* (Greer), (b) *Foxtrot*, Russian Cocktail (Kaper); Violin Solos: (a) *Lullaby* (Juon), (b) *Gipsy Dance* (Nachez); *Three Pieces* (Lindberg). 10.0 (approx.), Close Down.

## STRASBOURG

869 kc/s, 345 metres; 11.5 kW.—11.30 a.m., Gramophone Concert. 12.45 p.m., News. 1.0, Time and Exchange. 1.15, Light Music on Gramophone Records. 2.0, Programme for Children. 3.0, Orchestral Concert, conducted by Roskam: Overture, *Sous la Régence* (Brusselmans); *Waltz* from *Der Rosen-*

kavalier (R. Strauss); *Promenade sous bois* (Lacombe); Selection from *Les Saltimbanques* (Ganne); Selection from *Hans the Flute Player* (Ganne); *Sous la Feuillée*—Aubade for Flute, Clarinet, and String Orchestra (Sandré); *Hymn to the Sun and Indian Dance* (Rimsky-Korsakov); *Radio March* (Peking). In the interval from 3.30 to 3.45, *Elocution Lesson*. 4.15, Programme for Children, relayed from Bordeaux-Lafayette, 986 kc/s, 304 metres. 6.0, Talk in German on Austrian Literature: Hugo von Hofmannsthal. 6.15, Talk for Housewives. 6.30, Gramophone Records of Light Music. 7.30, Time and News. 7.45, Gramophone Music. 8.0, Press Review in German, Lottery Results, and Announcements. 8.30, Concert of Chamber Music by Mme. Biellmann (Soprano), Bour (Pianoforte), and the Station Soloists: French Suite in G (Bach); Andante for Horn (Gottmann); Songs: (a) *Butterfly* (Campra), (b) *Aria* from *Julius Caesar* (Handel); *Quintet for Flute, Oboe, Clarinet, Bassoon, and Horn* (Monfeillard); *Pianoforte Sonata* (Mozart); Songs: (a) *Aria* from *Le pastore* (Mozart), (b) *Prayer* from *Die Music to Goethe's Faust* (Schumann); *Scherzo* for Bassoon (Delannay); Oboe Solo: *Circassian Dance* (Moreau); Songs: (a) *Réponse d'une épouse sage* (Roussel), (b) *Le Bachelier de Salamancque* (Roussel), (c) *Le Tombeau* (Poulenc), (d) *Attributs* (Poulenc); *Five Pieces on the Name Bach*: (a) *Piece* (Roussel), (b) *Récit* (Cassella), (c) *Waltz-Improvisation* (Poulenc), (d) *Prelude to an imaginary Fugue* (Malipiero), (e) *Prelude, Arioso, and Fughetta* (Honegger). In the interval at 9.30, Press Review in French. 11.30 (approx.), Close Down.

## STUTTGART

MUHLACKER, 832 kc/s, 360.5 metres; 1.5 kW. Relayed by Freiburg, 527 kc/s, 570 metres.—12.25 p.m., Local News and Weather. 12.35 to 1.30, Concert by the Cast of the Scala, Milan, on Gramophone Records. 2.0, Programme for Children. 3.0, See Frankfurt. 5.0, Spanish Conversation. 5.20, Talk. 5.35, Talk on Photography. 5.50, Time, Agricultural Notes and Weather. 6.0, Transmission for all German Stations, relayed from Berlin (Funkstunde). 7.0, See Frankfurt. 7.10, Goethe-Mörke-Heynike—Recital of Lyrics, with Commentary, relayed from the Liederhalle. The Station String Quartet and Walter Reuschle (Recitations). 8.0, Concert by the Station Orchestra, conducted by Gustav Görlich. 9.0, See Frankfurt. 9.20, What everyone should know. 9.30, Local News, Weather and Sports Report. 9.45, Gramophone Music. 10.0, Concert (continued). 11.0, Serenade. 12 Midnight, Close Down.

SUNDSVALL.—See Stockholm.

## TOULOUSE

779 kc/s, 385 metres; 8 kW.—6.0 p.m., News. 6.15, Music by a Viennese Orchestra. Du und Du (Strauss); Tales from the Vienna Woods (Strauss); *Lieder der Liebesnacht* (Lincke); *Was Blüher träumen* (Translatour). 6.30, Programme for Children. 7.0, Tango Songs. 7.15, News. 7.30, Pianoforte Recital. *Fantaisie inpromptu* (Chopin); *Séguidilla* (Albéniz); *La soirée dans Grenade* (Debussy); *Gavotte variée* (Rameau). 7.45, Military Music. 8.0, Opera Arias. Arias from *Mirella* (Gounod), *Les dragons de Villars* (Maillart), *Lakmé* (Delibes) and *Werther* (Massenet). 8.15, Operetta Music. Selection from *The Chocolate Soldier* (O. Straus); *Waltz* from *The Girl in the Taxi* (Gilbert); Selection from *A Waltz Dream* (O. Straus). 8.30, Music from Sound Films. 8.45, Music by the Symphony Orchestra. Ballet Music from *Rosamunde* (Schubert); Norwegian Dance No. 2 (Grieg); *Symphonic andante* (Bach); Hungarian Dance No. 2 (Brahms). 9.0, Moretti Concert. Songs from Delphine. Ah, quelle Gare, Si tu veuilles, *Sous les toits de Paris*, Un soir de veuillon, *Conte Obligado*, *Le roi des palaces* and *Il est charmant*. 9.30, Orchestral Music. 9.45, Opera Music. *Varlaam's Aria* from *Boris Godunov* (Moussorgsky); *Aria* from *The Mastersingers* (Wagner); *Aria* from *Sigurd* (Reyer). 10.0, Accordion Solos. 10.15, North African News. 10.30, Concert of Songs and Military Music for Listeners in Morocco. 11.0, Light Music by a Viennese Orchestra. 11.15, Dance Music. 12 Midnight, News, Weather and Announcements. 12.5 a.m. (Friday), Chasonettes. 12.15, Dance Music: Two Steps. 12.30 (approx.), Close Down.

## TRIESTE

1,211 kc/s, 247.7 metres; 10 kW.—4.10 p.m., till Close Down, See Turin.

TRONDHEIM.—See Oslo.

## TURIN

1,096 kc/s, 273.7 metres; 7 kW. Relayed by Milan, 903 kc/s, 332.2 metres; Genoa, 959 kc/s, 312.8 metres; and Florence, 598 kc/s, 501.6 metres.—4.10 p.m., Chamber Music on

Gramophone Records: *Ridda di folletti* (Bazzini); *Scherzo* and *Tarantella* (Wieniawsky); *Sarabande* and *Allegretto* (Corelli-Kreiser); *Minuet* from the *Quartet No. 19* (Mozart); *Minuet* (Becker); *Cantilena* (Goltermann); *Canzonetta* (de Laserna); *Liebstraum* (Liszt-Schipa); *Fanciulla* (Ciampi); *Humoresque* from the *Quartet in A Minor* (Ippolitov-Ivanov). 5.0 to 5.5, Weather. 5.40, *Giornale Radio*, *Dopolavoro* Report and Gramophone Music. 6.0, Time, Tourist Report and Gramophone Music. 6.10, Wheat Market Report. 6.20, News in Foreign Languages. 6.40, Gramophone Music. 7.0, *Giornale Radio*, Weather and Gramophone Music. 7.25, Talk on the following transmission. 7.30, *La giornata di Marcellina*—Opera in Three Acts (Attilio Parelli), conducted by the Composer. Talk and Literary Notes in the interval. *Giornale Radio* after the Opera.

## VATICAN CITY

15,120 kc/s, 19.84 metres (Morning) and 5,969 kc/s, 50.26 metres (Evening); 10 kW.—10.0 to 10.15 a.m., Religious Information in French. 7.0 to 7.15 p.m., Religious Information in Italian.

## VIENNA

580 kc/s, 517.2 metres; 100 kW. Relayed by Graz, 852 kc/s, 352.1 metres; Innsbruck, 1,058 kc/s, 283 metres; Klagenfurt, 662 kc/s, 453.1 metres; Linz, 1,220 kc/s, 245.9 metres; and Salzburg, 1,373 kc/s, 218.5 metres.—11.0 a.m., Concert by the Wiener Symphoniker, conducted by Josef Holzer: Overture, *The Barber of Seville* (Rossini); Selection from *Tieffand* (d'Albert); Flute Solo: *Minuet* (Mozart); *Waltz*, *Phantasiestücke* (Jos. Strauss); *Kinderliedersuite* (Blechl); *Potpourri*, *Strauss-Federn* (Morena); *March*, St. Luis (Komzak); *Waltz* (Waldteufel); *Fantastic Suite*, *Kalif Storch* (Wenzl); *Song*, *Wiener-Wald-Zauber* (Precht); *Die bösen Buben* (Manfred); *Ländler*, *Gebirgsmelodien* (Preis); Selection from *Don Cesar* (Dellinger); Overture, *Der Göttergatte* (Lohár). In an interval at 12 Noon, Time and News. 1.0 p.m., Interval. 2.0, Time and Announcements. 2.15, Talk: The Austrian Shoe Industry. 2.25, Programme for Children. 2.50, Gramophone Concert of Operetta Overtures: *Im Reich des Indra* (Lincke); *Flotte Bürsche* (Suppé); *The Gipsy Baron* (Joh. Strauss); *Baudienstreiche* (Suppé); *La belle Héleine* (Offenbach). 3.30, Talk on Gardening. 3.50, Talk for Women: *The Convents of Austria*. 4.15, Soprano and Pianoforte Recital by Anny Kimmelman and Anny Nikel. Two Songs (Schumann): (a) *Erstes Grün*, (b) *Aus den östlichen Rosen*; *Three Songs* (Brahms): (a) *Nicht mehr zu dir zu gehen*, (b) *Folk Song*, *Mein Mädel hat einen Rosenmund*, (c) *Salome*; *Pianoforte Sonata in G Minor*, Op. 88 (Fuchs). 4.55, Talk on Tin. 5.20, Talk: Conditions in Austria To-day. 5.45, Theatre Review. 5.55, *Aida*—Opera in Four Acts (Verdi), relayed from the State Opera House. In the interval at 6.45, Time and Announcements, and at 8.0, News. 9.15, Talk in Hungarian. 9.25, Light Music on Gramophone Records, followed by Announcements.

## WARSAW

212.5 kc/s, 1,411 metres; 120 kW.—10.57 a.m., Time Signal and Fantare from St. Mary's Church, Cracow. 11.5, Polish Songs on Gramophone Records. 11.30, Radio Journal. 11.35, Concert by the Philharmonic Orchestra, with Commentary. Conductor: Oziminski. Soloist: Karkowska (Songs). Overture, *Figaro* (Mozart); *Air* (Bach); *Minuet* and *Finale* from *Symphony No. 7* (Beydn); *Turkish March*, from *The Ruins of Athens* (Beethoven); *Classic Songs*; Overture (Nowojewski); Polish Songs; *Gipsy Dance* (Moszkowsky); *Mazurka* from *Januta* (Moniuszko). 1.0 p.m., Interval. 1.3, Interval. 2.25, News. 2.30, Economic Notes. 2.40, Orchestral Concert, relayed from Lwów, 788 kc/s, 381 metres. 3.40, Programme for Women. 3.55, *Aria* and Song Recital by Wyszatycki. 4.10, Pianoforte Recital by Jasinski: *Prelude* and *Triple Fugue in E Flat* (Bach—Busoni); *Minnet in A Minor* (Rameau-Godowsky); Two Extracts from *Le tombeau de Couperin* (Ravel); *Sonata No. 5*, Op. 53 (Scriabin). 4.50, Rural Programme for Young People. 5.0, Talk: Books and the Reader. 5.20, Dramatic Programme. 6.0, Programme Announcements. 6.5, Miscellaneous Items. 6.25, Topical Talk. 6.40, Sports Notes. 6.47, Radio Journal. 6.55, Interval. 7.0, Concert by the Symphony Orchestra, conducted by Oziminski. Soloist: Pia Ravenna (Songs). Suite *Asacienne* (Massenet); *Barcarolle* (Dutowsky); *Minuet* (Bolzoni); *Petite marche viennoise* (Kreiser); *Three Songs* (Sibelius); *Four Songs* (Järnefelt); *Tone Picture for Violin, Harp and Orchestra*, *Les Néréides* (Brusselmans); *Song* from *King Christian II* (Sibelius); *Berceuse* (Järnefelt); *Valse triste* (Sibelius); Songs: (a) *Lullaby* (Hainikainen), (b) *Mademoiselle Rococo* (Melartin), (c) *Two Songs* (Klemetti), (d) *Finnish Lullaby* (Merikanto); *La pendola armoniosa* (Piek-Mangiaglianti); *Rhapsody* on Popular Swedish Melodies (Lindberg). In an interval at 8.0, Answers to Correspondents. 9.0, Cigány Music. In an interval at 10.0, News.

ZÜRICH.—See Schweizerischer Landessender.

# FRIDAY

## DECEMBER THE FIRST

### ALGIERS

825.5 kc/s, 363.3 metres; 13 kW.—7.0 p.m., Financial Notes. 7.10, Shipping Notes. 7.15, Agricultural Notes and Weather Report. 7.20, Dance Music. 7.55, News. 8.0, Time Signal. 8.2, Lottery Results. 8.10, Saint-Saëns Concert by the Station Orchestra, conducted by Defosse: Symphonic Poem, La Jeunesse d'Hercule; Adagio from Symphony No. 3; Ballet Music from Javotte; Selection from La Princesse Jaune; Phaëton; Marche héroïque. In the interval at 8.35, News, and at 8.40, Talk. 9.55, News.

### ATHLONE

725 kc/s, 413 metres; 60 kW. Relayed by Dublin, 1,382 kc/s, 217 metres; and Cork, 1,337 kc/s, 224.4 metres.—1.30 to 2.30 p.m., Time Signal, Weather Report. Stock Report and Gramophone Concert. 6.0, Programme for Children. 6.45, News. 7.0, Gardening Talk. 7.15, Literary and Dramatic Talk. 7.30, Time Signal. 7.31, The Station Orchestra. 7.45, The Caledonian Male Voice Choir. 8.0, The Station Orchestra (cont'd.). 8.15, Choral Concert (cont'd.). 8.30, Mezzo-Soprano Solos by Mary Maguire. 8.45, Concert by the Station Orchestra. 9.15, Traditional Songs by Patrick Parle. 9.30 to 10.30, Programme by the I.B.C. (Ireland), Ltd. 9.30, Concert of Dance Music: Little Sunshine; The Grass is getting Greener; Madrid; Are you sure you love me?; Sophisticated Lady; Good-night Vienna; Looking Forward; Moonlight Madonna. 10.0, Concert arranged by the International Broadcasting Company (Ireland), Ltd.: The Merry Widow Waltz (Lehar); Selection from Chu Chin Chow (Norton); Song, An Old Violin (Fisher); Racing Commentary: Ständchen (Heykens); Trumpet Solo: Rockin' Chair (Carmichael); Song: Alice Blue Gown (Tierney); Over the Waves (Rosas). 10.30, I.B.C. Goodnight Melody, followed by News and Weather. 10.40, Fiddle and Accordion Recital by Harpur and Bates. 11.0 (approx.), Close Down.

### BARCELONA

EAJ1, 858 kc/s, 349.6 metres; 8 kW.—6.0 p.m., Trio Concert: Selection from The Rhinegold (Wagner); Melody (Tchaikovsky); Song of the Bees (Filippucci); Minuet, Op. 81 (Drlia); Selection from Mephistopheles (Boito); Intermezzo (Delmas); Polonaise in F (Schubert). 7.0, Request Gramophone Music. 7.30, Exchange and Gramophone Music (cont'd.). 8.0, Gramophone Music. 8.30, Educational Programme: Geography and History Lesson, followed by News. 9.0, Chimes from the Cathedral, Weather. Messages to Seamen, Exchange and Market Prices. 9.10, Concert by the Radio Orchestra. Soloist: Julio Jarque (Violin). 10.30, Dance Music relayed from the Casa Llibre. In the interval at 11.0, News. 12 Midnight (approx.), Close Down.

BASLE.—See Schweizerischer Landessender.

### BELGRADE

398 kc/s, 429.7 metres; 2.8 kW.—6.0 p.m., Talk. 6.30, A Musical Play. 8.0, Military Band Concert. In the interval at 9.0, Time and News. 9.45, Cigány Music from the Dva Jelena Restaurant.

### BERLIN

**DEUTSCHLANDSENDER** (Reichssender), 183.5 kc/s, 1,635 metres; 60 kW.—1.0 p.m., Light Music on Gramophone Records. 2.0, Programme for Girls. 2.30, Weather and Exchange. 2.45, Talk: The History of Flying—The Airship Cianozzo. 3.0, Concert, relayed from Stuttgart. 4.0, Talk: Can Culture be taught? 4.25, Folk Song Duets and Trios by the German Women's Trio; Old German Folk Songs for Trio: (a) Ich muss von ihnen scheiden, (b) Goldringel, (c) Ich armes Mädchen, (d) Wenn ich ein Voglein wär, (e) Es zog ein Täublein weisse, (f) Schlaf mein Kindelein; Duets: (a) Treue Liebe, (b) Die Sonne scheint nicht mehr, (c) Das Veilchen, (d) Zwei Königskinder, (e) Sandmännchen, (f) Abendsegen; Sacred Songs for Three Voices (Mozart): (a) Götter, welche schwere Prüfung, (b) Einsam und still will ich beklagen, (c) Glaubt mir. Beständigkeit ziert die Liebe. 5.0, Poems. 5.5, Legal Talk. 5.25, Wolfgang Herrmann reads from the Book, Sturm 33 (Hans Malzkowski). 5.45, Weather and News. 6.0, Transmission for all German Stations, relayed from Heilsberg. 7.0, To-day's Motto. 7.5, Talk: Preparations for Ski-ing. 7.20, Topical Talk. 7.30, Winke, bunter Wimpel—Radio Ballad (Alfred Karasch), with incidental Music by Walter Gronostay. 9.0, Weather and News. 9.45, Weather. 10.0, Gramophone Report of a Boxing Contest in the Sportpalast. 10.15, Concert, relayed from Frankfurt. 11.0 (approx.), Close Down.

### BERLIN

FUNKSTUNDE; 716 kc/s, 419 metres; 1.5 kW. Relayed by Zeesen, DJC, DJA, DJD, DJB, and DJE.—2.20 p.m., Gramophone Concert: Andante and Finale from the Flute Concerto in C (Mozart); Andante and Rondo from the Bassoon Concerto (Mozart); Larghetto from the Violin Concerto in D (Mozart); Finale from the Violin and Cello Concerto in A Minor (Brahms). 3.0, See

Heilsberg. 4.0, See Hamburg. 5.0, The Little Pleasures of Everyday Life—Anecdotes. 5.15, A Leap from an Aeroplane—Reminiscences by the first Woman Parachutist. 5.30, The Funkstunde informs its Listeners. . . . 5.35, Talk: Sport and the Press, from the Viewpoint of a Sports Enthusiast. 6.0, Transmission for all German Stations, relayed from Heilsberg. 7.5 till Close Down, See Heilsberg. 11.0 (approx.), Close Down.

BERNE.—See Schweizerischer Landessender.

BEROMUNSTER.—See Schweizerischer Landessender.

BODEN.—See Stockholm.

BODO.—See Oslo.

### BRATISLAVA

1,073 kc/s, 279.5 metres; 14 kW.—4.5 p.m., Trio Concert. 5.5, Sports Report. 5.20, Recitation. 5.40, Lesson in Telegraphy. 5.55, Hints for Housewives. 6.0, See Prague. 6.10, Talk: The National Holiday of Yugoslavia. 6.25, Flute Duets: Duet, Op. 75 (Mozart); Duet, Op. 2 (Quantz). 6.55, See Prague. 9.30 (approx.), Close Down.

BREMEN.—See Hamburg.

### BRESLAU

923 kc/s, 325 metres; 60 kW. Relayed by Gleiwitz, 1,185 kc/s, 253.1 metres.—1.10 p.m., Gramophone Concert. 1.40, Programme

of Russian Music (Leopold). 3.55, See Prague. 4.5, See Bratislava. 5.5, Talk: Creative Art. 5.15, Talk for Workers. 5.25, German Transmission: Sports Notes, Topical Talk and Literary Review. 6.0, See Prague. 6.25, J. Pleva reads from his own Works. 6.40, Violin Solos by Karel Hanousek. 6.55 till Close Down, See Prague. 9.30 (approx.), Close Down.

### BRUSSELS (No. 1)

I.N.R., 589 kc/s, 509.2 metres; 15 kW.—12 Noon, Gramophone Concert of Variety Music. 1.0 p.m., Le Journal Parlé. 1.10, Concert by the Small Station Orchestra, conducted by Leemans: Overture, The Secret Marriage (Cimarosa); Eine Kleine Nachtmusik (Mozart). 1.20, Soprano Song Recital by Simone de Val: Quo Vadis? (Nongués); Tes yeux (Babey); Scherzo-vaise, Le bouheur (Thiebaut). 1.35, Orchestral Concert (cont'd.), Violin Concerto (Tartini-Chaumont); Trämerei (Schumann); Song without Words (Mendelssohn). 2.0, Broadcast for Schools. 5.0, Concert by the Radio Orchestra, conducted by Franz André. 6.0, Talk: Some Legal Points in Connection with Old Age Pensions. 6.15, Accordion Recital by Thomas Sprimont: Marche militaire (Schubert); Ballet Music from Faust. 6.40, Twelve Mazurkas (Chopin) by Oscar Delvigne (Pianoforte). 7.15, Talk on Telegrams. 7.30, Legal and Literary Talks. 8.0, Concert by the Radio Orchestra, conducted by Franz

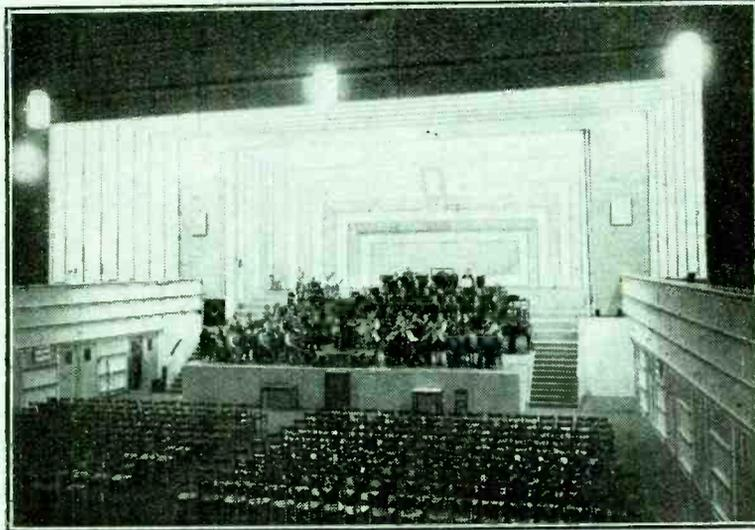

BUILT FOR BROADCASTING. The impressive new concert hall studio at the Deutschlandsender, Berlin, showing the symphony orchestra at rehearsal.

arranged by the Post Office, with Gramophone Records. 2.0, Agricultural Prices. 2.35, Programme for Children. 3.0, Concert by the Station Orchestra, conducted by Rischka. In an interval at 3.45, Humorous Talk, followed by Agricultural Prices. 4.55, Talk: Silesian Dialect. 5.20, Programme to be announced. 5.40, Programme Announcements and Market Prices. 6.0, Transmission for all German Stations, relayed from Heilsberg. 7.0, News. 7.10, Young People in Town and Country—Programme for Country People. 8.0, Concert by the Station Orchestra, conducted by Tiptitz: Rakoczy March; Hungarian Comedy Overture (Keler-Bela); Zigeunerromanze, Debreczin (Meisel); Czardas, Hona (Parkas-Miska); Violin Solo: Czardas (Monti); Pester-Walzer (Lanner); Hungarian Fantasia, Hungaria (Leopold); Hungarian Dances Nos. 5 and 6 (Brahms); Bei der Zigeunerkapelle (Meyer-Helmund); Violin Solo: Zigeunerweisen (Sarasate); Bokreta-Czardas (Keler-Bela); Polonaise No. 2 (Liszt); Song and Czardas (Lehar); Violin Solo: Hejre Kati (Hubay); Chal Romano (Ketelbey); Czardas from Der Geist des Wojewoden (Grossmann); Zigeunerständchen (Neh); Rosza-Czardas (Hubay). In an interval at 9.0, Time and News.

### BRNO

878 kc/s, 342 metres; 35 kW.—3.0 p.m., Concert by the Station Orchestra, conducted by Jan Janota: Overture, Der Waffenschmid (Lortzing); Selection from Much Ado about Nothing (Korngold); Selection from The Flying Dutchman (Wagner); Ballet Intermezzo (Bayer); Medley

André: Overture, Don Pasquale (Donizetti); Good News (Sylvia and Brown); Aragonese (Falla); La cinquantaine (Gabriel Marie); Mazurka naturaliste (Ganne); Songs, Minuet from Orphée (Gluck); Foxtrot, my Darling (Myers); Foxtrot, Call me your only Boy (Bemets); Selection of Negro Spirituals (Foulds). 8.45, Travel Talk. 9.0, Concert by the Station Symphony Orchestra, conducted by Kumps: Soloist, Simone Istace (Songs) and Kalkman (Viola); Norwegian Rhapsody (Lalo); Interlude in Old Style (Glazunov); Humoresque (Frénille); Songs: (a) Aria from L'enfant prodige (Debussy), (b) Romanian Song, (c) Aria from Figaro (Mozart); Piece for Viola and Orchestra (Dupuis); Nursery Suite (Ingebrecht); Persian Dance (Rimsky-Korsakov); Gothic Minuet (Boëllmann); Viennese Waltz (Louque). 10.0, Le Journal Parlé. 10.10, La Brabançonne.

### BRUSSELS (No. 2)

N.I.R., 888 kc/s, 337.8 metres; 15 kW. Programme in Flemish.—12 Noon, Groeninghe (van Hoot), on Gramophone Records, followed by Music by the Small Station Orchestra, conducted by Pierre Leemans. 12.25 p.m., Request Programme: Midnight Tango (Komjati); Selection from The Land of Smiles (Lehar); Schubertiana (arr. Hermann Finek). 12.40, Music by the Small Station Orchestra: Overture, The Gipsy Baron (Joh. Strauss); Violin Solo, Zigeunerweisen (Sarasate); Selection from Zigeunerprimas (Káloian). 1.0, Le Journal Parlé. 1.10, Gramophone Music. 1.30, Gramophone Music. 1.45, Gramophone Music: Czardas (Gross-

mann); Waltz, Acclamation (Waldteufel); March (Haef). 2.0, Broadcast for Schools. 5.0, Concert by the Symphony Orchestra, conducted by Kumps. 5.45, Programme dedicated to St. Nicholas. 7.30, Wireless Notes. 8.0, Gramophone Record: Mijne Moedertaal (Brandts-Buys). 8.5 (approx.), Concert by the Symphony Orchestra, conducted by Kumps. 8.45, Announcements. 8.50, A pleasant Interlude. 9.5, Concert by the Radio Orchestra, conducted by Franz André: Le chant du gondolier (d'Agrèves); Sur l'eau (Desaert); Barcarolle from The Tales of Hoffmann (Offenbach); Waltz (Fetras). 9.25, Paul Lebrun Songs—Recital by Mme. Aerts and M. de Hen: Vlaanderen; Kleine moederke; Zonnevoken; Lentelust. After the Recital, Recitations: Le Sermon d'Eulenspiegel, and Announcements. 9.45, Concert by the Radio Orchestra (cont'd.): Une promenade joyeuse en traineau (Chwatal); Les patins d'or (Weys); The Skaters' Waltz (Waldteufel); De Vlaamsche Leeuw (Miry). 10.0, Le Journal Parlé.

### BUCHAREST

761 kc/s, 394 metres; 12 kW.—4.0 p.m., Concert by the Station Orchestra: March (Brandner-Eppler); Waltz, Dynamiden (Jos. Strauss); Overture, La belle Hélène (Offenbach); Selection from Iris (Mascagni); Serenata d'Amalfi (Bece); Russkaya and Trepak (Rubinstein); Selection from The Duchess of Chicago (Kalman); Ballet Scene, Piazza del Popolo (Fredericksen); Barcarolle (Tchaikovsky); Piece (Dicker); Babilage (Gillet). In the interval at 5.0, Radio Journal. 6.0, Educational Talk. 6.20, Gramophone Music. 6.45, Talk. 7.0, Talk on the following Transmission. 7.10, Polish Festival Concert by the Philharmonic Orchestra, conducted by Fitelberg: Soloist, Szymanowski (Pianoforte); Extract from A Drama at a Masked Ball (Karłowicz-Fitelberg); Symphony No. 4 for Pianoforte and Orchestra (Szymanowski); Extract from the Ballet, Harnasie (Szymanowski); Mazurka from Harka (Moniuszko). In the interval at 8.0, Reading. 8.45, Radio Journal.

### BUDAPEST

545 kc/s, 550.5 metres; 18.5 kW.—Also relayed on 540 metres from 6.30 p.m. till Close Down.—4.30 p.m., Gramophone Music. 5.10, Shortland Lesson. 5.40, Pianoforte Recital by Magda Vasarhelyi. 6.30, Programme relayed from the Royal Hungarian Opera House. News in the interval. After the Relay, Concert of Cigány Music, with Recital of Hungarian Songs, relayed from the Café Emke. 10.0, Talk in French: Charles Lotz.

CASSEL.—See Frankfurt.

### COPENHAGEN

1,067 kc/s, 281 metres; 0.75 kW. Relayed by Kalundborg, 260 kc/s, 1,153.8 metres, and Skamlebaek, OXY, 49.4 metres; 0.5 kW.—11.0 a.m., Time Signal and Chimes from the Town Hall. 11.15, Broadcast for Schools. 11.45, Concert by the Leonard Gylmark String Ensemble, relayed from the Bellevue Strandhotel. 1.0 p.m., Interval. 2.0, Concert by the Mogens Hansen Instrumental Ensemble: Overture, La Cenerentola (Rossini); Algerian Nights (Griegh); Waltz, Le printemps (Waldteufel); Berceuse and Prelude (Järnefelt); Overture, Les Savoyardes (Offenbach); Turkish March (Mozart); Andante cantabile (Tchaikovsky); German Dance (Reger); Intermezzo from L'amico Fritz (Mascagni); Waltz in A (Dvorak); Serenade (Lange-Müller); French Comedy Overture (Kéler-Béla). In an interval at 2.45 (approx.), Reading. 4.0, Programme for Children. 4.30, Exchange and Fish Market Prices. 4.45, Talk: Great Figures of Danish Literature—Bödtecher. 5.15, Elementary German Lesson. 5.45, Weather. 5.54, Announcements. 6.0, News. 6.15, Time Signal. 6.30, Talk. 7.0, Time Signal from the Town Hall. 7.1, Programme by Per Knutzen. 7.10, Recital of Spanish Songs by Else Brems. 7.30, Indivelsen (The Initiation)—Radio Play in One Act (Schlichtkrull). 8.40, Light Music on Gramophone Records. 8.55, News. 9.10, Reading of Danish Poems (Edith Rode). 9.30, Sonata in F, Op. 6 (R. Strauss), for Cello and Pianoforte, played by Rudolf Dietzmann and Walter Meyer-Radon. 10.0, Dance Music by the Aage Juhl-Thomsen Band, relayed from the National Scala. In an interval at 11.0, Time Signal and Chimes from the Town Hall. 11.30 (approx.), Close Down.

CORK.—See Athlone.

DANZIG.—See Heilsberg.

DRESDEN.—See Leipzig.

### FECAMP

1,328 kc/s, 225.9 metres; 10 kW.—11.0 a.m. till 12 Noon, Programme in English by the I.B.C. 11.0, Happy Hour. Part I—Accordion Band. Signature Tune; The best of the bunch (Alexander); Dinah (Lewis); Valse, La Reine (Alexander); Accordion Joe; Song, My Girl ran away (Steinberg); Cuban Mazurka (Alexander); Song, Never too old (Allan); Cocktails (Cuvelier). Part II—Dance Music: The Cage in the window; Ah, but it's love; Sundown in a little Green Hollow; Two Buck Tim from Timbuctoo; Twelfth Street Rag (Buday); Put on your

DEC. 1st

FRIDAY

continued

old grey bonnet (Wenrich); Music hath charms (Harris); Sweet dreams pretty lady (Downey); Signature Tune. 12 Noon, Programme in French. 3.30 to 6.0, Programme in English by the I.B.C. 3.30, Military Music: Overture, Rienzi (Wagner); Wiegand (Brahms); Song, The Old Superb (Stanford); War March of the Priests (Mendelssohn); Song, The Two Grenadiers (Schumann); March (Wagner); Marche militaire (Schubert). 4.0, Dance Music: Signature Tune, Bells of Normandy; A Couple of Pals (Gilbert); My Moonlight Madonna (Fibich); Love's Lane (Miller); Everyone loves my Marguerite (Woods); The Cage in the Window; Sweetheart Darlin'; Lazybones; Solitario; Signature Tune. 4.30, The I.B.C. Nursery Corner: Birthday Greetings; Trumpets. 4.40, Concert for Southampton and Winchester Listeners—From the Cotton Fields: Signature Tune, The Night by the Sea; Down South (Myddleton); Levée Song; O dem Golden Slippers (Bland); The Tiger's Tail (Thurban); By the Swanee River (Myddleton); Poor Old Joe (Foster); Lazy Pete (Kernstein); Deep River (Trad.); Banjo Quartet, Darktown Dandies (Morley); When Malindy Sings (Myddleton); The Watermelon Fete (Myddleton); Plantation Songs Medley. 5.20, Concert for Bournemouth and Weymouth Listeners: Gipsy Music; Black Eyes (Schlerer); Violin Solo, Caprice Viennois (Kreier); C'est l'amour (Pierre); The Gipsies (Higgs); Violin Solo, Hejre Kati (Hubay); Komm Cigany (Kalmán); Hungarian Dance No. 6 (Brahms); Pity Me (Trad.); Spanish Gipsy Dance (Brahms); Hungarian Dance No. 2 (Brahms); March of the Russian Hussars (Trad.); Signature Tune. 6.0, Programme in French. 10.0 (approx.) till Close Down, Programme in English by the I.B.C. 10.0 (approx.), Request Programme: Please (Robin); So long lads, we're off; In the Valley of the Moon (Tobias); How deep is the Ocean? (Berlin); The Sanctuary of the Heart (Ketyelby); Bitter Sweet Waltz (Coward); Play Fiddle, Play. Good-bye (Tosti). 10.30, Dance Music: Signature Tune, The Bells of Normandy; Happy Ending (Parr-Davies); It's not a Secret any more (Blue); Who's afraid of the big bad Wolf? (Churchill); Little Romany (Leon); I've got to get up and go to work (Hupfeld); Si, si (Remy); Oh Johanna (Lawrence); Tick, Toek (Vienna); Signature Tune. 11.0, Talkie Time—Tunes from the Talkies and Shows: Signature Tune, Sittin' in the Dark; Forty Second Street (Dubin); Vilja Song from The Merry Widow (Lehár); Peter (Hollander); Selection from He wanted Adventure (Waller); But for you (Hollander); Selection from The Dubarry (Millöcker-Mackeben); How could we be wrong? (Porter); Live, Love and Laugh (Heymann); Signature Tune. 11.30, Club Concert for Semybridge Listeners. Part I—Gramophone Records. Signature Tune, The Chum Song; Savoy Welsh Medley (arr. Somers); In a country lane (Coates); Sam's Medals (O'Hagan); Wayside Rose (Lehár); Clapham and Dwyer's Fairy Tales; Since you went away (Johnson); Jesu Cyfaill Fenniad (Evans-Perry); Sweet and Low. 12.5 a.m. (Saturday), Late News Bulletin in English. 12.10 (approx.), Club Concert. Part II—Dinner at Eight. My Own; Moths around the candle flame; The Last Round Up; Well done, Gordon (Gilbert); Signature Tune. 12.30, Dance Music: Isn't this a night for love; My Kingdom for a smile from you; Happy as the day is long; For you just you, my baby; If I had someone to love; The Wedding of Mr. Mickey Mouse; Shadows on the Swanee; Elvira. 1.0, Dance Music: Signature Tune, The Bells of Normandy; I've got to pass your house; Aloha Oe; Sing another line; I'll show you off; Dawn in Montmartre; Don't blame me; With you here and me here; Cecilia Mia; It's the talk of the town; Morning, Noon and Night; Forever; Sundown in a little Green Hollow; Adorable; Isn't it heavenly; Nunca; Dear Stranger; Signature Tune. 2.0, I.B.C. Melody and Close Down.

FLensburg.—See Hamburg.

FLORENCE.—See Turin.

FRANKFURT

1,157 kc/s, 259.3 metres; 17 kW. Relayed by Cassel and Trier, 1,157 kc/s, 259.3 metres.—12.15 p.m., Time and News. 12.25, Local News and Weather. 12.35, Concert by the Station Orchestra, conducted by Reinhold Merten. 1.40, Talk for Housewives. 2.30, Weather. 2.40, Time and Economic Notes. 3.0, See Stuttgart. 5.0 to 5.35, See Langenberg. 5.35, Talk: The Claims and Tasks of Socialism. 5.50, Weather and News. 6.0, Transmission for all German Stations, relayed from Heilsberg. 7.0, Topical Talk. 7.10 to 9.0, See Langenberg. 9.0, Time and News. 9.20, See Stuttgart. 9.30, News. 9.45, Concert of Light Music. 10.0, Concert by the Station Orchestra, conducted by Hans Rosband; Soloist: Friedrich Noack (Bass); Part I—Eighteenth Century Music. Part II—Light Music. 11.0, Talk by the Manager of the Frankfurt Broadcasting Stations. 11.10, German Mysticism—Talk on Count Platen. 12 Midnight (approx.), Close Down.

FREDRIKSSTAD.—See Oslo.

FREIBURG.—See Stuttgart.

GENEVA.—See Radio-Suisse Romande.

GENOA.—See Turin.

GLEIWITZ.—See Breslau.

GOTEBORG.—See Stockholm.

GRAZ.—See Vienna.

HAMAR.—See Oslo.

HAMBURG

805 kc/s, 372 metres; 1.5 kW. Relayed by Bremen, 1,112 kc/s, 269.8 metres; Flensburg and Hanover, 1,319 kc/s, 227.4 metres, and Kiel, 1,292 kc/s, 232.2 metres.—4.0 p.m., Variety Programme. 5.0 (from Hanover), Reading (Marlorf). 5.30, Folk Song Sequence on Gramophone Records. 5.45, Frankfurt Exchange and Hamburg Market Prices. 5.50, Weather. 6.0, Transmission for all German Stations, relayed from Heilsberg. 7.5 till Close Down, See Heilsberg. In the interval at 9.0, Time and News.

HANOVER.—See Hamburg.

HEILSBURG

1,085 kc/s, 276.5 metres; 60 kW. Relayed by Danzig, 671 kc/s, 447.1 metres.—12.5 p.m., Gramophone Concert of Variety Music. In the intervals at 12.20 and 1.0, News. 1.30, Programme arranged by the Post Office with Gramophone Records. 2.0, Agricultural Prices and Exchange. 2.15, Programme for Children. 2.40, Programme for Women. 3.0, Concert by the Small Station Orchestra conducted by Eugen Wilcken: Tanz-Szenen-Suite (Richter); Slav Rhapsody (Volpatti); Selection from Das Dorf ohne Glocke (Künneke); Indian Canzonetta (Dvorak); Dance (Dvorak); Overture, William Tell (Rossini); Waltz Intermezzo (Brache); Gruss an Wien (Siede); Selection from The Three Wishes (Zieler); Barbara March (Schlenk). In an interval at 4.0 (approx.), Talk: Sport from a Ski-maker's Point of View. 4.45, Talk on Domestic Animals. 5.15, Agricultural Prices. 5.25, Musical Programme for Children. 5.50, Weather. 6.0, Transmission for all German Stations—Concert of Contemporary Music by the Königsberg Opera House Orchestra, conducted by Erich Seidler: Soloist: Hugo Kolberg (Violin); Festival Prelude (Unger); Violin Concerto in B minor, Op. 57 (Wet); Symphonic Improvisation (Frickhoeffler). 7.0, News. 7.15, The Story of Königsberg Cathedral. 7.45, Concert by the Königsberg Opera House Orchestra, conducted by Wolfgang Brückner: Selection from Salome (R. Strauss); Grotesque Suite for Wood Wind Instruments (Rückert); First Peer Gynt Suite (Grieg); Der Tanz in der Dorfschenke (Liszt); Pesther-Walzer (Lanner); Overture, The Siege of Corinth (Rossini). 8.30, Reading (Irmgard Weithase). 9.0, News. 9.15 (approx.), Concert by the Small Station Orchestra, conducted by Eugen Wilcken: Part I, Italian Music: Overture (Verdi); Ballet Music from La Gioconda (Ponchielli); Selection from The Sunken Bell (Respighi); Dolce Note (Leoncavallo); Venetian Barcarolle (Leoncavallo); Overture, Anne Boleyn (Donizetti). Part II, Variety Music: Overture, Eine Nacht in Venedig (Joh. Strauss); Melodies in Two-Four Time (Geissler); Johann Strauss Potpourri (Fahrhach); Selection from The Little Dutch Girl (Kalman). 11.0 (approx.), Close Down.

HILVERSUM

1,013 kc/s, 296.1 metres; 7 kW. up to 5.40 p.m., and 20 kW. from 5.40 p.m.—11.40 a.m. to 3.40 p.m., Programme of the General Broadcasting Society (A.V.R.O.). 11.40, Time Signal. 11.41, Gramophone Music. 12.10 p.m., Concert of Light Music by Kovacs Lajos and his Orchestra. 2.10, Talk: Marriage in the East. 2.40, Gramophone Music. 3.40 to 7.40, Programme of the Workers' Radio Society (V.A.R.A.). 3.40, Gramophone Music. 4.30, Programme for Children. 5.10, Concert by the V.A.R.A. Orchestra, conducted by de Groot: Overture (Donizetti); Adoration (Filippucci); Italian Street Singers (Niemann); Four Pieces for Orchestra (d'Ambrosio). 5.45, Organ Recital by Jong: Berceuse tendre (Daniderf); Aubade printanière (Lacombe); Selection from The Daughter of the Regiment (Donizetti). 6.5, Gramophone Music. 6.10, Orchestral Concert (cont.): Uncle Teddy (Fueik); Boston (Nick); Two Alsatian Peasant Dances (Merklung); Variations on Le Carnaval de Venice (Ritzau). 6.40, Talk. 6.55, Accordion and Pianoforte Recital: Flapperette (Greer); The Wedding of the Winds (Hall); Fourth Hungarian Dance (Brahms); Los Banderillos (Volpatti). 7.10, Orchestral Concert (cont.): Die Musik kommt (Strauss); Waltz Scherzo (Strauss); Walzer-Redoute (Hildebrandt); Selection from the Music to Cavalcade (Coward). 7.40 to 10.40, Programme of the Liberal Protestant Radio Society (V.P.R.O.). 7.40, Religious Address. 8.10, Song and Pianoforte Recital: Aria from Judas Maccabaeus (Händel); Aria from Joshua (Händel); Aria (Graun); Pianoforte Solos: (a) Caprice, (b) Fantasia (Händel); Songs: (a) Das Veilchen, (b) An Chloë (Mozart), (c) Frühlingsglaube (Schubert), (d) Auf dem Wasser zu singen (Schubert). 8.40, Talk: The Church in Modern Times. 9.10, Song and Pianoforte

Recital (cont.): Songs: (a) Aubade (Bizet), (b) Les Vendanges (Saint-Saëns); Pianoforte Solos: (a) Allegro appassionata (Saint-Saëns), (b) L'Isle joyeuse (Debussy); Songs: (a) Traum durch die Dämmerung (Richard Strauss), (b) Du meines Herzens Kronelein (Richard Strauss), (c) Wer hat dies Liedlein erdacht? (Mahler). 9.40, News. 9.55, Talk: Shakespeare's Tragedies—King Lear. 10.25, Gramophone Music. 10.40 till Close Down, Programme of the V.A.R.A. Gramophone Concert. 11.40 (approx.), Close Down.

HORBY.—See Stockholm.

HUIZEN

160 kc/s, 1,875 metres; 7 kW. until 3.40 p.m.—Transmitted from Kootwijk on 50 kW. from 3.40 p.m.—Programme of the Catholic Radio Society (K.R.O.). 11.40 a.m., Concert by Fabian and his Orchestra: Selection from William Tell (Rossini); You are the Girl for me (Sorge); Life is good (Michele); White Jazz (Casaloma); Melody (Grothe); Vision of Love; Potpourri, Von Wien durch die Welt (Hrubly); Gramophone Music; The Rosary (Nevin); Lazybones (Mercer); Air (Brodsky); A Fête in Aranjuez (Demersmann); Melody. 1.40 p.m., Gramophone Music. 2.40, Recitations. 3.0, Gramophone Music. 3.15, Recitations (cont.). 3.40, Interval. 3.55, Gramophone Music. 4.55, Concert by the K.R.O. Boys, conducted by Lustenbouwer. In the interval at 5.40, Talk: The Red Cross. 6.40, Police Notes. 6.55, Talk. 7.15, Gramophone Music. 7.25, Talk on Astronomy. 7.40, Music by the K.R.O. Boys. 8.10, Press Review. 8.15, Stemenen nit ons aller Jeigt—Radio Play (Roekenbach); Translation by Bekkers. 9.0, Concert by the K.R.O. Orchestra, conducted by Gerritsen. Soloist: Mlle. Hans Gruys (Mezzo-Soprano). Overture to Goethe's Faust (Schumann); Prayers (Caplet); Selection from Raymond (Glazunov); Suite algérienne (Saint-Saëns). 9.40, Gramophone Music. 9.55, Concert (cont.): Overture, Le Baruffe Chiozzotte (Sinigaglia); Five Spanish Airs (arr. Schuurman); Three Spanish Dances (Graudaux); Piece in Three-Four Time (Wagenaar). In the interval at 10.25, News. 10.40, Gramophone Music. 11.40 (approx.), Close Down.

INNSBRUCK.—See Vienna.

JUAN LES PINS

NICE, 1,205 kc/s, 249 metres; 0.8 kW.—8.0 p.m., Amusement Guide, Exchange and News. 8.10, Esperanto Lesson. 8.25, Concert. 9.0, News and Weather. 9.15, Concert. 10.30, Special Transmission for Central Europe: Concert. Military March (Jurek); Joys of Spring (Alibout); Dance of the Grasshoppers (Bucalossi); Der Rosenhochzeitzug (Jessel); The Druids' Prayer (Davson); Dreaming (Joyce); Le dindon dans la paille (Cuion); Irish Melody (arr. Sowerby); Serenade (Heykens); Song, The Broken Heart (Moya); American Suite (Thurban); Uncle Pierrot (Burnley Jones); Jollification (Reever); Old Popular Melodies; Melody (Pollito); Good-bye, Argentina (Rodriguez); Vivienne (Finck); Longing (Haydn-Wood); Song of the Volga Boatmen; Shining Moon; Hungarian Melodies (Leopold); Idylle bohémienne (arr. Ferraris); Fantasia (Kalmán); Romanian Fantasia (Stefanescu); Wine, Woman and Song (Joh. Strauss); Frühlingsstimmen (Strauss).

KALUNDBORG.—See Copenhagen.

KIEL.—See Hamburg.

KLAGENFURT.—See Vienna.

KOSICE.—See Prague.

LANGENBERG

635 kc/s, 473 metres; 60 kW.—12.15 p.m., See Frankfurt. 12.25, News and Weather. 12.35, See Frankfurt. 2.0, Soprano Song Recital by Anni Beuthel, with Pianoforte and Violin Accompaniment. 2.15, Talk: Excursions in the Rhineland and Westphalia. 2.30, Economic Notes. 2.50, Political Announcements. 3.0, Concert from Stuttgart. 5.0, English Conversation Lesson. 5.20, Talk on Genealogy. 5.35, Gramophone Music. 5.50, Announcements. 6.0, Transmission for all German Stations, relayed from Heilsberg. 7.0, See Frankfurt. 7.10, A Journey through Westphalia—Radio Pictures (Rudolf Predeck). 8.10, Dance Music by the Station Band, conducted by Kühn. 9.0, See Frankfurt. 9.20, See Stuttgart. 9.30, News. 9.45, A Flying Visit. 10.0 till Close Down. See Frankfurt. 12 Midnight (approx.), Close Down.

LAUSANNE.—See Radio-Suisse Romande.

LEIPZIG

770 kc/s, 389.6 metres; 120 kW. Relayed by Dresden, 941 kc/s, 319 metres.—12.30 p.m., Arias from Opera on Gramophone Records. 1.15, News. 1.30, Art Report. 2.15, Programme for Women. 2.35, Market Prices. 3.0, Concert by the Station Orchestra, conducted

by Hilmar Weber: Three Movements from Tafelmusik (Telemann); Ein musikalischer Spass (Mozart); Second Movement from the Military Symphony (Haydn); Allegretto scherzando from the Eighth Symphony (Beethoven); Ballet Music from Rosamunde (Schubert). 4.0, Books for the Hitler Jugend. 4.25, Talk: Gothic Architecture in North Germany. 4.50, Concert by the Roma Trio. 5.40, Economic Notes and News. 6.0, Transmission for all German Stations, relayed from Heilsberg. 7.0, Der Wildschütz—Opera in Three Acts (Lortzing). 9.0, News. 10.0, Concert Relay. 11.0 (approx.), Close Down.

LINZ.—See Vienna.

LUXEMBOURG

252 kc/s, 1,191 metres; 200 kW. Dutch Evening.—7.0 p.m., Gramophone Concert: Overture Anacréon (Cherubini); Symphony No. 4 (Tchaikovsky). 7.55, Concert by the Station Orchestra, conducted by Pénis: Overture, Hamlet (Bach); Le jeune Berger (Marsick); Selection from Andrea Chenier (Giordano); Berceuse (Vreuls); Feather Waltz (Lanner); Les joyeuses Filenses (Gillet); Badinage (Jongen). 8.50, News in French. 9.0, Dichtertjebe (Schumann)—Song Recital by Gustave Simon. 9.35, Concert by the Station Orchestra, conducted by Pénis: Prologue to I Pagliacci (Leoncavallo); Eleyk (Massenet); Waltz, O Frühling wie bist du so schön (Lincke); Gräud'mann (Lauge); Oriental Suite (Popy). In the interval at 9.50, News in German. 10.25, Dance Music on Gramophone Records.

MADRID

ARANJUEZ (EAQ), 10,000 kc/s, 30 metres; 10 kW.—10.30 p.m., Concert of Popular Music. In the interval at 10.45, Radio Chronicle. 11.45, Light Music. 12 Midnight till Close Down, I.B.C. Concert of Dance Music: P.C. 123 (Munroe); Peter, Peter (Connelly); Two Buck Tim (Goodhart); Sweetheart Darlin' (Kalm); Street of Dreams (Lewis); Yes, Mr. Brown (Abraham); Avalon (Jolson); One Tiny Tear (Connelly). 12.30 a.m. (Saturday), I.B.C. Goodnight Melody and Close Down.

MADRID

EAJ7, 707 kc/s, 424.3 metres; 2 kW.—7.0 p.m., Chimes, Exchange, Announcements, Programme for Women, and Dance Music. 8.15, Radio Journal. 8.30 to 9.30, Interval. 9.30, Chimes, Time and Radio Journal. 9.45 (approx.), Aida—Opera (Verdi) on gramophone Records. 11.45, Radio Journal and Programme Announcements for Listeners Abroad. 12 Midnight, Chimes and Close Down.

MALMO.—See Stockholm.

MILAN.—See Turin.

MORAVSKA-OSTRAVA

1,137 kc/s, 263.8 metres; 11 kW.—5.15 p.m., See Prague. 6.40, Chromatic Accordion Music. 6.55 till Close Down, See Prague. 9.30 (approx.), Close Down.

MOSCOW

KOMINTERN (RWC), 202.5 kc/s, 1,481 metres; 500 kW.—3.30 p.m., Educational Talk: Capital. 4.30, Red Army Programme. 5.30, Programme for Collective Farm Workers. 6.30, Talk: Fascism. 7.0, Concert. 8.0, German Programme. 8.55, Chimes from the Red Square. 9.5, Programme in English. 10.5, Programme in Czech.

MOTALA.—See Stockholm.

MUHLACKER.—See Stuttgart.

MUNICH

563 kc/s, 533 metres; 1.5 kW. Relayed by Augsburg and Kaiserslautern, 536 kc/s, 560 metres; and Nürnberg, 1,256 kc/s, 239 metres.—3.30 p.m., Concert by the Station Orchestra, conducted by Karl List. Soloist: Willy Stühlfant; Leonora Overture No. 2 (Beethoven); Violin Concerto (Mojszowicz); Ballet Music from Czar and Carpenter (Lortzing); Waltz (Reger); Selection from Tiedland (d'Albert); Waltz, Bei uns z' Haus (Joh. Strauss); Triumphant March from Aida (Verdi). 4.30, Reading (Paul de Luzarde). 4.45, Programme for the Younger Generation. 5.5, Pianoforte Recital by Fritz Hübsch and Ludwig Schmidmeier: Nocturne, Op. 77 (Renner); Intermezzo in E flat minor, Op. 45, No. 3 (Reger); Waltzes from Waltz Duets (Eiseman). 5.25, Illustrated Talk: Old Germanic Musical Instruments. 5.45, Time and Announcements. 6.0, Transmission for all German Stations, relayed from Heilsberg. 7.0, Programme to be announced. 8.0, Political Address. 8.20, New Viennese Musical Comedy—Extracts with Commentary. 9.0, Time and News.

NAPLES.—See Rome.

NOTODDEN.—See Oslo.

OSLO

277 kc/s, 1,083 metres; 60 kW. Relayed by Fredriksstad, 815 kc/s, 368.1 metres; Hamar, 522 kc/s, 574.7 metres; Notodden, 671 kc/s, 447.1 metres; Porsgrund, 662 kc/s, 453.1 metres; Rjukan, 671 kc/s, 447.1 metres, and Jely (LCL), 6,990 kc/s, 42.92 metres.—4.0 p.m., Concert relayed from the Hotel

DEC. 1st **FRIDAY** continued

Britannia, Tröndelag. 5.0, French Lesson. 5.30, Talk: Are you Superstitious? 6.0, Announcements, Weather and News. 7.0, Time Signal. 7.1, Concert by the Philharmonic Orchestra, conducted by Harald Heide. Soloist: Helga Lökke (Violin). Spanish Caprice (Rimsky-Korsakov); Pan and Syrinx (Nielsen); Violin Concerto in B minor (Saint-Saëns); Rondo Infinito (Sinding). 8.30, Agricultural Report, Weather and News. 9.0, Topical Talk. 9.15, Variety Programme. 9.45 (approx.), Close Down.

**OSTERSUND.**—See Stockholm.

**PALERMO**

556 kc/s, 539.5 metres; 3 kW.—7.0 p.m., Dopplavoro Announcements, Tourist Talk, Agricultural Notes, Report of the Royal Geographical Society and Giornale Radio. 7.20, Gramophone Music. In the interval at 7.30, Time and Announcements. 7.45, Symphony Concert, conducted by Armando la Rosa Parodi. Soloist: Lea Tumbarello Mulè (Pianoforte); Pianoforte Concerto in E Flat (Liszt); Summer Concerto (Pizzetti); Symphony Poem, Don Juan (R. Strauss). In the interval: Talk. After the Concert: Light Music on Gramophone Records. 10.0, Giornale Radio.

**PARIS**

**EIFFEL TOWER, Call FLE,** 207.5 kc/s, 1,445.7 metres; 13 kW. Time Signals (on 2,650 metres) at 9.26 a.m. and 10.26 p.m. (Preliminary and 6-dot Signals).—5.45 p.m., Le Journal Parlé. 7.15, Weather. 7.25, News. 7.30, Pianoforte Recital with Commentary: Twelve Mazurkas (Chopin). 8.0, Political Review. 8.15, Orchestral Concert, conducted by Flament: Soloists: Charou (Violin), Manouvrier (Flute), and Marchesini (Cello); Sicilienne (Bach); Bourrée (Bach); Violin Solos; Dans les cygnes (Flament); Flute Solos; Albumblatt (Wagner); Serenade, L'amant jaloux (Grétry); Cello Solos; Slav Dances (Dvorak). 9.9 (approx.), Close Down.

**PARIS**

**POSTE PARISIEN,** 914 kc/s, 328.2 metres; 60 kW.—7.0 p.m., Gramophone Music. 7.5, Sponsored Talk. 7.15, Le Journal Parlé. 7.30, Extracts from the Sonata for Violin and Pianoforte (Frank), by Lucien Bellanger and Maurice Béché. 7.55, Review of the week. 8.0, Talk on Music. 8.10, Interval. 8.30, Fortunio, Opéra-Comique in Three Acts (Messager), on Gramophone Records. 10.30, News.

**PARIS**

**RADIO-PARIS, Call CFR,** 174 kc/s, 1,725 metres; 75 kW.—6.45 a.m., Physical Culture. 7.30, Weather and Physical Culture (contd.). 7.45, Gramophone Music. 8.0, Press Review and News. 12 Noon, Jewish Talk. 12.30, Gramophone Music: Overture, The Secret Marriage (Cimarosa); Eglogue (Raboud); Alborada del gracioso (Ravel); Le rouet d'Omphale (Saint-Saëns); Les chants de la mer (Gaubert); Overture, Ramuntcho (Piéridé); Marche écossaise (Debussy); Selection from the Love of the Three Oranges (Prokofiev). In the interval at 1.0, Exchange, News, and Weather, and at 1.30, Exchange. 2.0, Exchange and Announcements. 3.45, Exchange and Market Prices. 4.30, Elementary English Lesson. 6.20, Agricultural Talk. 6.45, Report of Social Assurance Societies. 7.0, Book Review. 7.20, Gramophone Music: Moi je n'fiche rien (Borel-Clerc); Pluie de roses (Avignon); Leila (Dauber); Les papillons de nuit (Gaborché); Sautez béhés (Paradis). 7.35, Popular Music: Madrid (Alex); Je sais que vous êtes jolie (Christine); Fleche d'or (Vacher); Deux guitares (arr. Weismann); En avant (Mateo). 7.50, Commercial Notes and News. 8.0, Readings. 8.30, News and Weather. 8.40, Gastronomic Talk. 8.45, The Proposal—Play (Tehekov). In the interval at 9.15, Press Review and News. 9.30, Piano Recital by Jean Doyen. 10.0, Variety Programme. Part I—Recitations to Music; Part II—Gramophone Music.

**PITTSBURGH**

**KDKA,** 980 kc/s, 306 metres; 50 kW. Relayed by WXXK on 48.86 metres and 25.27 metres.—7.0 p.m., Musical Originalities, from New York. 7.30, KDKA Home Forum. 8.0 to 9.30, New York Relay. 8.0, U.S. Marine Band. 9.0, Betty and Bob. 9.15, Gene Quaw's Orchestra. 9.30, News and Market Reports. 9.45, Variety Programme. 10.0, Uncle Tom and Betty. 10.15, KDKA Kiddies' Klub. 10.30, The Singing Lady, from New York. 10.45, Orphan Annie, from New York. 11.0, News-Reeler, Pat Haley. 11.15, Sports and Programme Preview. 11.30, Even-song. 11.45, Lowell Thomas, from New York. 12 Midnight, Amos 'n' Andy, from New York. 12.15 a.m. (Saturday), The Silver Toppers. 12.30 to 3.30, New York Relay. 12.30, Potash and Perlmutter. 12.45, Irene Rich for Welch. 1.0, Popular Programme. 1.30, Dangerous Paradise. 1.45, Red Davis. 2.0, Let's listen to Harris. 2.30, Variety Programme. 3.0, The Iron Master.

**PORSGRUND.**—See Oslo.

**PRAGUE**

314 kc/s, 488.6 metres; 120 kW.—3.0 p.m., See Brno. 3.55, Talk. 4.5, See Bratislava. 5.5, Agricultural Talk. 5.15, Talk for Workers. 5.25, News in German. 5.30,

German Transmission—Talk: The Electrification of the Railways. 6.0, Time, News and Weather. 6.10, English Conversation Lesson. 6.25, Topical Talk. 6.40, Saxophone Recital by Vilém Fleischbans: Aria from La Juive (Halévy); Aria from Eugene Onegin (Tchaikovsky); Aria from In the Well (Bödeker); Ave Maria (Gounod); Humoresque (Potuznik); Aria from Rousalka (Dvorak). 6.55, Talk: The Yugoslav National Holiday. 7.5, Concert for the Yugoslav National Holiday, relayed from the Smetana Hall. 7.40, Recital of Modern Yugoslav Poetry. 8.10, Concert of Yugoslav Music by the Station Orchestra, conducted by Otakar Parík. 9.0, Time, News, Review of the Day, and Sports Notes. 9.15, News in Russian. 9.30 (approx.), Close Down.

**RADIO-SUISSE ROMANDE**

**SOTTENS,** 743 kc/s, 403 metres; 25 kW; and Geneva, 400 kc/s, 749.9 metres.—6.0 to 6.15 a.m. (from Lausanne), Gymnastics. 11.28, Time Signal from Neuchâtel Observatory. 11.30, News and Weather. 11.40 (from Geneva), Gramophone Concert. 12 Noon (from Geneva), Financial Notes. 12.10 p.m. (from Geneva), Gramophone Concert (contd.). 1.0, Interval. 2.58, Time Signal from Neuchâtel Observatory. 3.0, See Schweizerischer Landessender. 5.0 from Geneva, Programme for Women. 5.30 from Geneva, Esperanto Lesson. 5.40 from Geneva, English Lesson. 6.5 (from Geneva), Talk for Bridge Players. 6.20 (from Geneva), Talk for Chess Players. 6.35 (from Geneva), Illustrated Talk: Newly-released Gramophone Records. 6.59 (from Geneva), Weather Report. 7.0 (from Geneva), Concert of Modern Chamber Music by the Klein Quartet. 7.40 (from Geneva), Humorous Programme. 7.55 (from Geneva), Cabaret Programme. 8.50, News and Weather. 9.0 (from Geneva), Report of the Touring Club, and Road Report. 9.10 (from Geneva), Answers to Correspondence. 9.30 (approx.), Close Down.

**RJUKAN.**—See Oslo.

**ROME**

**Call IRO,** 680 kc/s, 441 metres; 50 kW. Relayed by Naples, 941 kc/s, 319 metres; Milan (Vigentino), 662 kc/s, 453.1 metres, from 7.15 p.m.; and **2RO,** 11,810 kc/s, 25.4 metres.—12 Noon to 1.15 p.m., Orchestral Concert. In the intervals from 12.30 to 12.45, Giornale Radio and Exchange, and at 1.0, Time and Announcements. 3.0, Song Recital by Bidu Sayao (Soprano), relayed from the Royal Academy of Saint Cecilia. 5.40 (Naples), Shipping and Sports Notes. 5.45, Dopplavoro and Tourist Reports. 5.57, Report of the International Institute of Agriculture (in Spanish, German and French). 6.10, Wheat Market Report. 6.20, News in Foreign Languages. 6.40, Giornale Radio. 7.0, Time, Announcements and Sports Notes. 7.15, Sponsored Concert. 8.15, La giornata di Marcellina—Opera in Three Acts (Attilio Parelli). Talk and News in the intervals. Giornale Radio after the Opera.

**SALZBURG.**—See Vienna.

**SCHENECTADY**

**WGY,** 790 kc/s, 379.5 metres; 50 kW. Relayed at intervals by WXXAF on 31.48 metres and by WXXAD on 19.56 metres.—7.30 p.m., Friday Steeplechase, from New York. 8.15 to 8.30 (approx.), Georgia Wildcats. 12.45 a.m. (Saturday), Trials of the Goldbergs, from New York. 1.0, Cities Service Programme, from New York. 1.30, Popular Programme. 2.0 to 4.0, New York Relay. 2.0, Variety Programme. 3.0, First Nighters. 3.30, Popular Programme. 4.0, Programme Résumé.

**SCHWEIZERISCHER LANDESENDER**

**BEROMUNSTER,** 653 kc/s, 459 metres; 60 kW.; Basle, 1,229 kc/s, 244.1 metres; and Berne, 1,220 kc/s, 245.9 metres.—5.50 a.m. to 6.5 (from Zürich), Skiing Lesson. 11.0 (from Basle), The Don Cossack Choir (on Gramophone Records). 11.29, Time Signal from the Neuchâtel Observatory. 11.40 (from Basle), Music by the Alexandrov Ballet Orchestra. 12.25 p.m. (from Basle), Time, Weather and Exchange. 2.30 (from Basle), Talk: The School Child. 3.0 (from Zürich), Folk Music of the Argentine, Chile, Peru and Mexico. 3.30, Concert by the Station Orchestra. 4.0, Gramophone Records. 4.10, Concert of Viennese Music by the Small Station Orchestra, conducted by Scheerbaum. 5.0 (from Zürich), Gramophone Concert. 5.30 (from Berne), Programme to be announced. 6.0 (from Berne), Time, Weather, Exchange, Tourist Report and Winter Sports Notes. 6.25 (from Berne), Popular Concert. 7.5 (from Berne), Dialogue. 7.35 (from Berne), Variations and double Fugue on a Theme of Bach (Reger), played by Franz Josef Ilirt. 8.0, Weather and News. 8.10 (from Berne), Programme

to be announced. 9.15 (from Berne), Diaclet to Programme. 9.25 (approx.), Close Down.

**SOTTENS.**—See Radio-Suisse Romande.

**STOCKHOLM**

699 kc/s, 436 metres; 55 kW. Relayed by Boden, 242 kc/s, 1,239.5 metres; Göteborg, 932 kc/s, 322 metres; Hörby, 1,167 kc/s, 257 metres; Motala, 222.5 kc/s, 1,348 metres; Östersund, 402 kc/s, 746.2 metres; and Sundsvall, 554 kc/s, 542 metres.—12 Noon to 12.25 p.m., Broadcast for Schools, relayed from Malmö, 1,301 kc/s (230.6 metres). 4.5, Swedish Boy Scouts' Report. 4.25, Accordion Music. 4.45, The Practical Corner. 5.0, Gramophone Music. 5.55, Talk on Foreign Politics. 6.15, Weather and News. 6.30, Songs from Operetta. 6.50, Talk. 7.0, Concert by the Students' Choral Society, conducted by Einar Ralf, relayed from The Academy of Music. 7.45, Literary Discussion. 8.45, Weather and News. 9.0, Concert by the Göteborg Chamber Orchestra, conducted by Tor Mann: Soloist: John Järnberg (Violin); Symphony No. 3 in C (Bach); Violin Concerto No. 2 in G Minor (Vivaldi); Angelus (Liszt); Serenade for Strings, Op. 20 (Hennberg). 10.0 (approx.), Close Down.

**STRASBOURG**

869 kc/s, 345 metres; 11.5 kW.—11.30 a.m., Gramophone Concert. 12.45 p.m., News. 1.0, Time and Exchange. 1.5, Gramophone Music. 2.0, Interval. 4.45, Talk on Literature: Marie Bashkirtzev. 5.0, Concert by the Station Orchestra, conducted by Roskam: Overture, A Night in Venice (Joh. Strauss); Waltz, Ange d'amour (Waldteufel); Viola Solo; Selection from La Bohème (Puccini); Song (Schubert); Ave Maria (Schubert); Berceuse (Masseenet); Selection from The Lust Waltz (O. Straus). 6.0, Trio Concert, relayed from Lille, 1,128.5 kc/s, 265.8 metres. 7.0, Topical Talk in German. 7.15, Talk in German: Franco-German Trade. 7.30, Time and News. 7.45, Gramophone Music. 8.0, Press Review in German. Lottery Results, and Announcements. 8.30, Orchestral Concert: Soloists: Hastin (Baritone), Pagoda (Pianoforte), and Jean Weber (Saxophone); Overture, The Thieving Magpie (Rossini); Pianoforte Solo Scherzo in B minor (Chopin); Selection from Lakmé (Delibes); Songs: (a) Serenade from Milenka (Blockx); (b) Tes yeux (Rahey); (c) Tout doucement (de Fontenailles); Song of the Bees (Filippucci); Orientale for Saxophone and Pianoforte (Spork); Melodies from White Horse Inn (Stolz); Songs (Grabbe): (a) Dans ton miroir, (b) Rubbica, (c) Flemish Cradle Song; Song Foxrot: Stay out of my Dreams (Washington-Petkera); Selection from No. No. Nanette (Youmans); Tango from White Horse Inn (Stolz-Benatzky); Song Foxrot: Good evening, Mr. Nightingale (Pallack-Seymour); Intermezzo, Babil (Momaert); Two-Step, Carumba (de Bozi). In the interval at 9.30 (approx.), Press Review in French. 11.30 (approx.), Close Down.

**STUTTART**

**MUHLACKER,** 832 kc/s, 360.5 metres; 1.5 kW. Relayed by Freiburg, 527 kc/s, 570 metres.—12.15 p.m., See Frankfurt. 12.25, Local News and Weather. 12.35, See Frankfurt. 3.0, Concert by the Small Station Orchestra, conducted by Schröder: Overture, Preciosa (Weber); Suite No. 1 from Carmen (Bizet); Strings and Harp: Romance (Schröder); Selection from Madame Butterfly (Puccini); Hungarian Rhapsody No. 11 (Liszt); Ballet Music from Sylvia (Delibes); Waltz, Wiener Blut (Joh. Strauss); Two Songs (Grieg): (a) Letzter Frühling, (b) Herzwunden; Rhapsody on Swabian Folk Songs (Kämpfert). 5.0 to 5.35, See Langenberg. 5.35, Legal Talk. 5.45, Time and Announcements. 6.0, Transmission for all German Stations, relayed from Heilsberg. 7.0, See Frankfurt. 7.10, See Langenberg. 9.0, See Frankfurt. 9.20, Talk: Things you should know. 9.30, Local News. 9.45 till Close Down, See Frankfurt. 12 Midnight (approx.), Close Down.

**SUNDSVALL.**—See Stockholm.

**TOULOUSE**

779 kc/s, 385 metres; 8 kW.—6.0 p.m., News. 6.15, Dance Music. 6.30, Tourist Talk. 6.45, Songs. 7.0, Medical Talk. 7.15, News, Exchange and Market Prices. 7.30, Concerto in C minor for Harp and Orchestra (René). 7.45, Accordion Solos. 8.0, Operetta Music. Arias from Phi-Phi (Christine), Fortunio (Messager), Les saltimbanques (Ganne) and Tip-Toes (Gershwin). 8.15, Opera Music. Introduction and Entr'acte from The Tales of Hoffmann (Offenbach); Meditation from Thaïs (Massenet); Entr'acte from Carmen (Bizet); Selection from La Bohème (Puccini). 8.30, Tango Songs. 8.45, Light Music by a Viennese Orchestra. 9.0, Concert of Opera Music: Overture, Le roi d'Ys (Lalo); Liberté O liberté ma mie, from Le jongleur de Notre Dame (Massenet); The Legend of Adamastor, from L'Africaine (Meyerbeer);

Aria from I. Pagliacci (Leoncavallo); Duet from Werther (Massenet); Aria from La Favorita (Donizetti); Gavotte from Mignon (Thomas). 9.30, Orchestral Music: Danse des sylphes (Berlioz); Hungarian Dance No. 1 (Brahms); Selection from Schwanda the Piper (Weinberger). 9.45, Music from Sound Films. 10.0, Hawaiian Guitar Solos. 10.15, News. 10.30, Concert for Listeners in Morocco, Part I. Choral Music. Part II. Orchestral Music. 11.0, Chansonnettes. 11.15, Dance Music. 12 Midnight, News, Weather and Announcements. 12.5 a.m. (Saturday), Orchestral Music: Invitation to the Waltz (Weber); Carnaval romain (Berlioz); Jubel-Ouverture (Brahms). 12.30 (approx.), Close Down.

**TRIESTE**

1,211 kc/s, 247.7 metres; 10 kW.—4.10 p.m., Concert of Chamber Music; Carlo Kuhnacevich (Violin), Bruno Bidussi (Pianoforte), Roberto Repini-Sesso (Cello), and Corrado Valdisseri (Viola); Trio for Strings, Op. 38. No. 2 (Hoecherimi); Sonata No. 17 in A for Violin and Pianoforte (Mozart); Quartet in E Flat, Op. 47 (Schumann). 5.0 till Close Down, See Turin.

**TRONDHEIM.**—See Oslo.

**TURIN**

1,096 kc/s, 273.7 metres; 7 kW. Relayed by Milan, 903 kc/s, 332.2 metres; Genoa, 959 kc/s, 312.8 metres; and Florence, 598 kc/s, 501.6 metres.—4.10 p.m., Concert of Chamber Music. 5.0 to 5.5, Weather. 5.40, Giornale Radio, Dopplavoro Report and Gramophone Music. 6.0, Time, Report of the Royal Geographical Society, and Gramophone Music. 6.10, Wheat Market Report. 6.20, News in Foreign Languages. 6.40, Gramophone Music. 7.0, Giornale Radio and Weather. 7.15, Gramophone Music. 7.30, An Operetta in Three Acts. Talk and News in the intervals. Giornale Radio after the Operetta.

**VATICAN CITY**

15,120 kc/s, 19.84 metres (Morning) and 5,969 kc/s, 50.26 metres (Evening); 10 kW.—10.0 to 10.15 a.m., Religious Information in German. 7.0 to 7.15 p.m., Religious Information in Italian.

**VIENNA**

580 kc/s, 517.2 metres; 100 kW. Relayed by Graz, 852 kc/s, 352.1 metres; Innsbruck, 1,058 kc/s, 283 metres; Klagenfurt, 622 kc/s, 453.1 metres; Linz, 1,220 kc/s, 245.9 metres; and Salzburg, 1,373 kc/s, 218.5 metres.—10.30 a.m., Orchestral Concert, conducted by Gustav Macho. In the interval at 10.55, Weather. 12 Noon, Time and News. 12.10 p.m., Famous Artists on Gramophone Records. 1.0, Interval. 2.0, Time and Exchange. 2.15, Programme for Children. 2.40, Gramophone Concert by the Jaroff Don Cossacks Choir. 3.35, Programme for Women. 3.55, Talk: The Italian Theatre. 4.15, Reading (Eybner). 4.25, Soprano Song and Aria Recital by Olga Kalliwoda. 4.55, Tourist Report. 5.10, Talk on Ski Jumping. 5.25, Sports Notes. 5.35, Talk: An Austrian Reformatory for Young People. 6.0, Concert by the Wiener Symphoniker, conducted by Josef Holzer. In an interval at 6.35, Time and Announcements. 7.5, Readings. 7.45, Snow Report. 7.55, Concert by the Wiener Symphoniker, conducted by Carl Alwin. Soloist: Anton Kamper (Violin); Overture, Der Schauspieler (Mozart); Violin Concerto in G (Mozart); Four Symphonic Entr'actes from Intermezzo (R. Straus); Chamber Suite for Sixteen Instruments (Salmhofer); Symphonic Poem, Mazepa (Liszt). 9.0, Topical Talk. 9.15, News. 9.30, Concert of Light Music by the Four Funny Fellows, relayed from the Oase. After the Concert, Announcements.

**WARSAW**

212.5 kc/s, 1,411 metres 120 kW.—10.57 a.m., Time Signal and Fanfare from St. Mary's Church, Cracow. 11.5, Orchestral Concert, conducted by Raczynski. 11.30, Radio Journal. 11.35, Weather. 11.38, Orchestral Concert (contd.). 12 Noon, Interval. 2.25, News and Economic Notes. 2.40, Dance Music on Gramophone Records. 3.10, Vocal Duets by Jeanne Slonska (Mezzo-Soprano) and Lilian (Soprano). 3.40, Book Review. 3.55, Instrumental Concert: André Kalinowsky (Clarinet) and Rosenbaum (Pianoforte). Clarinet and Pianoforte: Sonata in F minor, Op. 130 (Brahms); Pianoforte Solos: (a) Intermezzo in E flat minor (Schumann), (b) The Miller and the Stream (Schubert-Liszt), (c) Capriccio in B minor (Brahms), (d) Mazurka in E flat minor (Chopin), (e) Nocturne in E (Chopin); Air and Gigue (Leclair); Five Pieces (Debussy): (a) La fille aux cheveux de lin, (b) Petite Piece, (c) Arabesque No. 2, (d) Valse triste, (e) La coquette. 4.50, Agricultural Talk. 5.20, Orchestral Concert. 6.0, Programme Announcements. 6.5, Miscellaneous Announcements. 6.20, Talk: Suggestions for Holidays. 6.25, Topical Talk. 6.40, Sports Notes. 6.47, Radio Journal. 6.55, Interval. 7.0, Talk on Music. 7.15, Concert by the Philharmonic Orchestra and the Chopicki Viennese Choir. Part I—Abu Hassan—Comic Opera (Weber). Part II—Choral Songs. In the interval at 8.0, Literary Talk. 9.40, Dance Music by the Henri Gold Band, relayed from the Femina Cabaret. In an interval at 10.0, News.

**ZURICH.**—See Schweizerischer Landessender.

# SATURDAY

## DECEMBER THE SECOND

### ALGIERS

825.5 kc/s, 363.3 metres; 13 kW.—7.0 p.m., Financial Notes. 7.10, Shipping Notes. 7.15, Agricultural Notes and Weather Report. 7.20, Operetta Arias. 7.55, News. 8.0, Time Signal. 8.2, Concert by the Station Orchestra. Overture Alessandro Stradella (Flotow); Waltz (Liollaender); La jolie Persane (Leococq); Jeux de naiades (Dargel); En Bretagne (Rhené-Baton). In the interval at 8.30, News and Light Music. 9.30, News. 9.35, Recitations. 9.55, News.

### ATHLONE

725 kc/s, 413 metres; 60 kW. Relayed by Dublin, 1,322 kc/s, 217 metres, and Cork, 1,337 kc/s, 224.4 metres.—1.30 to 2.30 p.m., Time Signal. Weather Report, Stock Report and Gramophone Concert. 6.0, Gramophone Concert. 6.45, News. 7.0, Val Vouden. Entertainer. 7.15, Gaelic Talk. 7.30, Time Signal. 7.31, Concert by the Station Orchestra. 8.0, Flute Solos by M. Ahearn. 8.10, Pianoforte Solos by Violet Mackinnon. 8.25, The Station Orchestra. 8.40, Cello Recital by Madeline Monier. 9.0, Mezzo-Soprano Solos by Elizabeth Downey. 9.15, Cello Recital (cont'd.). 9.30 to 10.30, Programme by the I.B.C. (Ireland), Ltd. 9.30, Light Music; Madriid (Rotter); Valse Caprice (Rubinstein); After the Ball (Harris); Pierrette's Wedding (Jordan); Yip-I-addy-I-ay (Flynn); Violin Solo: Valse bluette (Drigo); Selection from The Maid of the Mountains (Fraser-Simson). 10.0, Concert arranged by the International Broadcasting Company (Ireland), Ltd.: Dance Music; Learn to Croon; Stay out of my Dreams; Hold me; Racing Commentary; I cover the Waterfront; Really Mine; My Moonlight Madonna; Mississippi Basin. 10.30, I.B.C. Good-night Melody, followed by News and Weather. 10.40, Accordion Solos by Terry Lane. 10.50, Pipe Solos by Liam Andrews. 11.0 (approx.). Close Down.

### BARCELONA

EAJ1, 858 kc/s, 349.6 metres; 8 kW.—7.0 p.m., Request Gramophone Music. In the interval at 7.30, Exchange. 8.0, Gramophone Music. 8.15, Anti-War Talk, followed by News. 9.0, Chimes, Weather, Exchange and Market Prices. 9.5, Educational Programme. 9.35, Concert by the Radio Orchestra: March (Freitag); Schatzwalzer (Joh. Strauss); Minuet (Torandell); Caprice viennois (Kreisler); Piece for Violin (Cols); A Song of Autumn (Elgar); Gavotte (Hummel). 10.0, Two Plays (Apeles Mestres): (a) La Sirena. (b) La Barca dels alfgits. In the interval at 11.0, News. 12 Midnight (approx.). Close Down.

### BARI

1,112 kc/s, 269.8 metres; 20 kW.—3.30 p.m., Programme for Children. 3.55 to 7.0, See Rome. 7.0, News in Albanian. 7.15 till Close Down. See Rome.

BASLE.—See Schweizerischer Landessender.

### BELGRADE

698 kc/s, 429.7 metres; 2.8 kW.—6.0 p.m., Talk. 6.30, Violin Recital. 7.10, Variety Concert. 9.15, Time and News. 9.30 (approx.), Relay of Foreign Stations.

### BERLIN

DEUTSCHLANDSENDER (Reichssender), 183.5 kc/s, 1,635 metres; 60 kW.—1.0 p.m., Gramophone Concert of Operetta Music. 2.0, Handwork Programme for Children. 2.30, Weather and Exchange. 2.45, Talk: The History of Flying. 3.0, See Heilsberg. 4.0, Sports Notes. 4.20, Concert by Robert Gaden and his Orchestra. 5.0, Poems. 5.5, Small Advertisements—Great Results—Humorous Scene with Music. 5.45, Chimes from Breslau Cathedral. 5.50, Weather and News. 6.0, Transmission for all German Stations, relayed from Hamburg. 7.0, To-day's Motto. 7.10, See Breslau. 9.0, News and Weather. 9.30, Talk: Winter Sport Competitions for 1934. 9.45, Weather. 10.0, See Langenberg. 11.0, Dance Music. 11.30 (approx.). Close Down.

### BERLIN

FUNKSTUNDE, 716 kc/s, 419 metres; 1.5 kW. Relayed by Zeesen, DJC, DJA, DJD, DJB, and DJE.—3.0 p.m., See Heilsberg. 4.0, Concert of Chamber Music: Pianoforte Trio in G (Haydn); Three Songs (Schubert): (a) Dem Unendlichen, (b) Suleika. (c) Wohin; Andante un poco mosso from the Pianoforte Trio in B flat. Op. 99 (Schubert); Three Songs (Schumann): (a) Waldesgespräch, (b) Der Nussbaum, (c) Sonnenschein; Quartet for Flute, Violin, Viola, and Cello (Mozart). 5.0, Lecture Recital; Discussion on Italian and German Opera by an Italian Music Critic and Nina Afri; Recital of Italian and German Arias by Lotte Schönauer and Garavello. 6.0, Transmission for all German Stations, relayed from Hamburg. 7.5, Concert by the Station Orchestra, conducted by Helmuth Theifelder: Soloists, Getrud Baumann (Soprano) and Herbert Ernst Groh (Tenor): Prelude to Act II of Ingwilde (Schillings); Soprano Aria from Undine (Lortzing); Three Pieces for Orchestra: Capriccio, Gavotte, and Tarantella, Op. 87 (Klugardt); Tenor Aria, Trayer from Alessandro Stradella (Flotow); Neapolitanischer Mandolinspieler, Op. 86 (Reinecke); Duet from The Barber of Bagdad (Cornelius); Overture, The Italian Girl in Algiers (Rossini); Tenor Aria from The

Barber of Seville (Rossini); Intermezzo from L'Amico Fritz (Mascagni); Flower Aria from Carmen (Bizet); Entr'acte from Carmen (Bizet); Two Tenor Arias from Tosca (Puccini); Extracte and Duet from Madame Butterfly (Puccini); Overture, The Force of Destiny (Verdi). 9.0, Weather and News. 9.15 (approx.), Dance Music by the Berlin Dance Band, relayed from the Delphi Palast. 12 Midnight (approx.). Close Down.

BERNE.—See Schweizerischer Landessender.

BEROMUNSTER.—See Schweizerischer Landessender.

BODEN.—See Stockholm.

BODO.—See Oslo.

### BORDEAUX-LAFAYETTE

986 kc/s, 304 metres; 13 kW.—7.0 p.m., Radio Journal. 7.55, Sports Talk. 8.0, News, Racing Results and Market Prices. 8.5, English Lesson. 8.20, News. 8.30, Martha—Opera (Flotow), relayed from Paris (Ecole Supérieure), 671 kc/s, 447.1 metres.

### BRATISLAVA

1,073 kc/s, 279.5 metres; 14 kW.—5.30 p.m., Gramophone Music. 5.45, Topical Talk. 5.55, Hints for Housewives. 6.0, See Prague. 6.25, Violin Recital of Norwegian Music by Henri Marteau: Sonata for Violin and Pianoforte (Johansen); Sanctus Dolores (Sinding). 7.15, A Radio Play. 7.40, Variety Programme: Part I, Potpourri of Popular Music (Silving), by the Station Orchestra, conducted by Dyk; Part II, Humorous Reading; Part III, The Sinner, Operetta in One Act (Peecke). 9.0, See Prague. 10.30 (approx.). Close Down.

BREMEN.—See Hamburg.

### BRESLAU

923 kc/s, 325 metres; 60 kW. Relayed by Giewitz, 1,185 kc/s, 253.1 metres.—1.10 p.m., Gramophone Music. 1.40, Programme arranged by the Post Office, with Gramophone Records. 2.0, Agricultural Prices. 2.35, Programme Announcements for the Coming Week. 2.45, Film Review. 3.0, Concert by the Eduard Andreozzi Orchestra, relayed from the Vier Jahreszeiten Café. 4.35, Talk: The Next Tasks of Science. 5.0, A Discussion between a German and an Italian Boy. 5.20, Programme to be announced. 5.45, Programme Announcements. 6.0, Transmission for all German Stations, relayed from Hamburg. 7.0, News. 7.10, Ein Waizer muss es sein—Musical Play about Johann Strauss and Joseph Lanner (Rolf Herbert Kunze). 9.0, Time and News. 9.30, Dance Music, relayed from Berlin (Funkstunde). 12 Midnight (approx.). Close Down.

### BRNO

878 kc/s, 342 metres; 35 kW.—5.25 p.m., German Transmission: News and Song Recital by Lia Kroupa (Soprano) and Anni Balzer (Contralto). 6.0, See Prague. 6.25, Brass Band Concert. 7.15, Concert of Old Chamber Music. 7.40, See Bratislava. 9.0, See Prague. 10.30 (approx.). Close Down.

### BRUSSELS (No. 1)

I.N.R., 589 kc/s, 509.2 metres; 15 kW.—12 Noon, Concert by the Station Orchestra, conducted by Pierre Leemans: Overture, The Barber of Seville (Rossini); Suite, At the Circus (Armandola); Liebestraum (Liszt); Selection from Samson and Delilah (Saint-Saëns); Violin Solo: Polonaise (d'Agreves); Ballet Music from Herodiade (Massenet); Dances from Tom Jones (German). 1.0 p.m., Le Journal Parlé. 1.10, Concert by the Primas Sylva Orchestra: Rakoczy March; Waltz, Mannequin (Montagne); Selection from The Merry Widow (Lehar); Czardas from Mariska (Lehar); Waltz, Neu Wien (Joh. Strauss); March (Ertl); Parlez-moi d'amour (Lenoir); Romanian Song and Dance (Sylva); Two Guitars (arr. Salabert); Livonia (Barch); March (Fueck). 4.45, Talk: The Protection of Birds in Winter. 5.0, Concert by the Radio Orchestra, conducted by Walpot. Soloist: Lombard (Vibraphone). Italian March (Sellenick); Potpourri of Viennese Waltzes (Gillon); Overture, The Secret Marriage (Cimarosa); La Lettre à Manon (Gille); Mendelssohn Potpourri (arr. Urbach); Vibraphone Solo: Where my Caravan has Rested (Lohr); Italian Caprice (Tchaikovsky). 6.0, Talk on Bull-lighting. 6.15, Gramophone Music. 6.30, Cello Recital by Pitsch: Sonata in F (Porpora); Elegiac Song (Scharrès); Improvisation on two Irish Airs (Hahn); Symphonic Variations (Boellmann). 7.5, Gramophone Records: Selection from La Serva padrona (Pergolesi); Symphonic Variations (Franck). 7.30, Le Journal Parlé. 8.0, Concert by the Radio Orchestra, conducted by Walpot. Soloist: Mlle. Duchateau (Songs): Potpourri of Soldiers Songs (Salabert); Overture, Poet and Peasant (Suppé);

Selection from Rose-Marie (Friml); Songs; Polka-Fantasia for Clarinets, La Chanson des Nids (Buot). 8.45, Talk: The Belgian Author, Edward Ewbank, with Readings from his Works. 9.0, Concert (cont'd.): Waltz Potpourri, No. 2 (Robrecht); Selection from Viktoria and Her Hussar (Abraham); In the Temple of the Bells (Yoshitomo); Songs; Hungarian Rhapsody No. 2 (Liszt); Suite de Ballet (Popy). 10.0, Le Journal Parlé. 10.10, Dance Music by Robert de Kers and his Cabaret Kings, relayed from the Century Hotel, Antwerp.

### BRUSSELS (No. 2)

N.I.R., 888 kc/s, 337.8 metres; 15 kW. Programme in Flemish.—12 Noon, Concert by Primas Sylva and his Orchestra. 1.0 p.m., Le Journal Parlé. 1.10, Concert by the Station Orchestra, conducted by Pierre Leemans. 5.0, Concert by Robert de Kers and his Cabaret Kings, relayed from the Century Hotel, Antwerp. 6.0, Allegro con brio and Theme with Variations from the Sonata in D, Op. 12, No. 1 (Beethoven), on Gramophone Records. 6.15, Talk: Flemish Literature as seen by a Dutchman. 6.30, Concert by the Small Station Orchestra, conducted by Leemans: Overture, Cigale et Mouton (Casadesu); Petite Suite (Busser); Barcarolle, Sur l'étang bleu (Gaillard); Selection from Adriana Lecouvreur (Gilda); Ariette for Cello (Martini); Selection from Fleur de thé (Leococq); Vision (Drhla); Waltz, Sphinx (Popy); Potpourri, Frühling im Wienerwald (Ascher). 7.30, Agricultural report. 8.0, La Traviata—Opera (Verdi), relayed from the Royal Opera House, Antwerp. In the intervals, Recitations, Gramophone Music, and Journal Parlé.

### BUCHAREST

761 kc/s, 394 metres; 12 kW.—4.0 p.m., Dance Music by the George Korologos Jazz Band. In the interval at 5.0, Radio Journal. 6.0, Educational Talk. 6.20, Gramophone Music. 6.45, Talk. 7.0, String Quartet (Chausson). 7.30, Answers to Correspondence. 7.45, Song Recital by Olga Hoch. 8.15, Musical Saw Solos by Galperin; The Lark (Glinka); Berceuse (Godard); Melody (Hartig); Romance (Leon). 8.45, Radio Journal. 9.0, Romanian Music by the Station Orchestra.

### BUDAPEST

545 kc/s, 550.5 metres; 18.5 kW.—Also relayed on 840 metres from 7.0 p.m. till Close Down.—4.30 p.m., Recital of Hungarian Folk Songs by Josef Cselenyi, with Cigány Music Accompaniment. 5.30, Talk. 6.0, Concert by the Losonczy Schweitzer Orchestra. Overture, Norma (Bellini). Song: Apple Blossom (Losonczy Schweitzer); Potpourri, Puding (Morena). 6.30, The Letter Box. 7.0, Opening Ceremony of the New Budapest High Power Broadcasting Station.

CASSEL.—See Frankfurt.

### COPENHAGEN

1,067 kc/s, 281 metres; 0.75 kW. Relayed by Kalundborg, 260 kc/s, 1,153.8 metres, and Skamiebaek, OXY, 49.4 metres.—11.0 a.m., Time Signal and Chimes from the Town Hall. 11.15, Broadcast for Schools. 11.45, Concert by the Bendix String Ensemble, relayed from the Wivex Restaurant. 1.0 p.m., Interval. 2.0, Concert by the Louis Prell Instrumental Ensemble. Two Pieces (Myddleton): (a) Fatsy, (b) The Swanky Drum Major; Serenata amorosa (Bridgewater); Southology (Sander); Suite of Viennese Waltzes (Gillon); Selection from Good News (Sylva, Brown and Henderson); Nixengefüster (Heykens); Gallop (Krüger); Dolly Dimples (Alter); Intermezzo, Sag mir, wer du bist (Grothe); Negro Rhapsody (Johnson); Flower Song (Schröder); Mignonette (Poeyzy); Waltz (Moe); Intermezzo (Demaret); Two-Step, Seville (Alfonso). In an interval at 2.45, Readings from the Jutland Writer, Kjerup. 4.0, Gramophone Concert of Variety Music. 4.30, Exchange and Fish Market Prices. 4.45, Talk: The Development of the Waltz. 5.15, French Lesson. 5.45, Weather. 5.54, Announcements. 6.0, News. 6.15, Time Signal. 6.30, Talk on Music. 7.0, Time Signal from the Town Hall. 7.1, Concert of Seventeenth-Century German Music, by the Radio Chamber Orchestra, conducted by Fritz Mahler. Concerto grosso No. 2 in A (Muffat); Suite, Tafelmusik (Telemann). 7.25, Talk and Reading from Holberg's Epistles. 8.0 to 10.0, Variety Programme. 8.0, Johann Strauss Concert by the Radio Orchestra, conducted by Fritz Mahler. Waltz, Künstlerleben; Polka, Tritsch-Tratsch; Persian March; Waltz, O schöne Mai; Overture, The Queen's Kerchief. 8.30, Song Recital by Ely Fischer Kjerulf. 8.50, Banjo Solos, by Edwin Taaning. 9.5, News. 9.20, Concert of Operetta Overtures by the Radio

Orchestra, conducted by Fritz Mahler. Overtures to Fatinitza (Suppé), Madame Favart (Offenbach), The Mikado (Sullivan), and A Waltz Dream (O. Straus). 9.45, Improvisations by Axel Boesen. 10.5, Dance Music by the Otto Lington Band, relayed from the Ritz Restaurant. In an interval at 11.0, Time Signal and Chimes from the Town Hall. 11.15 (approx.), Close Down.

CORK.—See Athlone.

DANZIG.—See Heilsberg.

DRESDEN.—See Leipzig.

### FECAMP

1,328 kc/s, 225.9 metres; 10 kW.—11.0 a.m. to 12 Noon, Programme in English by the I.B.C. 11.0, Happy Hour. Part I: Orchestral Concert. Signature Tune; March from La Czarine (Ganne); Song, How deep is the Ocean? (Berlin); Velea Medley (Varney); Pianoforte Solo: Selection from Waltz Time (Strauss); Little Yvonne (Schwartz); Selection from Give me a Ring (Broones); Song: Black Moonlight (Coslow); Pride of the Wolfines (Souza). Part 2: Dance Music. Dear Stranger; Pettin' in the Park; Love in the Moonlight; I've got you on my Mind; A Couple of Pals; A Couple of Fools in love; Symphony of the Breeze; One Horse Town. 12 Noon, French Programme. 3.30 to 6.0 p.m., Programme in English by the I.B.C. 3.30, Accordion Band Music; The Best of the Bunch (Alexander); Valse la Reine (Alexander); Dinah (Lewis); Melody (Alexander); Cocktails (Cuevler); Milano (le Clerc); By the Shimmering Twilight Sea (Williams); Accordion Joe (Wim-brow). 4.0, Dance Music; Signature Tune: The Bells of Normandy; Egypt; Who's afraid of the Big Bad Wolf?; Ah, but it's love; My Moonlight, Madonna; Well done, Gordon; A couple of Fools in love; Si, Si; Oh, Johanna; Signature Tune: The Bells of Normandy. 4.30, The I.B.C. Nursery Corner. Birthday Greetings; Trumpets. 4.40, Concert of Light Music for Tunbridge Wells and Isle of Thanet Listeners: Trumpets; Signature Tune: The Night by the Sea; Waltz from The Gipsy Princess (Kálmán); The Coon among the Chickens (Ives); Dainty Lady (Leo Peter); Second Serenade (Heykens); Waltz Medley (arr. Simpkin); Whispering Flowers Idyll (von Blon); In Vienna One Night (Bordin); Smilin' through (Penn); Play of Butterflies (Heykens); Selection from Give me a Ring (Broones). 5.20, Concert of American Songs: For Dover and Folkestone Listeners. Trumpets; That Lindy Hop (Kazag); Fortunes Galore; Hallelujah, I'm a Bum (McClintock); The Whistler and his Dog (Pryor); Smoky Mountain Bill (Robinson); She's Everybody's Sweetheart now (Hargreaves); Selection from He wanted Adventure (Waller); In a Year, in a Day (Heymann); Thanks (Coslow); Heaven will protect an Honest Girl (Weston); Signature Tune. 11.30, Concert arranged by the International Broadcasting Company (Ireland), Ltd. Signature Tune: Come back to Erin; Pan and the Wood Gobins (Rathke); Rose mousse (Bosc); Selection from The Arabian Nights (Strauss); Minuet (Mozart); Pizzicato from Sylvia (Delibes); Lazy Pete (Werner); One Alone from The Desert Song (Romberg); The Fairies' Gavotte (Kohn); Signature Tune. 12.5 a.m. (Monday), Late News Bulletin in English. 12.10 (approx.), I.B.C. Club Concert for Llanganmarch Wells Listeners: Signature Tune: The Chum Song; Smoke Rings (Gifford); Lazybones (Mercer); Cornflowers and Poppies (Waldteufel); Gipsy sing for me (Pola); Everyone loves my Marguerite (Woods); You're an Old Smoothie (Whiting); Selection from Dinner at Eight (Fields); Tick, Tock (Vienna); The Last Round up (Hill); Rosa Mia (Fisher); A Couple of Pals (Gilbert); Love in the Moonlight (Lewis); Don't blame me (Fields); Signature Tune. 1.0, Dance Music: Signature Tune: The Bells of Normandy; Trouble in Paradise; Dear Stranger; The Wedding of Mr. Mickey Mouse; Sweet Dreams, Pretty Lady; Under a Blanket of Blue; At the Old Pig and Whistle; Aromas Mendocinas; I've told Every little Star; Wear a Great Big Smile; Dance, Pretty Lady; Little Nell; Tonight; Symphony of the Breeze; Moths around the Candle Flame; If you'll say Yes, cherie (Noble); Ninon (Moretti); Signature Tune: The Bells of Normandy. 2.0, I.B.C. Goodnight Melody and Close Down.

FLENSBURG.—See Hamburg.

FLORENCE.—See Turin.

### FRANKFURT

1,157 kc/s, 259.3 metres; 17 kW. Relayed by Cassel and Trier, 1,157 kc/s, 259.3 metres.—12.15 p.m., Time and News. 12.25, Local News and Weather. 12.35 to 2.30, See Stuttgart. 2.30, Weather. 2.40, Time and Economic Notes. 3.0, See Langenberg. 5.0, Talk: Frontier Problems. 5.20, Review of the Week. 5.35, Surprise Programme. 5.50, Weather and News. 6.0, Transmission for all German Stations, relayed from Hamburg.

DEC. 2nd **SATURDAY** continued

7.0, Topical Talk. 7.10, Bunter Abend in Aid of the Winter Relief Fund, relayed from the Funkhaus. 9.0, Time and News. 9.20, See Stuttgart. 9.30, News. 9.45, Concert of Light Music. 10.0 till Close Down, See Langenberg. 12 Midnight, Close Down.

**FREDRIKSTAD.**—See Oslo.

**FREIBURG.**—See Stuttgart.

**GENEVA.**—See Radio-Suisse Romande.

**GENOA.**—See Turin.

**GLEIWITZ.**—See Breslau.

**GÖTEBORG.**—See Stockholm.

**GRAZ.**—See Vienna.

**HAMAR.**—See Oslo.

**HAMBURG**

806 kc/s, 372 metres; 1.5 kW. Relayed by Bremen, 1,112 kc/s, 269.8 metres; Flensburg and Hanover, 1,319 kc/s, 227.4 metres; and Kiel, 1,292 kc/s, 232.2 metres.—3.0 p.m., See Heilsberg. 4.0, See Berlin (Funkstunde). 5.0, Werner Beunelburg reads from his own works. 5.25, Military Programme. 5.40, Radio Review. 5.50, Weather. 6.0, Transmission for all German Stations: Concert by the Hamburg Philharmonic Orchestra, conducted by José Eibenschütz: Jagd-Ouvertüre (Künneke); Dance Suite (Hofers); Tarantella, Venezia e Napoli (Liszt); Heiteres Spiel (Blumer); North German Peasant Dances (Thalil); Waltz, Tales from the Vienna Woods (Joh. Strauss). 7.5 till Close Down, See Berlin (Funkstunde). In an interval at 9.0, Time and News. 12 Midnight (approx.). Close Down.

**HANOVER.**—See Hamburg.

**HEILSBURG**

1,085 kc/s, 276.5 metres; 60 kW. Relayed by Danzig, 671 kc/s, 447.1 metres.—12.5 p.m., Gramophone Concert of Variety Music. In the intervals at 12.20 and 1.0, News. 1.30, Programme arranged by the Post Office with Gramophone Records. 2.0, Agricultural Prices and Exchange. 2.30, Programme for Girls. 3.0 (from Danzig), Concert by the Danzig Municipal Theatre Orchestra, conducted by Ernst Kallipke: Overture, Euryanthe (Weber); Soirées de Vienne (Schubert); Meditation from Thais (Massenet); Pizzicato Polka from Ritter Pasman (Joh. Strauss); Italian Serenade (Hugo Wolf); Selection from Die toten Augen (d'Albert); Dance Intermezzo (Sibelius); Waltz, Amoretantänze (Gungl); Norwegian Bridal Procession (Grieg); Hungarian Dances Nos. 1 and 2 (Brahms); Overture, Berberscher der Geister (Weber). In the interval at 4.0 (approx.), Traffic Report. 4.45, Lieder der neuen Front (Richard Trunk), to words by Baldur van Schirach, by the Tilsit Male Voice Choir, relayed from Tilsit. 5.5, Programme Announcements. 5.15, Agricultural Prices. 5.25, East Prussian Review of the Week. 5.50, Weather. 6.0, Transmission for all German Stations, relayed from Hamburg. 7.0, News. 7.10, Langenarok, Radio Play (Meyer-Diwert). 8.30, Piano-forte Quartet, Op. 5 in E Flat (Louis Ferdinand, Prince of Prussia), by the Königsberg Chamber Music Society. 9.0, News. 9.15 (approx.), Dance Music on Gramophone Records. 11.30, (approx.), Close Down.

**HILVERSUM**

1,013 kc/s, 296 metres; 7 kW. up to 5.40 p.m. and 20 kW. from 5.40 p.m. Programme of the Workers' Radio Society (V.A.R.A.).—11.55 a.m., Concert by the Small V.A.R.A. Orchestra conducted by de Groot: Turkish March (Mozart); Je l'aime (Waldteufel); Chinese Flirtation (Charmon); Wedding Day on Troldhaugen (Grieg); Pastorale (Widor); Illusion (Henschel); La cinquantaine (Gabriel Marie); Hearts and Flowers (Czibulka); Two Guitars (Horlick); Laura (Millöcker). 12.40 p.m., Orchestral Concert. 1.40, Interval. 1.55, Gramophone Music. 2.40, Light Music by the V.A.R.A. Mandoline Orchestra. 3.10, Talk. 3.30, Orchestral Concert conducted by Horst: The Marchés (de l'Isle-Rennes); Selection from Schön is die Welt (Lehár); Marionettes (Landschulz); The Birthday of Mr. Mickey Mouse (Meyers); Melody; Selection from The Vagabond King (Friml). 3.55, Gramophone Music. 4.10, Concert (contd.). 4.40, Talk on the Cinema. 5.0, Harpichord and Violin Recital by Gertrud Wertheim and de Klijn: Sonata in A (Bach); Gramophone Records: Sarrabande and Allegretto (Senallé); Gavotte (Arne); Allegro (Piooco). 5.40, Talk on Literature. 6.0, Organ Recital by de Jong, with Gramophone Interludes. 6.40, Programme to be announced. 7.40, 5 O S Messages, News and V.A.R.A. Notes. 7.55, Concert by the V.A.R.A. Orchestra, conducted by de Groot: Selection from Hunyadi Laszlo (Ferencz); Die Werber (Lauer); Cossack Dance (Dargomyski); Ballet Music from Faust (Gounod). 8.40, Talk. 8.50, Songs to the Lute, by Mouljn. 9.10, Concert (contd.). Im D-Zug (Blon); In Vlaanderen Vlaamische Kermis (Blockx); Ça c'est Paris (Padilla); On the Riviera (Dauiderv); Tyrolese Songs and Dances (Petras); Grüss mir mein Wien (Kalmán); Constantinople (Carlton); On the Bosphorus (Lincke); In a Turkish Bazaar (Dreyer); Melody (Gray); We gaan naar Zandvoort (Davids); Hallo,

hier Hilversum (de Groot). 9.55, Gramophone Records. 10.10, Concert (contd.): Entry March of the Gladiators (Frick); Pikantieren (Lehár); In a Clock Store (Orth); Serenade (Heykens); Waltz: Potpourri (Bohrecht); Marionetten Groteske (Dreyer); The Frog's Wedding (Beil); Melody (Ciere). 10.55, Recitation. 11.0, Organ Recital by Steyn. 11.40 (approx.), Close Down.

**HORBY.**—See Stockholm.

**HUIZEN**

160 kc/s, 1,875 metres; 7 kW. until 3.40 p.m. Transmitted from Kootwijk on 50 kW. from 3.40 p.m. Programme of the Catholic Radio Society (K.R.O.). 11.55 a.m., Concert by the K.R.O. Sextet, conducted by Lustenhopper: Spanish March (Grit); Canzone di Maggio (de Michel) Der Himmel voller Geigen (Zieherer); Melody (Ganghertger); Russian Fantasia (Stabel); Improvis. (Schubert); Gramophone Records, Tempo. Tempo (Schootenmeyer); Darling (Lincke); Selection from Lilac Time (Schubert-Berte); Une Fête au Trianon (Popy); Was die Donau erzählt (Morena); Finale. 1.40, Programme for Young People. 2.10, Programme for Children. 3.40, H.I.R.O. (Hebrew Radio Society) Programme. 4.40, Writing Lesson. 5.10, Esperanto Notes. 5.25, Gramophone Music. 5.35, Technical Talk. 5.50, Gramophone Music. 6.0 Press Review. 6.25 Concert by K.R.O. Boys conducted by Lustenhopper. 6.40, Police Notes. 6.55, Medical Talk. 7.15, Concert (contd.). 7.40, Gramophone Music. 8.0, Songs by De Bossche Revellers. 8.10, News. 8.15, Concert by the K.R.O. Orchestra, conducted by van 't Woud: Festjubel-marsch (Blanckenburg); Die Glocken von Prag (Frick); Extase (Ganne); Her first Dance (Heykens); Waltz, Espana (Waldteufel). 8.40, Recitations. 8.55, Songs by De Bossche Revellers (contd.). 9.5, Concert (contd.): Wien bleibt Wien (Selrammel); Dance of the Marionettes (Gilbert); Melody (Armandola); Selection from The Love Parade (Schertzinger). 9.30, Gramophone Music. 10.0, Songs by De Bossche Revellers (contd.). 10.30, News. 10.35, Concert by the K.R.O. Orchestra (contd.): American Patrol (Meacham); Les deux Rossignols (Rol); Berceuse de Jocelyn (Godard); The Wedding of the Rose (Jessel); March, Alte Kamaraden (Teike). 10.40, Gramophone Music. 10.40 (approx.), Close Down.

**INNSBRUCK.**—See Vienna.

**JUAN LES PINS**

**NICE,** 1,205 kc/s, 249 metres; 0.8 kW.—8.0 p.m., Amusement Guide, Exchange and News. 8.10, Cinema Review. 8.25, Concert. 9.0 (in an interval), News and Weather.

**KALUNDBORG.**—See Copenhagen.

**KIEL.**—See Hamburg.

**KLAGENFURT.**—See Vienna.

**KOSICE.**—See Prague.

**LANGENBERG**

635 kc/s, 473 metres; 60 kW.—12.15 p.m., See Frankfurt. 12.25, News. 12.35 to 2.30, See Stuttgart. 2.30, Economic Notes. 2.45, Reading (Hebel). 3.0, Variety Concert. Part I: Gramophone Music. Part II: Concert by the Station Chamber Choir, conducted by Josef Breuer. Soloists: Maiga Bäuml (Guitar) and Eibert Grape and Hans Haas (Pianoforte). 5.0 to 5.35, See Frankfurt. 5.35, Fiddle Solos. 5.50, Announcements. 6.0, Transmission for all German Stations, relayed from Hamburg. 7.0, See Frankfurt. 7.10, Concert, relayed from Emmerich. Part I: Künneke Music by the Station Orchestra, conducted by the Composer. Overture, The Ace of Hearts; Dance Suite. Part II: Gramophone Music. Part III: Musik by the Station Orchestra, conducted by Kühn. Soloist: Kläre Hansen (Soprano). Viennese Waltz (Wagenaar); Songs for Soprano and Orchestra (R. Strauss): (a) Das Rosenband, (b) Ständchen; Waltz from Der Rosenkavalier (R. Strauss); Polonaise in E (Liszt); Perpetuum mobile (Joh. Strauss); Radetzky March (Joh. Strauss). 9.0, See Frankfurt. 9.20, See Stuttgart. 9.30, News and Weather. 9.45, Light Music on Gramophone Records. 10.0, Report on the Six Days' Racing. 10.15, Bunter Abend. A Dance Band and the Fröhliche Fünf. Conductor: Curt Baumgarten. 11.0, Serenade on Gramophone Records. 1.0 a.m. (Sunday), Close Down.

**LAUSANNE.**—See Radio-Suisse Romande.

**LEIPZIG**

770 kc/s, 389.6 metres; 120 kW. Relayed by Dresden, 941 kc/s, 319 metres.—12.30 (from Dresden), Concert by Pepi Stoss and his Viennese Schrammel Trio. March, Grüss Gott Wien (Kerker); Waltz, Süsse Mädel (Reinhardt); Amatische Zauberer (Siede); Johann Strauss Waltz Potpourri (Weinstahl); Selection from The Bird Fancier (Zeller); Song, Ich war zu Heidelberg

Student (Lob); Waltz, Fideles Wien (Komzak); Ferd-Marsch (Wächter). 1.15, News. 1.30, Programme for Children. 2.10, Agricultural Notes. 2.25, Talk on Economics. 2.40, Economic Notes and Weather. 3.0, Concert Relay. 4.30, Review of Periodicals. 4.50, Reading (Ferdinand Thürmer). 5.20, A Modern Dictionary. 5.45, Today's News. 6.0, Transmission for all German Stations, relayed from Hamburg. 7.0, See Breslau. 9.0, News. 10.0, See Munich. 11.0 (approx.), Close Down.

**LINZ.**—See Vienna.

**LJUBLJANA**

522 kc/s, 574.7 metres. 7 kW.—6.0 p.m., Talk on Philosophy. 6.30, Talk: Foreign Affairs. 7.0, Orchestral Concert. 8.0, Vocal Quartets. 8.30, Weather and News. 8.50, Dance Music.

**LUXEMBOURG**

252 kc/s, 1,191 metres; 200 kW.—French Evening. 7.0 p.m., The Fantastic Symphony (Berlioz), on Gramophone Records. 7.30, Trio No. 2 (Beethoven), by René Delporte (Pianoforte), Ernst Eichel (Violin), and Leon van Eekhout (Cello). 7.55, Cinema Review. 8.5, Concert of French Music by the Station Orchestra, conducted by Henri Pensis. Overture, Mignon (Thomas); Clair de lune (Koecklin); Suite of Dances (Pierné). 8.30, Review of Economics. 8.35, Concert (contd.). Ballet Suite, La Source (Delibes). 8.50, News in French. 9.0, Radio Luxembourg Musical Medley—International Concert by the Station Orchestra, conducted by Henri Pensis, and Soloists. 9.50, News in German. 10.0, Gramophone Concert. Overture, Mirella (Gounod); Selection from Il Trovatore (Verdi); Selection from Samson and Delilah (Saint-Saëns); Selection from Louise (Charpentier); Selection from Gipsy Love (Lehár); Selection from The Grisha (Jones); Selection from Grande Reine (Genelar); Selection from Tip Toes (Gershwin); Selection from Sunny (Kern). 10.50, Dance Music.

**LWOW**

788 kc/s, 381 metres; 16 kW.—6.0 p.m., History Talk. 6.12, Announcements. 6.25, See Warsaw. 6.55, Programme Announcements. 7.0, See Warsaw. 9.15, Concert of Light Music by a Mandoline Orchestra. 10.0, See Warsaw. 11.0 (approx.), Close Down.

**LYONS**

**LA DOUA,** 644 kc/s, 465.8 metres; 3 kW.—7.30 p.m., Radio Gazette for Lyons and the South East. 8.30, Operetta Music, relayed from Paris (Ecole Supérieure), 671 kc/s, 447.1 metres. After the Relay: News Bulletin.

**MADRID**

**ARANJUEZ (EAQ),** 10,000 kc/s, 30 metres; 20 kW.—6.0 to 8.0 p.m., Programme for Listeners in the Canary Islands, Guinea and Europe. 6.0, Popular Concert. 7.15, Talk. 7.30, Light Music. 8.0 to 10.30, Interval. 10.30, Concert of Popular Music. 10.45, Radio Chronicle. 11.0, Concert Versions of La Generala—Musical Comedy (Vives), and Jotas aragonesas (Navarro). 11.45, Light Music. 12 Midnight till Close Down. I.B.C. Concert of Dance Music: Say it with Music (Moll); Mama Inez (Grenet); They didn't believe me (Kern); Love's Old Sweet Song (Molloy); Oh, Johanna (Lawrence); It's the Talk of the Town (Sykes); The Wedding of Mr. Mickey Mouse (Pola); The Last Round up (Hill). 12.30 a.m. (Sunday), I.B.C. Good-night Melody and Close Down.

**MADRID**

**EAJ7,** 707 kc/s, 424.3 metres; 2 kW.—7.0 p.m., Chimes, Exchange, Topical Talk, Talk, Dance Music and Talk on Hygiene. 8.15, Radio Journal. 8.30 to 9.15, Interval. 9.15, English Lesson. 9.30, Chimes, Time and Radio Journal. 9.45 (approx.), Music Competition: Part I—Violin Recital by Luis Anton; The Devil's Sonata (Tartini-Kremler); First Movement of the Concerto No. 2 (Vieuxtemps); Spanish Suite (Nin-Kochansky); Divertissement (Pittaluga); Songs without Words (Hiller); Part II—Song Recital by Consuelo Obregon: Romance, Katiciska (Sorazabal); Variations (Proch); Madrigal (Villar); Allegro from La Sonnambula (Bellini); Song (Anli) Aria from Rigoletto (Verdi); Hindu Song (Rinsky-Korsakov); Romance, Marina (Arieta). 11.45, Radio Journal. 12 Midnight, Chimes and Close Down.

**MALMO.**—See Stockholm.

**MILAN.**—See Turin.

**MORAVSKA-OSTRAVA**

1,137 kc/s, 263.8 metres; 11 kW.—5.25 p.m., Concert of Russian Music by a Balalaika Orchestra, conducted by Ivan Cynuljansky. 6.0, See Prague. 6.25, Concert by the Station Orchestra, conducted by Musil: Overture, Isabella (Suppe); Waltz from The Bombon King (Provanzik); Selection

from The Land of Smiles (Lehár); Elegy and Krakowiak from Polenhut (Nedbal); Polka (Moor); Spanish Dance (Kinel). 7.15, See Prague. 7.40, See Bratislava. 9.0, See Prague. 10.30 (approx.), Close Down.

**MOSCOW**

**KOMINTERN,** 202.5 kc/s, 1,481 metres; 50 kW.—3.30 p.m., Educational Programme. 4.30, Red Army Programme. 5.30, Programme for Collective Farm Workers. 6.30, Talk: The Röntgen Rays. 7.0, Concert. 8.0, Programme in German. 8.55, Chimes from the Red Square. 9.5, Programme in French. 10.15, Programme in Spanish.

**MOTALA.**—See Stockholm.

**MUHLACKER.**—See Stuttgart.

**MUNICH**

563 kc/s, 533 metres; 1.5 kW. Relayed by Augsburg and Kaiserslautern, 536 kc/s, 560 metres; and Nürnberg, 1,256 kc/s, 239 metres.—3.30 p.m., Concert by the Small Station Orchestra, conducted by Karl List: Overture, Die Fledermaus (Joh. Strauss); The Skaters' Waltz (Waldteufel); Romantic Suite, Walpurgisnacht (Lüling); Serenade (Widor); Berceuse (Godard); Scherzo (d'Albert); Potpourri, From the Rhine to the Danube (Rhoda); March, Waidmanns Heil (Reckling). 4.45, Programme for Young People. 5.15, String Quartet (Pottgiesser), by the Strauhar String Quartet. 5.45, Wireless Notes. 6.0, Transmission for all German Stations, relayed from Hamburg. 7.0, See Breslau. 9.0, Time and News. 10.0, Serenade. 11.0 (approx.), Close Down.

**NAPLES.**—See Rome.

**NOTODDEN.**—See Oslo.

**OSLO**

277 kc/s, 1,083 metres; 60 kW. Relayed by Fredrikstad, 815 kc/s, 368.1 metres; Hamar, 522 kc/s, 574.7 metres; Notodden, 671 kc/s, 447.1 metres; Porsgrund, 662 kc/s, 453.1 metres; and Rjukan, 671 kc/s, 447.1 metres.—3.30 p.m., Gramophone Concert. 4.15, Programme for Children. 5.15, Norwegian Music by a Hardanger Fiddle Trio. 5.45, Talk on Economics. 6.0, Announcements, Weather and News. 6.30, Talk. 7.0, Time Signal. 7.1, Popular Concert by the Station Orchestra and Soloists. 8.40, Weather and News. 9.0, Topical Talk. 9.15, Songs to the Ukelele and Hawaiian Guitar, by Gerd and Otto Nielsen, relayed from Trøndelag. 9.45, Gramophone Music. 11.0 (approx.), Close Down.

**ÖSTERSUND.**—See Stockholm.

**PALERMO**

556 kc/s, 539.5 metres; 3 kW.—7.0 p.m., Dopolavoro Announcements, Tourist Talk, Agricultural Notes and Giornale Radio. 7.20, Gramophone Music. In the interval at 7.25, Sports Notes, Time and Announcements. 7.45, Casa mia, casa mia—Operetta in Three Acts (Pietri). In the interval, Book Review and Announcements. 10.0, Giornale Radio.

**PARIS**

**EIFFEL TOWER,** Call FLE, 207.5 kc/s, 1,445.7 metres; 13 kW. Time Signals (on 2,650 metres) at 9.26 a.m. and 10.26 p.m. (Preliminary and 6-dot Signals).—5.45 p.m., Le Journal Parlé. 7.15, Weather. 7.25, News. 7.30, Les châteaux en Espagne (Castles in Spain)—Comedy in Five Acts (d'Harleville). 9.0 (approx.), Close Down.

**PARIS**

**POSTE PARISIEN,** 914 kc/s, 328.2 metres; 60 kW.—7.0 p.m., Numerous Scenes on Gramophone Records. 7.15, Le Journal Parlé. 7.30, Waltz Music on Gramophone Records: Grande valse brillante (Chopin); Valse lente in A minor (Chopin); Valse, Op. 64, No. 2 (Chopin); Song Waltz (Vogel); The Blue Danube (Joh. Strauss). 7.50, Talk: The Event of the Week. 8.0, Theatre Review. 8.10, Interval. 8.30, Sponsored Programme. 9.0, Interval. 9.20, Jazz Music and Dance Music, conducted by Lucien Morawek. 11.30, News.

**PARIS**

**RADIO-PARIS,** Call CFR, 174 kc/s, 1,725 metres; 75 kW.—6.45 a.m., Physical Culture. 7.30, Weather and Physical Culture. 7.45, Gramophone Music. 8.0, Press Review and Weather. 9.30, Concert arranged by the Société des Concerts, relayed from the Conservatoire. 12 Noon, Gramophone Concert. Cordoba (Lozano-Salvador); Tyrolienne (Blangy); Fleur fanée (Legendre); In a Clock Store (Orth); Melody (Lindsay-Thielmer); Santica (Guida); S'aimez (Gabarcho); Ah! le beau rêve (Gauvain-Daris); Fête militaire (Sulvain); Pettillante (Marceau); Stances (Flegier); Un tango languoureux (Mateo-Decker); La Rose rouge, from Monsieur Beaucaire (Messenger); Petite Suite de Concert (Coleridge-Taylor); Des mots d'amour (Grouon); Selection from Madame Pompadour (Fall); March (Rhode); Le Carton de Wiert (Noury); Serenade, Il Bacio

DEC. 2nd **SATURDAY** continued

(Micheli); Singing in the Rain (Nacht-aero-Brown); Amia (Lincke); Magic Lantern (Godard); The Mill in the Black Forest (Eilenberg); Miroir du Desert (Magritte-Parès); Deilah (Nicholls); Selection from Le Prince Charmant (Parès-Van Parys); Manola (Liberaud); Chéri (Monte-Willite); Melody (Mahieux-Craven); The Wedding of the Painted Doll (Nacio-Herb-Brown); A Pamericame (Marceau). In the interval at 1.0, Exchange, News and Weather, and at 1.30, Exchange. 2.0, Relay of the Addresses from the Académie des Beaux-Arts. 3.0, Programme for Children. 3.45, Exchange and Market Prices. 6.20, Agricultural Report. 6.45, Gramophone Music. 7.0, Talk: Forgotten Inventors. 7.20, Gramophone Music. Ma Kosine (Nelly Laurent-Balet); Eternel Printemps (Popy); The Song of the Vagabond (Richmann); Jonjou (Fischer); J'ai deux amours (Scott); Adoration (Phillipon); Je connais une blonde (Goety-Sloane); Bandone (Maffia y Spina). 7.45, Review of the Latin Press. 8.0, Song Recital. In the intervals: News, Weather, Sports Notes, Review by Jean Rieux, Press Review and News.

**PITTSBURGH**

**KDKA**, 980 kc/s, 306 metres; 50 kW. Relayed on **WEXX** on 48.46 metres and 25.27 metres.—6.45 to 10.30 p.m., **New York** relay. 6.45, Football Game. 9.30, Dance Masters. 10.0, Casino Orchestra. 10.30, A Recre—Bill and Alex. 10.45, Orphan Annie, from **New York**. 11.0, News, Pat Haley. 11.15, Sports and Programme Preview. 11.30, Evening. 11.45, Programme to be announced. 12 **Midnight**, Happy Felton's Orchestra. 12.30 to 3.0 a.m. (**Sunday**), **New York** Relay. 12.30, Trio Romantic. 12.45, O'Leary's Irish Minstrels. 1.0, Waldorf Orchestra. 1.30, Sous les Ponts de Paris. 2.0, Jamboree. 3.0, Behind the Law.

**PORSGRUND**.—See Oslo.

**PRAGUE**

614 kc/s, 488.6 metres; 120 kW.—3.0 p.m., Concert of Light Music by Dvorsky and his Melody Boys. 3.50, Educational Talk for Young People. 4.15, Talk on Commerce. 4.25, Gramophone Records. 4.35, Czech Lesson for German Listeners. 4.50, Gramophone Records. 5.5, Agricultural Talk. 5.15, Talk for Workers. 5.25, News in German. 5.30, German Transmission: Musical Programme. 6.0, Time, News and Weather. 6.10, Talk. 6.25, See **Brno**. 7.15, Recital of Contemporary Music for Two Pianofortes, by Ervin Schulhoff and Letius; Sonata Op. 41 (Vojáček); Two Divertissements (Zelinka). 7.40, See **Bratislava**. 9.0, Time, News, Review of the Day and Sports Notes. 9.15, Dance Music by a Brass Band, a Vocal Quartet and Accordionists (Duets); March (Sykora) and Waltz (Behlik); Polka (Pehel); Tango (Tichy); March (Balling); Waltz (Kricka); Polka (Lahsky); Tango (Voldan); Potpourri (Bernhard); Waltz (Poncar); Polka (Czany); (Balling); March (Biskup). 10.30 (approx.), Close Down.

**RADIO-SUISSE ROMANDE**

**SOTTENS**, 743 kc/s, 403 metres; 25 kW; and **Geneva**, 400 kc/s, 749.9 metres.—6.0 to 6.15 a.m. (from **Lausanne**), Gymnastics. 11.28, Time Signal from Neuchâtel Observatory. 11.30, News, Weather and Sports Notes. 11.40 (from **Geneva**), Gramophone Music. 12 **Noon** (from **Geneva**), Financial News. 12.10 p.m. (from **Geneva**), Gramophone Concert. 1.0 to 2.58, Interval. 2.58, Time Signal from Neuchâtel Observatory. 3.0 (from **Lausanne**), Concert by the Small Radio Lausanne Orchestra, conducted by Moser. 3.45, Concert relayed from **Lugano**. 5.0 (from **Geneva**), Programme for Children. 5.20 (from **Geneva**), Talk for Young People: Notable Swiss Men. 5.40 (from **Geneva**), Film Review. 6.5 (from **Geneva**), Talk: Insurance against Accidents at Work. 6.30 (from **Geneva**), Weather and Announcements. 7.0 (from **Geneva**), Dance Rhythms. 7.10 (from **Geneva**), Variety Items by Ruy Blag. 7.25, Introductory Talk to the Following Transmission. 7.35, Concert by the Radio-Suisse Romande Orchestra, conducted by Ernest Ansermet. Soloist: Fernand Pollain (Cello); Extracts from Manfred (Schumann); Cello Concerto (Haydn); Rhapsody for Clarinet and Orchestra (Debussy); Suite for Cello and Orchestra, Pollainiana (Strong); Overture, The Mastersingers (Wagner). 8.30 (approx.), News and Weather. 9.0 (approx.), Talk: The Work of the League of Nations. 9.30 (from **Geneva**), Dance Music on Gramophone Records. 10.30 (approx.), Close Down.

**REYKJAVIK**

250 kc/s, 1,200 metres; 21 kW.—8.10 p.m., Weather. 8.20, Musical Programme and Announcements. 8.35, Programme to be announced. 9.0, Chimes. 9.2, Concert by the Radio Trio. 9.30, Reading. 10.0, News. 10.30, Choral Music on Gramophone Records, followed by Dance Music. 1.0 a.m. (**Sunday**), Close Down.

**RIGA**

571 kc/s, 525.3 metres; 15 kW.—6.5 p.m., Concert of Marches and Dances from Opera, conducted by Parups: Polonaise and Waltz

from Eugene Onegin (Tchaikovsky); Gavotte from Mignon (Thomas); Rigandon from Dardanus (Rameau); Waltz from Faust (Gounod); Ballet Music from Lakmé (Delibes); Persian Dances from Khovanstchina (Mussorgsky); Gopak from The Fair at Sorochinsk (Mussorgsky); March from Prince Igor (Borodin); March from Lohengrin (Wagner); Dance of the Shadows from Dinorah (Meyerbeer); March of the Toreadors from Carmen (Bizet); Waltz from Der Rosenkavalier (R. Strauss); March from Tannhäuser (Wagner). In the interval at 7.0, News. 8.0, Weather and News. 8.15, Choral Concert. 9.0, Dance Music. 10.0 (approx.), Close Down.

**RJUKAN**.—See Oslo.

**ROME**

**Call 1RO**, 680 kc/s, 441 metres; 50 kW. Relayed by **Naples**, 941 kc/s, 319 metres; **Milan (Vigentino)**, 662 kc/s, 453.1 metres, from 7.45 p.m.; and **2RO**, 11,810 kc/s, 25.4 metres.—12 **Noon** to 1.15 p.m., Orchestral Concert: Per te sarò tenets (Brancucci); Prelude to and Minuet from L'Arlesienne (Bizet); Anna capriciosa (Sarpny); Serenata (Ciolotta); Selection from La Bohème (Puccini); El Caballero (Rossi); Rumanian Rhapsody (Krumann); Bella Lolita (d'Anzi). In the intervals from 12.30 to 12.45, **Giornale Radio**, and at 1.0, Time and Announcements. 3.30, Children's Radio Review. 3.55, **Giornale Radio** and Report of the Royal Geographical Society. 4.10, Weather. 4.15 to 5.0, Orchestral Concert: Selection from White Horse Inn (Stolz-Benatzky); Sinfonietta veneziana (Principe); Waltz (Esobar); Soleya (Chesi); Selection from Andrea Chénier (Giordano); Giardino chiuso (Amadei); Only a night (Roland). 5.40 (**Naples**), Shipping and Sports Notes. 5.45, Lesson in Morse and Dopolarvo Report. 6.0, Tourist Report. 6.10, Wheat Market Report. 6.20, News in Foreign Languages. 6.40, **Giornale Radio**. 7.0, Time and Announcements. 7.15, Gramophone Music. 7.30, **Giornale Radio** and Sports Notes. 7.45, Concert, conducted by Andrea Marchesini. In the intervals, Talk and Scientific Review. 10.0, **Giornale Radio**.

**SALZBURG**.—See Vienna.

**SCHENECTADY**

**WCY**, 790 kc/s, 375.5 metres; 50 kW. Relayed at intervals by **W2XAF** on 31.48 metres and by **W2XAD** on 19.56 metres.—12.45 a.m. (**Sunday**), Stock Reports. 1.0, Popular Programme. 1.30, Antobals Cubans, from **New York**. 1.45, Club Programme. 2.0 to 4.0, **New York** Relay. 2.0, Popular Programme. 2.30, Variety Programme. 3.0, Saturday Dancing Party. 4.0, Programme Résumé.

**SCHWEIZERISCHER**

**LANDESENDER**

**BEROMUNSTER**, 653 kc/s, 459 metres; 60 kW; **Basle**, 1,229 kc/s, 244.1 metres; and **Berne**, 1,220 kc/s, 245.9 metres.—5.50 a.m. to 6.5 (from **Berne**), Gymnastics. 11.0 (from **Berne**), Gramophone Music. 11.29, Time Signal from Neuchâtel Observatory, followed by Weather and News. 11.40 (from **Berne**), Review of the Week's Events in the Federal Parliament. 11.50 (from **Berne**), Light Music on Gramophone Records. 12.15 p.m. (from **Berne**), Song Recital. 12.25 (from **Berne**), Time, Weather and Exchange. 12.30 (from **Berne**), The Listener's Quarter-of-an-hour. 12.45 (from **Berne**), Book Review. 1.15 (from **Berne**), Gramophone Music. 1.30 (from **Berne**), Talk: The Motor Car on the Alpine Roads in Winter. 2.0, Interval. 3.0 (from **Berne**), Concert by the Frohsinn Hand-Harp Club. 3.30 (from **Berne**), Thirty Years Ago—Radio Sequence from Old Newspapers (Franziskus). 3.45, Programme relayed from **Lugano**. 5.0 (from **Basle**), Marches on Gramophone Records. 5.30 (from **Basle**), Programme for Young People. 6.0, Chimes from the Zürich Churches. 6.15 (from **Basle**), Time, Weather and Exchange. 6.20 (from **Basle**), Opera and Operetta Music on Gramophone Records. 7.0 (from **Basle**), Dutch Programme. In the interval at 8.0 (approx.), Weather and News. 9.15 (from **Basle**), Dance Music on Gramophone Records. 10.0 (approx.), Close Down.

**SOTTENS**.—See Radio-Suisse Romande.

**STOCKHOLM**

689 kc/s, 436 metres; 55 kW. Relayed by **Boden**, 242 kc/s, 1,239.5 metres; **Göteborg**, 932 kc/s, 322 metres; **Hörby**, 1,167 kc/s, 257 metres; **Motala**, 222 kc/s, 1,348 metres; **Ostersund**, 402 kc/s, 746.2 metres; and **Sundsvall**, 554 kc/s, 542 metres.—3.0 p.m., Technical Talk. 3.20, Light Orchestral Music: Selection from New Moon (Romberg); Erotikon No. 2 (Sjögren); Minuet (Petre); Serenata alla Luna (De Micheli); I Live for

love from Ball at the Savoy (Abraham); Foxtrot from A Midnight Tango (Komzak). 4.5, Programme for Children, relayed from **Örebro**, 1,265 kc/s, 237.2 metres. 4.30, Song Recital by Thelma Winge. 4.45, Gramophone Music. 5.45, Talk on Spain. 6.15, Weather and News. 6.30 (from **Göteborg**), Old Dance Music. 7.0, Military Band Concert, conducted by Grundström: Overture, Der Freischütz (Weber); Ballet Music from The Prophet (Meyerbeer); Ständchen (Schubert); Extracts from Don Carlos (Verdi); 1812 Overture (Tchaikovsky). 8.0, Cabaret Programme. 8.45, Weather and News. 9.0, Dance Music. 10.0 (approx.), Close Down.

**STRASBOURG**

869 kc/s, 345 metres; 11.5 kW.—11.30 a.m., Gramophone Concert. 12.45 p.m., News. 1.0, Time. 1.1, Variety Concert, conducted by Roskam. 2.0, Legal Talk in German. 2.15, Gramophone Concert. 3.0, Talk on Music: The End of the Impressionist Movement. 3.15, Interval. 4.0, Dance Music on Gramophone Records. 5.0, Symphony Concert by the Padeloup Concert Society, relayed from the Théâtre des Champs Elysées, Paris. 7.0, French Lesson. 7.15, Talk: The Treatment of Fruit Trees in Winter. 7.30, Time and News. 7.45, Gramophone Records. 8.0, Press Review in German, Lottery Results and Announcements. 8.30, Un Soir de Réveillon—Radio Film (after an Operetta by Abraham). 10.30 (approx.), News, followed by Dance Music, relayed from the Savoy. 12 **Midnight**, Close Down.

**STUTTGART**

**MUHLACKER**, 832 kc/s, 360.5 metres; 1.5 kW. Relayed by **Freiburg**, 527 kc/s, 570 metres.—12.15 p.m., See **Frankfurt**. 12.25, Local News. 12.35, Gramophone Concert. 1.30, Programme for Young People. 2.30, Concert by the Stuttgart Mandoline Orchestra, conducted by Leo Hantz: Landknechtsmarsch; Julia Serenata (Francheschi); Gondellied (Hantz); Stolzenfels am Rhein (Meissler); March, Mein Regiment (Blankenberg); Veilchen aus Abbazia (Wenzel); Die Jugend marschert (Lindemann). 3.0, See **Langenberg**. 5.0 to 5.35, See **Frankfurt**. 5.35, Talk: Southern Germany in Prehistoric Times. 5.50, Time and Announcements. 6.0, Transmission for all German Stations, relayed from **Hamburg**. 7.0 to 9.20, See **Frankfurt**. 9.20, Talk: Things you should know. . . . 9.30, Local News. 9.45 to 12.15 a.m. (**Sunday**), See **Langenberg**. 12.15, Die Sieben Schwaben—Radio Sequence of Swabian Songs, Dances and Anecdotes (arr. Martin Lang and Gustav Görlsch), by a Double Quartet, a Peasant's Orchestra and Soloists. 1.15 (approx.), Close Down.

**SUNDSVALL**.—See Stockholm.

**TOULOUSE**

779 kc/s, 385 metres; 8 kW.—6.0 p.m., News. 6.15, Orchestral Music. 6.30, Operetta Music: Arias from La vie parisienne (Offenbach); Marietta (O. Straus); Azor (Gabaroché); and Marius à Paris (Mahieux). 6.45, Music by an Argentine Band. 7.0, Songs. 7.15, News and Exchange. 7.30, Overture, William Tell (Rossini), by the Station Orchestra. 7.45, Opera Music: Arias from Louise (Charpentier); Sappho (Massenet); Manon (Massenet); and Don Quixote (Massenet). 8.0, Orchestral Music: Potpourri of Classical Music; Selection from Muzelle Nitouche (Hervé); Selection from Le pays du soleil (Scott). 8.15, Chansonnettes. 8.30, Accordion Solos. 8.45, Military Band Music. 9.0, Concert Version of La mascotte—Operetta (Audran). 9.30 (approx.), Orchestral Concert: Three Pieces (Satie); Berceuse from The Fire Bird (Stravinsky); Entry March of the Gladiators (Fucik); Toréador et Andalouse (Rubinstein); Heintzelmann's Wachtparade (Noack); Overture, Raymond (Thomas). 10.0, Russian Songs and Balalaika Music. 10.15, News. 10.30, Music by an Argentine Band, followed by Music from Sound Films. 11.0, Request Music. 11.15, Dance Music. 12 **Midnight**, News, Weather, and Announcements. 12.5 a.m. (**Sunday**), Light Music by a Viennese Orchestra: Potpourri, Around the Volga (Borchart); Hungarian Potpourri; Waltz Potpourri (Hildebrandt); Wiener Kinder (Strauss). 12.30 (approx.), Close Down.

**TRIESTE**

1,211 kc/s, 247.7 metres; 10 kW.—4.10 p.m. till Close Down, See **Turin**.

**TRONDHEIM**.—See Oslo.

**TURIN**

1,096 kc/s, 273.7 metres; 7 kW. Relayed by **Milan**, 903 kc/s, 332.2 metres; **Genoa**, 959 kc/s, 312.8 metres; and **Florence**, 598 kc/s, 501.6 metres.—4.10 p.m., Gramophone Music. 5.0 to 5.5, Weather. 5.40, **Giornale Radio**, Announcements and Gramophone Music. 6.0, Time, Tourist Report and Gramophone Music. 6.10, Wheat Market Report. 6.20,

News in Foreign Languages. 6.40, Gramophone Music. 7.0, **Giornale Radio** and Weather. 7.25, Talk: Events and Problems. 7.40, Variety Programme. 8.45, Review of New Books. 9.0, Dance Music. 10.0, **Giornale Radio**.

**VATICAN CITY**

15,120 kc/s, 19.84 metres (**Morning**) and 5,969 kc/s, 50.26 metres (**Evening**); 10 kW.—10.0 to 10.15 a.m., Religious Information in Various Languages. 7.0 to 7.15 p.m., Religious Information in Italian.

**VIENNA**

580 kc/s, 517.2 metres; 100 kW. Relayed by **Graz**, 852 kc/s, 352.1 metres; **Innsbruck**, 1,058 kc/s, 283 metres; **Klagenfurt**, 662 kc/s, 453.1 metres; **Linz**, 1,220 kc/s, 245.9 metres; and **Salzburg**, 1,373 kc/s, 218.5 metres.—11.0 a.m., Orchestral Concert, conducted by Otto Wacke. In the interval at 12 **Noon**, Time and News. 1.0, Interval. 2.0, Time, Weather and Exchange. 2.15, Italian Conversation. 2.40, Mandoline Concert: Selection from Il Trovatore (Verdi); Polka, Frauenherz (Joh. Strauss); Waltz, Violetta di Parma (Beucucci); Intermezzo, Yoja (Johnson); Leuchtkäferchens Stelldichein (Siede); Spanish Dance (Metras). 3.20, Talk. 3.45, Talk: The Swamps and Steppes in Winter. 4.10, Orchestral Concert, conducted by Julius Herrmann: Starhenberg-Marsch (Ritzberger); Overture, Light Cavalry (Suppe); Waltz from Eva (Lehar); Selection from The Gipsy Princess (Kalmán); Die Dorfmusik (Fryberg); Song Potpourri Servus Wien (Dostal); Waltz, Badner Madln (Komzak); March, Tiroler Adler (Acheithner). 5.15, Topical Programme. 5.45, Recital of Folk Songs by the German Folk Song Society of Vienna, Lina Gröschl (Soprano) and Elsa Riehar (Pianoforte); Introductory Talk by Dr. Karl Kotek. 6.45, Time, Weather, Sports Report and Programme Announcements. 6.55, To-day's Motto. 7.0, Concert in Aid of the Vienna Winter Relief Fund, relayed from the Musikvereinsaal. In the interval, News. After the Programme, Gramophone Concert and Announcements.

**WARSAW**

212.5 kc/s, 1,411 metres; 120 kW.—10.57 a.m., Time Signal and Fanfare from St. Mary's Church, Cracow. 11.5, Classical Music on Gramophone Records. 11.30, Radio Journal. 11.35, Weather. 11.38, Gramophone Music (contd.). 12 **Noon**, Interval. 2.25, News and Economic Notes. 2.40, Shooting Notes. 2.55, Aviation Notes and Anti-Gas Report. 3.0, Song Recital by Cecile Wegrzynowska. 3.20, Programme for Invalids, relayed from **Lwów**, 788 kc/s, 381 metres.—3.40, French Lesson. 4.0, Divine Service, relayed from **Wilno**, 530 kc/s, 566 metres. 5.0, Reading. 5.20, Barytone and Violin Recital by Zelechowski and Tawroszewicz: Arias from (a) A Masked Ball (Verdi), (b) Nero (Rubinstein); Song, The Prisoner (Gretchanov); Violin Solo: Rondo capriccioso (Saint-Saëns); Baritone Solos: (a) La coupe de ma vie (E. Walter), (b) March (Tosti), (c) Torna amore (Buzzi-Peccia); Violin Solos: (a) Humoresque (Tchaikovsky-Kreisler), (b) Berceuse (Stravinsky), (c) Serenade (Chaminade), (d) Tarantella (Wieniawski). 6.0, Programme Announcements. 6.5, Miscellaneous Items. 6.25, Reading from the Works of Marshal Piłsudski. 6.40, Sports Notes. 6.47, Radio Journal. 6.55, Interval. 7.0, Concert by the Station Orchestra, conducted by Nawrot. Soloist: Witas (Tenor). Selection from La Princesse de Trébizonde (Offenbach); Three Tenor Solos from Les cloches de Corneville (Planquette); Serenade (Schloek); Songs; Waltz, Danube Pearls (Vollstedt); Krakovia (Sygietyński); Mazurka (Wrónski). 8.0, Answers to Correspondents. 8.20, Chopin Pianoforte Recital by Marguerite Trombini-Kazuro; Polonaise in C Minor, Op. 40; Scherzo in B Flat Minor, Op. 31; Etude in A Flat, Op. 25; No. 1 Etude in A Flat; Fantasia in F Minor, Op. 49; Mazurka in F Minor; Waltz in A Flat, Op. 34. 9.0, Talk in French: Work in Poland. 9.15, Dance Music on Gramophone Records. 10.0, News. 10.5, Dance Music, relayed from the Café Gastronomie.

**WILNO**

530 kc/s, 566 metres; 16 kW.—6.20 p.m., Miscellaneous Items. 6.25, See **Warsaw**. 6.45, Announcements. 6.47, See **Warsaw**. 7.0, Programme for the 10th Anniversary of the Foundation of the Wilno Conservatoire, relayed from the Conservatoire: Addresses; Overture, Bajka (Mousszko); Songs; Pianoforte Concerto (Rozycki). 8.0, Request Gramophone Records. 9.0, Educational Talk. 9.15, See **Warsaw**. 11.0 (approx.), Close Down.

**ZAGREB**

977 kc/s, 307 metres; 0.75 kW.—4.0 p.m., Concert by the Simacek-Sever-Kerp Trio. 5.30 to 6.5, Interval. 6.5, Talk. 6.35, Sports Notes. 6.45, Announcements. 7.15, Orchestral Concert; Soloist, Margita Bornstein (Soprano). 8.15, Concert of Light Music by the Radio Orchestra. 8.45, Dance Music. 9.0, News, Weather, and Programme Announcements. 9.15, Dance Music. 10.0 (approx.), Close Down.

**ZURICH**.—See Schweizerischer Landessender.

# PRINCIPAL BROADCASTING STATIONS OF EUROPE

Arranged in Order of Wavelength

Metres.	kc/s.	kW.	Station.	Tuning Positions.	Metres.	kc/s.	kW.	Station.	Tuning Positions.
1935	155	7	Kaunas (Kovno) (Lithuania)		364.1	824	1	Bergen (Norway)	
1875	160	8.5	Huizen (Holland) ( <i>Kootwyk</i> , 50kW., after 3.40 p.m.) ( <i>K.R.O. and N.C.R.V. programmes.</i> )		363.6	825	13	Algiers (Algeria)	
1796	167	50	Lahti (Finland)		360.6	832	1.5	Mühlacker (Stuttgart) (Germany)	
1725	174	75	Radio Paris, CFR		355.9	843	50	London Regional (Brookmans Park)	
1635	183.5	60	Berlin (Deutschlandsender) (Germany). ( <i>S.-W. Stn. DJA on 31.38 m., DJB on 19.73 m., DJC on 49.83 m., DJD on 25.51 m., DJE on 16.86 m.</i> )		352.1	852	7	Graz (Austria). ( <i>Relays Vienna</i> )	
1554.4	193	30	Daventry National		348.8	860	7.6	Barcelona, EAJ1 (Spain)	
1546	194	7	Ankara (Angora) (Turkey)		348.8	860	10	Leningrad, RV70 (Russia)	
1481	202.5	500	Moscow, RV1 (Russia) ( <i>S.-W. Stn. on 25m.</i> )		345.2	869	11.5	Strasbourg, PTT (France)	
1446	207.5	13	Eiffel Tower, FL, Paris		341.7	878	35	Brno (Brunn) (Czechoslovakia)	
1412	212.5	120	Warsaw I (Poland)		337.8	888	15	Brussels II Velthem (Belgium). ( <i>In Flemish</i> )	
1380	217.5	100	Novosibirsk, RV76 I (Russia)		335	896	5	Cadix (Spain)	
1348	222.5	30	Motala (Sweden). ( <i>Relays Stockholm</i> )		334.4	897	1.9	Poznan (Poland)	
1304	230	100	Moscow, WZSPS (Trade Union) (Russia)		331.5	905	50	Milan (Italy). ( <i>Relays Turin</i> )	
1200	250	5	Stamboul (Turkey)		328.2	914	60	Poste Parisien (France)	
1200	250	21	Reykjavik (Iceland)		325	923	60	Breslau (Germany)	
1190	252	200	Luxembourg		321.9	932	10	Göteborg (Sweden). ( <i>Relays Stockholm</i> )	
1170	256	25	Tashkent, RV11 (Russia)		318.8	941	0.25	Dresden (Germany). ( <i>Relays Leipzig</i> )	
1154	260	30	Kalundborg (Denmark). ( <i>Relays Copenhagen</i> )		318.8	941	1.5	Naples, INA (Italy). ( <i>Relays Rome</i> )	
1154	260	20	Monte Ceneri (Switzerland)		315.8	950	1.6	Marseilles, PTT (France)	
1117	268.5	40	Moscow, Popoff RV58 (Russia)		312.8	959	1.7	Cracow (Poland)	
1083	277	60	Oslo (Norway)		312.8	959	10	Genoa, IGE (Italy). ( <i>Relays Turin</i> )	
1071	280	35	Tiflis, RV7 (Russia)		309.9	968	50	West Regional (Washford Cross)	
1035	290	36	Kiev, RV9 (Russia)		307	977	0.7	Radio Vitus (Paris). ( <i>S.-W. Stn. on 43.75 m.</i> )	
1000	300	100	Moscow RV49 (Russia). ( <i>S.-W. Stn. on 50 m.</i> )		307	977	0.75	Zagreb (Yugoslavia)	
998	320	20	Kharhov, RV4 (Russia)		304	986	13	Bordeaux Lafayette, PTT (France)	
857	350	100	Leningrad (Russia)		301.5	995	50	North National (Manchester)	
840	357	18.5	Budapest (Hungary)		298.8	1004	11	Tallinn (Estonia)	
800	375	50	Sverdlovsk, RV5 (Russia)		296.1	1013	20	Hilversum (Holland). ( <i>7 kW. before 4.40 p.m.</i> ) ( <i>V.A.R.A., A.V.R.O. and V.P.R.O. programmes.</i> )	
750	400	1.3	Geneva (Switzerland). ( <i>Relays Sottens</i> )		293.5	1022	0.7	Limoges, PTT (France)	
720	416.6	20	Moscow, RV2 (Experimental) (Russia)		293.5	1022	2.6	Kosice (Czechoslovakia)	
689	436	1.5	Oulu (Uleaborg) (Finland)		291	1031	13.2	Viipuri (Viborg) (Finland). ( <i>Relays Helsinki</i> )	
574.7	522	0.7	Hamar (Norway) ( <i>Relays Oslo</i> )		288.3	1040	50	Scottish National (Falkirk)	
574.7	522	7	Ljubljana (Yugoslavia)		288.3	1040	1	Bournemouth. ( <i>Relay Station</i> )	
570	527	0.25	Freiburg ( <i>Relays Muhlacker</i> )		286	1049	0.8	Montpellier (France)	
568.1	528	2	Grenoble (France)		284.8	1053	0.7	Lyons (Radio-Lyon) (France)	
565	531	16	Wilno (Poland). ( <i>Relay Station</i> )		283.6	1058	0.5	German Relays (Berlin, Magdeburg, Stettin)	
560	536	1.5	Kaiserslauten and Augsburg ( <i>Relay Munich</i> )		283.6	1058	0.5	Innsbruck (Austria). ( <i>Relays Vienna</i> )	
550	545	18.5	Budapest No. 1 Lakihegy (Hungary)		282.2	1063	2	Lisbon CT 1AA (Portugal). ( <i>Short-wave Station on 31.25 m.</i> )	
542	554	10	Sundsvall (Sweden). ( <i>Relays Stockholm</i> )		281.2	1067	0.75	Copenhagen (Denmark)	
539.6	556	3	Palermo (Italy)		278.8	1076	13.5	Bratislava (Czechoslovakia)	
533	563	60	Munich (Germany)		276.5	1085	60	Heilsberg (Germany)	
525	571	15	Riga (Latvia)		273.7	1096	7	Turin (Italy)	
517.2	580	100	Vienna (Bisamberg) (Austria)		271.5	1105	1.3	Rennes, PTT (France)	
509	589	15	Brussels No. 1, Velthem (Belgium). ( <i>In French</i> )		269.8	1112	20	Bari (Italy) ( <i>Relays Rome</i> )	
501.6	598	20	Florence, IPI (Italy) ( <i>Relays Turin</i> )		267.6	1121	0.75	Valencia (Spain)	
495.8	605	1.2	Trøndelag (Norway)		267.4	1122	6.25	Nvireghaza (Hungary). ( <i>Relays Budapest</i> )	
488.6	614	120	Prague (Czechoslovakia)		265.8	1128.5	1.3	Lille, PTT (France)	
480	625	50	North Regional (Manchester)		263.8	1137	11.2	Moravska Ostrava (Czechoslovakia)	
472.4	635	60	Langenberg (Germany)		261.5	1147	50	London National and West National	
465.8	644	1.5	Lyons la Doua, PTT (France)		259.3	1157	17	Frankfurt-a.-M. (Germany)	
459.4	653	60	Beromünster (Schweizerischer Landessender) (Switzerland)		259.3	1157	2.3	Trier and Cassel. ( <i>Relay Frankfurt</i> )	
453.2	662		San Sebastian, EAJ8 (0.6 kW.); Klagenfurt (0.5 kW.) (Austria) ( <i>relays Vienna</i> )		257.1	1167	10	Hörby (Sweden). ( <i>Relays Stockholm</i> )	
453.2	662	0.25	Agen (France)		255.1	1176	0.7	Toulouse, PTT (France)	
453.2	662	4	Milan (Vigentino) (Italy). ( <i>Relays Rome</i> )		253.1	1185	5	Gleiwitz (Germany). ( <i>Relays Breslau</i> )	
451.8	664	20	Madona (Latvia). ( <i>Relays Riga</i> )		252	1193	1	Barcelona, EAJ15 (Assoc. Nat.) (Spain)	
447.1	671	0.5	Danzig ( <i>Relays Heilsberg</i> )		249	1205	0.8	Juan-les-Pins, Nice (France)	
447.1	671	7	Paris, Ecole Supérieure, PTT		247.7	1211	10	Trieste (Italy). ( <i>Relays Turin</i> )	
441.2	680	50	Rome, IFO. ( <i>S.-W. Station, 2RO on 25.4 m.</i> )		245.9	1220		Berne (0.5kW.) (Switzerland) ( <i>relays Beromünster</i> ): Eskilstuna (0.2kW.), Säfte (0.4 kW.) (Sweden) ( <i>relays Stockholm</i> ); Linz (0.5 kW.) (Austria) ( <i>relays Vienna</i> ); Turku (Abo) (0.5 kW.) (Finland) ( <i>relays Helsinki</i> ).	
435.4	689	55	Stockholm, SASA (Sweden)		244.1	1229	0.5	Basle (Switzerland). ( <i>Relays Beromünster</i> )	
429.7	698	2.5	Belgrade (Yugoslavia)		242.3	1238	1	Belfast (N. Ireland)	
424.3	707	2	Madrid, EAJ7 (Union Radio)		240.6	1247	0.5	Stavanger (Norway)	
424.3	707	100	Moscow, Imini Stalina (Russia)		238.9	1256	2	Nürnberg (Germany). ( <i>Relays Munich</i> )	
419.5	715	1.5	Berlin, Funkstunde (Germany)		233	1260	1	Nimes (France)	
416.4	720.5	5	Rabat (Morocco)		237.2	1265	3	Bordeaux, Sud-Ouest (France)	
413	725	60	Athlone (Irish Free State)		235.5	1274	0.5	Kristiansand (Norway)	
408.7	734	16	Katowitz (Poland)		233.8	1283	1.65	Lodz (Poland). ( <i>Relay Station</i> )	
403.8	743	25	Sottens (Radio Suisse Romande) (Switzerland)		232.2	1292	0.25	Kiel (Germany). ( <i>Relays Hamburg</i> )	
398.9	752	25	Midland Regional (Daventry)		230.6	1301		Swedish Relay Stations	
394.2	761	12	Bucharest (Roumania)		227.4	1319		Flensburg, Bremen and Hanover. ( <i>Relay Hamburg</i> )	
389.6	770	120	Leipzig (Germany)		225.9	1328	10	Fécamp, Radio-Normandie (France)	
385.1	779	8	Toulouse (Radiophonie du Midi) (France)		224.4	1337	1	Cork (Irish Free State) ( <i>Relays Athlone</i> )	
385.1	779	10	Stalino, RV26 (Russia)		219.9	1365	1.5	Béziers (France)	
381	788	16	Lwow (Lemberg) (Poland)		218.5	1373	0.2	Plymouth	
376.4	797	50	Scottish Regional (Falkirk)		218.5	1373	0.5	Salzburg (Austria). ( <i>Relays Vienna</i> )	
372.2	806	1.5	Hamburg (Germany)		217	1382	1.2	Dublin ( <i>Relays Athlone</i> )	
366.7	818	0.8	Radio, LL, Paris		217	1382	0.5	Königsberg (East Prussia). ( <i>Relays Heilsberg</i> )	
368.1	815		Seville, EAJ5 (Union Radio) (1.0 kW.); Galicia EAJ4 (0.2 kW.) (Spain); Bolzano (1.0 kW.) (Italy); Helsinki (10 kW.) (Finland) ( <i>relays Lahti</i> ); Kharkov, RV20 (10kW) (Russia)		214.3	1400	1	Aberdeen	
368.1	815	0.7	Fredriksstad (Norway). ( <i>Relays Oslo</i> )		211.3	1420	1	Newcastle	
					209.8	1430	1.25	Magyarovar, Miskolc and Pecs (Hungary)	

# SHORT-WAVE STATIONS OF THE WORLD

(N.B.—Times of Transmission given in parentheses are approximate only and represent G.M.T.)

Metres.	kc/s.	Call Sign.	Station.	Tuning Positions.	Metres.	kc/s.	Call Sign.	Station.	Tuning Positions.
62.56	4,795	VE9BY	London, Ont. (Canada). (Sun. 06.00) ...		31.54	9,510	GSB	Empire Broadcasting	
58.31	5,145	OK1MPT	Prague (Czechoslovakia). (Tues. and Fri. 19.30) ...		31.43	9,530	W2XAF	Schenectady, N.Y. (U.S.A.). (Relays WGY)	
50.26	5,970	HVJ	Vatican State, Rome. (Daily 19.00) ...		31.33	9,560	DJA	Zeesen (Germany). (Daily 22.00) ...	
50.0	6,000	RW59	Moscow. (Relays Komintern Stn.) ...		31.35	9,570	W1XAZ	East Springfield, Mass. (U.S.A.). (Relays WBZ)	
50.0	6,000	EAR25	Barcelona, Radio Club (Spain). (Sat. 20.00) ...		31.3	9,580	HLB	Radio Nations, Prangins (Switzerland). (Sat. 22.00-22.45) ...	
49.83	6,020	DJC	Zeesen (Germany) ...		31.29	9,585	GSC	Empire Broadcasting	
49.67	6,040	W1XAL	Boston, Mass. (U.S.A.) ...		31.28	9,590	W3XAU	Philadelphia, Pa. (U.S.A.). (Relays WCAU)	
49.64	6,040	W4XB	Miami Beach, Florida (U.S.A.) ...		31.28	9,590	VK2ME	Sydney (Australia). (Sundays) ...	
49.58	6,050	GSA	Empire Broadcasting		31.25	9,598	CT1AA	Lisbon (Portugal). (Tues. and Fri. 22.00-00.00) ...	
49.5	6,060	W3XAU	Philadelphia, Pa. (U.S.A.). (Relays WCAU)		31.0	9,675	T14NRH	Heredia (Costa Rica). (Daily 22.00 and 02.00) ...	
49.5	6,060	VQ7LO	Nairobi (Kenya Colony). (Daily 16.30) ...		30.0	10,000	EAQ	Aranjuez (Spain). (Daily 22.30, Sat. 18.00) ...	
49.43	6,069	W8XAL	Mason, Ohio (U.S.A.). (Relays WLW) ...		28.98	10,350	LSX	Buenos Aires (Argentina). (Daily 20.30)	
49.40	6,075	VE9CS	Vancouver, B.C. (Canada) ...		26.83	11,180	CT3AQ	Funchal (Madeira). (Tues. and Thurs. 10.30-12.30) ...	
49.40	6,075	OXY	Skamlebaek (Denmark). (Relays Copenhagen)		25.63	11,705	FYA	Pontoise (France). (Colonial Stn. E-W, daily 20.30) ...	
49.34	6,080	W9XAA	Chicago, Ill. (U.S.A.). (Relays WCFL) ...		25.6	11,720	VE9JR	Winnipeg (Canada). (Daily 11.30) ...	
49.22	6,095	VE9GW	Bowmanville, Ont. (Canada). (Daily 20.00)		25.57	11,730	PHI	Eindhoven (Holland) ...	
49.2	6,098	ZTJ	Johannesburg (S. Africa). (Weekdays 09.00-14.00 [Sat. 14.30] and 17.00, Sun. 13.00 and 16.30.) ...		25.53	11,750	GSD	Empire Broadcasting	
49.18	6,100	W3XAL	Bound Brook, N.Y. (Relays WJZ) ...		25.5	11,760	DJD	Zeesen (Germany) ...	
49.18	6,100	W9XF	Downers Grove, Ill. (U.S.A.) ...		25.45	11,790	W1XAL	Boston, Mass. (U.S.A.) ...	
49.1	6,110	VUC	Calcutta, India. (Daily 13.00) ...		25.4	11,810	2RO	Prato Smeraldo, Rome. (16.15-23.30) ...	
49.02	6,120	W2XE	Wayne, N.J. (U.S.A.). (Relays WABC) ...		25.36	11,830	W2XE	Wayne, N.J. (U.S.A.). (Relays WABC) ...	
48.86	6,140	W8XK	East Pittsburg, Pa. (U.S.A.). (Relays KDKA 21.19-06.00) ...		25.36	11,830	W9XAA	Chicago, Ill. (U.S.A.). (Relays WCFL) ...	
47.97	6,250	HJ3ABF	Bogota (Colombia). (Daily 15.00) ...		25.28	11,865	GSE	Empire Broadcasting	
48.05	6,243	HKD	Barranquilla (Colombia). (Weekdays 23.45)		25.27	11,870	W8XK	East Pittsburg, Pa. (U.S.A.). (Relays KDKA 21.19-03.00) ...	
48.0	6,250	CN8MC	Casablanca (Morocco). (Relays Rabat) ...		25.25	11,880	FYA	Pontoise (France). (Colonial Stn. N-S) ...	
47.0	6,382	HCDR	Quito, Ecuador. (Daily 01.00) ...		25.0	12,000	RNE	Moscow. (Relays R.F.1) ...	
46.69	6,425	W3XL	Bound Brook, N.J. (U.S.A.). (Relays WJZ) ...		23.58	12,830	CNR	Rabat (Morocco). (Sun. 12.30) ...	
45.38	6,610	RW72	Moscow. (Relays Stalin Stn.) ...		19.84	15,120	HVJ	Vatican State, Rome. (Daily 10.00) ...	
45.0	6,667	FM8KR	Constantine (Algeria). (Mon. and Fri. 22.00) ...		19.81	15,140	GSF	Empire Broadcasting	
45.0	6,667	TGW	Guatemala City (Central America). (Daily 03.00) ...		19.73	15,200	DJB	Zeesen (Germany). (Daily 13.00-22.30) ...	
43.75	6,860	---	Radio Vitus, Paris. (Daily 20.30) ...		19.72	15,210	W8XK	East Pittsburg, Pa. (U.S.A.). (Relays KDKA 15.00-21.18) ...	
43.0	6,970	EAR110	Madrid. (Tues. and Sat. 22.30) ...		19.68	15,244	FYA	Pontoise (France). (Colonial Stn. E-W) ...	
41.7	7,195	VS1AB	Singapore (Malay States). (Sun. and Wed. 15.30) ...		19.64	15,270	W2XE	Wayne, N.J. (U.S.A.). (Relays WABC) ...	
40.3	7,443	HBQ	Radio Nations, Prangins (Switzerland) (Sun. 22.00-22.45) ...		19.57	15,330	W2XAD	South Schenectady, N.Y. (U.S.A.). (Daily 20.00) ...	
38.47	7,797	HBP	Radio Nations, Prangins (Switzerland). (Sat. 22.30-23.15) ...		16.89	17,760	DJE	Zeesen (Germany) ...	
37.33	8,936	CNR	Rabat (Morocco). (Sun. 21.00) ...		16.88	17,770	PHI	Eindhoven (Holland) ...	
37.04	8,110	HCJB	Quito (Ecuador) ...		16.87	17,780	W3XAL	Bound Brook, N.J. (Relays WJZ) ...	
33.50	8,955	TGX	Guatemala City (S. America) ...		16.87	17,780	W9XAA	Chicago, Ill. (U.S.A.). (Relays WCFL) ...	
31.58	9,500	PRBA	Rio de Janeiro (Brazil). (Daily 21.30) ...		16.87	17,780	W9XF	Downers Grove, Ill. (U.S.A.) ...	
31.55	9,510	VK3ME	Melbourne (Australia). (Wed. and Sat. 10.00) ...		16.86	17,790	GSG	Empire Broadcasting	
					13.97	21,470	GSH	Empire Broadcasting	
					13.92	21,540	W8XK	East Pittsburg. (12.00-19.00) ...	
					12.30	24,380	VE9GW	Bowmanville, Ont. (Canada) ...	

## A Well-equipped Amateur Transmitting Station

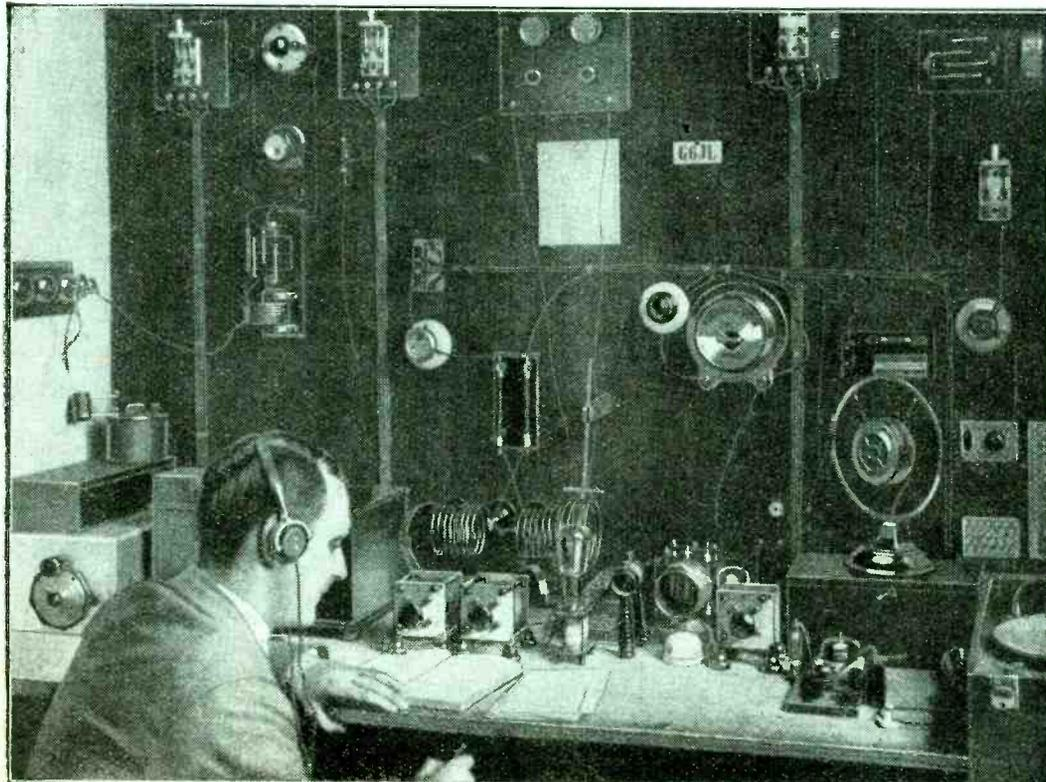

Mr. J. C. Lee operating his station G6JL at Spinney Lane, Kettering. Telegraphy and telephony are conducted on 7,166 and 14,332 kc/s., and also on 1,730 and 1,985 kc/s.

## FOREIGN BROADCAST GUIDE

### KALUNDBORG

(Denmark).

Geographical position: 55° 40' 18" N.; 11° 04' 20' E.  
Approximate air line from London: 535 miles.

Wavelength: 1,153.8 m. Frequency: 260 kc/s.  
Power: 60 kW.

Standard time: Central European (one hour ahead of G.M.T.).

#### Standard Daily Transmissions (Relays Copenhagen)

06.00 G.M.T., physical exercises (Sundays 07.00);  
09.10, relay of Sacred Service from Cathedral (Sun.);  
11.00, time signal and chimes from Copenhagen Town Hall;  
12.30, talks in English, German and French (Sun.);  
16.00, relay of Sacred Service (Sun.); 17.00, talks, news, etc.;  
19.00, time signal and chimes; 19.30, main evening entertainment;  
22.10, dance music (relayed), interrupted at 23.00 by time signal and chimes. Usually closes down 23.30.

Announcers: Man and woman; the latter usually for daylight broadcasts only.

Call: Kalundborg-Kobenhavn og Danmarks Kortbolgesender (short wave transmitter).

Opening signal: Musical box melody repeated *ad lib.*:



Before closing down the studio prior to an outside relay of dance music, the announcer gives the following day's programme, concluding with: *God nat, God nat*, and three strokes on a gong.

Relays: Copenhagen, 281 metres (1,067 kc/s.) 0.75 kW.  
Skamlebaek (OXY), 49.4 metres (6,075 kc/s.) 0.5 kW.

# BROADCAST BREVITIES

By Our Special Correspondent

## Better Than Loch Ness Monster

NO better breeding ground for rumour can be found than the North of Scotland at the present time, and I believe that even the Loch Ness monster is yielding pride of place to the B.B.C. mobile transmitter, which is said to be making wraith-like appearances on the misty moors and even in the Firth of Cromarty.

## Island Stronghold?

One old wives' tale has it that the Black Isle, some hundreds of yards from the Cromarty shore, is to be turned into a sort of B.B.C. Heligoland, which Press representatives and others will only be able to visit by boat.

## Nothing Doing?

How true this story may be can be gathered from the reply which I got from the B.B.C. engineering department when asking for confirmation. "Well," said the engineer, "it is an idea, isn't it?"

## Still Searching

No site has yet been chosen, but both Inverness and Culloden Moor seem to be in the running.

Down Newcastle way, too, the engineers are still testing with a mobile transmitter, but no site has yet been found for the North-Eastern Regional.

## 30-line Television to Stay

I AM able to state that a decision has been taken to continue indefinitely the 30-line television transmissions by the Baird Company from Broadcasting House. This disposes of the disturbing rumour that the simpler form of transmission would be entirely supplanted by the high definition tests at the end of March.

It is likely, however, that the time-table of 30-line transmissions will be modified. Possibly, they may be confined to one or two evenings a week.

## An Organ for Athlone?

THE admittedly beautiful tones of the B.B.C. organ seem to have struck a responsive chord in the breasts of other broadcasting organisations, and there is quite a big demand nowadays for new studio organs. Strong pleas are being made for an organ for the Dublin studio, which supplies the programmes broadcast from Athlone. It will be interesting to see whether Ireland can produce an instrument which is a worthy rival of the organ in Portland Place.

## Night Cashier

A NEW little office has been opened in one of those side corridors on the ground floor of Broadcasting House, bearing on the door the romantic sign, "Night Cashier." It is here that the artistes call immediately after completing their performance to receive their cheques.

It is the invariable rule in the B.B.C. that an artiste shall be paid immediately after the broadcast. This rule, as I understand, has never been broken save in the case of a certain famous Scots comedian who believed in C.O.D.

## Prince at Broadcast Cabaret Performance

THE Radio Manufacturers' Association is to be honoured by the presence of His Royal Highness the Prince of Wales on the occasion of the annual banquet at the Savoy Hotel on Monday next, November 27th. A cabaret performance following the banquet is to be heard by London Regional listeners.

## Jack Hylton Again

JACK HYLTON, I am glad to hear, expects to be sufficiently recovered from his illness by December 2nd to be able to appear in the studio with his Boys and give an hour's broadcast for National listeners.

## The People Who Count

FOR a moment I suspected a huge practical joke when running a swift eye over Mr. S. A. Moseley's new "Who's Who in Broadcasting." For the biography of Mr. Rees was followed by that of Dr. J. M. Rendall. There was no REITH!

Then I turned the page and found that the great name was merely in its wrong order. However, Mr. Moseley's own name was in its right order.

## Absentees

Of course, it is easy to criticise a work of this type. Looking for omissions makes a good game for a wet day. I was surprised that no room could be found for such a big figure as G. K. Chesterton, the B.B.C. book critic, and it was disturbing to find no mention of that indefatigable intermediary between the B.B.C. and the Press, Mr. Gladstone Murray.

## Useful Information

However, this "Who's Who" abounds in piquant information. Big Ben is in-

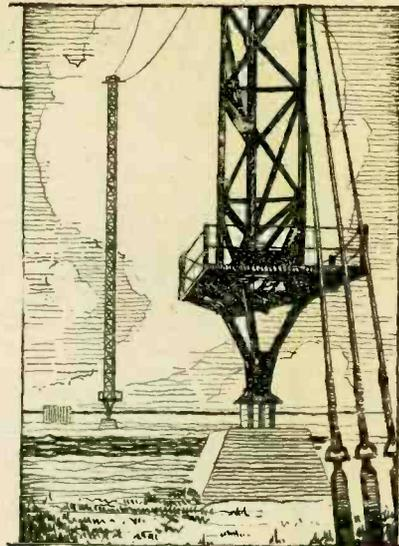

cluded as one of the "personalities," and we are told that Mr. Val Gielgud "believes in Napoleon."

## Where the Money Goes

JUST one farthing of what you and I pay for our wireless licences goes in fees to the B.B.C. Governors. This is one of the exciting facts disclosed in an unusual table printed in the B.B.C. Year Book out today (Friday). For the first time, I believe, the B.B.C. tells the world just how the net amount of 5s. 10d. available to it per licence is distributed among the various activities.

Programmes, including artists' fees, orchestras' news service and programme staff salaries account for 2s. 6½d.

## Engineers Get Elevenpence-Halfpenny

Only 11½d. is consumed by the engineering side, and this covers maintenance of plant, power, research staff salaries, and expenses.

Nasty items like rent, rates, bank interest, etc., use up another 7½d. Replacements of furniture and wireless plant take 4½d., administrative staff salaries 3½d., and the pension fund 1d.

The remaining 11½d. goes as provision for capital expenditure.

## Gramophones and Microphones

Taken as a whole, the Year Book maintains the bright and informative standard of its predecessors. Of special interest, in view of recent controversies, is the article on the application of sound recording to broadcasting.

Wireless World readers would also be interested in the notes on recent microphone developments, particularly in the direction of eliminating resonances.

## Pre-War Vintage

"SCRAPBOOK of 1913," a microphone *mélange* dealing with twenty years ago, has been arranged by Leslie Baily, and will be presented by D. H. Munro in the National programme on December 11th. The pages will be turned by Bransby Williams; but this is no history book, no portentous cavalcade—just a scrapbook of cherished fragments.

## Sun Blinds

IN *The Wireless World* of July 7th last I said that the suggested sun-blinds on the west façade of Broadcasting House would probably be fixed just as the November fogs were beginning. They were putting them up last week.



MID-OCEAN CONTROL ROOM. The microphone and short-wave receiver in the Radio cabin of the s.s. "Jacob Ruppert," which will pick up the weekly broadcasts from the Byrd Antarctic Expedition for relaying over the American Columbia network this winter.

# NEW APPARATUS REVIEWED

## Latest Products of the Manufacturers

### R. & A. "ALPHA" LOUD SPEAKER

THE method which has been adopted in this unit for mounting and centring the diaphragm and speech coil is probably the best that has so far made its appearance in commercial moving coil loud speakers. Instead of being attached to the outer chassis, the periphery of the cone is supported on a separate frame which is accurately located in the centre-pole of the permanent magnet. Thus, the alignment of the speech coil is unaffected by any damage which may be sustained by the outer chassis in its primary capacity of affording protection to the diaphragm. Further, the diaphragm-assembly can be removed for the purpose of cleaning the air gap and replaced without any fear of disturbing the alignment.

On test, the unit showed itself to possess an electro-acoustic efficiency which compared very favourably with the mains-energised standard with which it was compared. The overall response has been designed to give a good balance of tone at inputs of the order of 300 to 500 milliwatts, though the unit is well able to handle powers of the order of 5 watts. The range of maximum response is from 70 to 4,500 cycles with a bass resonance at 90 cycles and a region of increased output between 2,500 and 3,500 cycles. Below 70 cycles the output, although considerably less than the general level, is free from frequency doubling, and above 4,500 cycles the response tails off gradually to a cut-off at about 11,000 cycles.

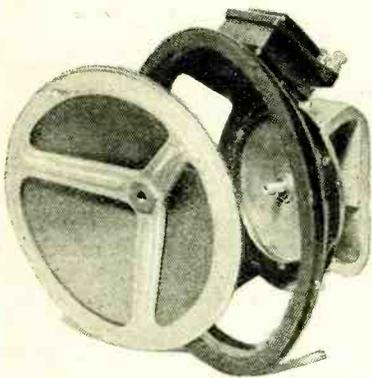

R. & A. "Alpha" loud speaker with diaphragm assembly removed for cleaning the air gap.

Output transformers are supplied for single or push-pull output stages, the former giving six ratios with effective loads from 1,500 to 15,000 ohms. The price is 52s. 6d., and the makers are Reproducers and Amplifiers, Ltd., Frederick Street, Wolverhampton.

### MILLGATE SAFETY FUSE H.T. BATTERY

WHILE an H.T. fuse is often recommended for battery sets it is most unusual to find a safeguard of this nature actually embodied in the battery. Such, however, is the case in the Millgate Safety Fuse H.T. batteries, a 60-volt unit of which we tested recently. The fuse is of the screw-in type rated at 150 mA. and fitted with a standard flash lamp base so that in

an emergency a small lamp could be employed in its place.

The battery measures 9½ in. × 3½ in. × 3 in. overall and is tapped at 12, 18 and thence in six-volt steps up to 60 volts. The fuse is at the negative end.

As it is a standard-capacity model the discharge was commenced at just below 7 mA. through a resistance of fixed value and for intermittent periods, with like intervals for recuperation. On this basis a useful life of 500 working hours was obtained by continuing the discharge until the voltage fell to the equivalent of 0.75 volt per cell or about half the nominal voltage.



Millgate 60-volt battery embodying a safety fuse.

It is of some interest to record that this arbitrary end-point coincided with the natural cut-off of the battery, for, as will be seen from the curve, it did not survive for long after. The voltage is maintained at a most satisfactory level during this period, and in this respect it compares very favourably indeed with the best in its class.

Our tests gave a watt-hour capacity of 95.5 for the battery or 2.3 watt-hour per cell, the battery comprising 41 cells. In view of the long discharge it was not surprising to find the zincs partially disintegrated, yet there was no creeping beyond the limits of the waxed cardboard partitions. It would seem that the battery has given its full measure, and at the price of 5s. 6d. is undoubtedly very good value for money. A 120-volt model of the same capacity is available at 11s.

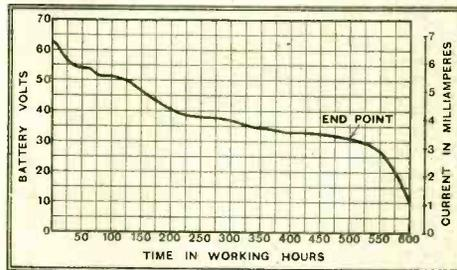

Discharge curve of Millgate Safety Fuse 60-volt H.T. battery.

The makers are Chorlton Metal Co., Ltd., Millgate House, Blossom Street, Manchester, 4.

### CLIMAX S.4 RECEIVER.

IN connection with the review of this receiver in our issue dated November 10th, the makers point out that the price given does not include the pedestal, for which an extra 2 guineas is charged.

### COLUMBIA NO. 22 PICK-UP

IN the latest pick-up designed by the Columbia Graphophone Co., Ltd., 98-108, Clerkenwell Road, London, E.C.1, an interesting innovation has been introduced

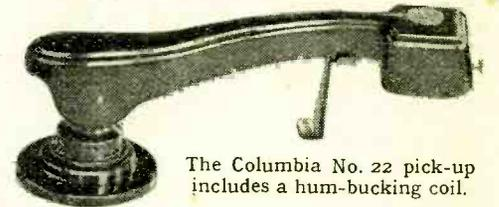

The Columbia No. 22 pick-up includes a hum-bucking coil.

in the form of a hum-bucking coil which is connected in opposition to the pick-up coil and neutralises all hum due to stray fields from the turntable motor.

The pick-up itself has an excellent frequency characteristic, the output in the horizontal middle section being of the order of 0.3 volts R.M.S. The rise in the bass is of the order of 10 db., which is approximately the increase required to correct for recording. The armature resonance at 3,600 cycles is 6 db. on open circuit, but would be reduced when using the recommended volume control of 50,000 ohms.

The moulded tone arm is well designed and lifts vertically for needle changing, a spring-loaded catch being arranged to hold it in this position. The price of the unit is 32s. 6d.

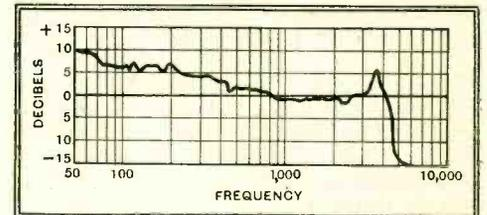

Frequency response of Columbia No. 22 pick-up with Columbia "Talkie" needle.

### CATALOGUES RECEIVED

Varley, 103, Kingsway, London, W.C.2.—Radio components.

General Electric Co., Ltd., Magnet House, Kingsway, London, W.C.2.—Radio receivers.

Baird Television, Ltd., 133, Long Acre, London, W.C.2.—Baird grill cell unit.

Harris and Stern, Ltd., 26, Helmet Row, Old Street, London, E.C.1.—The "Teeback" hacksaw frame.

Lectro Linx, Ltd., 79a, Rochester Row, London, S.W.1.—"Clx" connectors, plugs, sockets, terminals, valve holders, etc.

Pye Radio, Ltd., Africa House, Kingsway, London, W.C.2.—Leaflet describing superheterodyne receivers.

The Peto-Scott Co., Ltd., 77, City Road, London, E.C.1.—Illustrated catalogue of radio cabinets, including containers for loud speakers and radio-gramophones, and also the new Metaplex metal-sprayed baseboards.

Wurlitzer Lyric Radio, Ltd., 33, King Street, Covent Garden, London, W.C.2.—Leaflets describing the Lyric Minor universal midget superheterodyne and the Lyric Cruiser car set.

British Blue Spot Co., Ltd., 94-96, Rosoman Street, Rosebery Avenue, London, E.C.1.—Leaflet describing the Blue Spot Class "B" output stage, complete with loud speaker, for addition to existing receivers.

The Marconiphone Company, Ltd., 210, Tottenham Court Road, London, W.1.—New descriptive folder dealing with Marconiphone receivers and radio-gramophones.

# Television Explained

## V—Mechanical Scanning Systems

**T**HE action of the simplest form of mechanical scanning, the Nipkow disc, has already been dealt with; there are, however, many alternatives which find considerable use in modern television equipment. Undoubtedly, the chief of these is the mirror-drum. The Nipkow disc is replaced at transmitter or receiver, or both, by a

were made the same, the result would be the appearance of a single vertical line of light upon the viewing screen. Each mirror, however, is mounted at a slightly different angle, so that the light reflected from the first causes the light spot to traverse a line at the extreme edge of the screen, the light from the second mirror a line immediately adjacent to this, and so on, until the last mirror gives rise to a line at the other edge of the screen. The whole process is then repeated.

***M**ECCHANICAL scanning methods are not confined to the Nipkow disc, and alternatives such as the mirror drum are often employed successfully. In this article a description is given of the chief systems which are now used or which are interesting from a technical standpoint.*

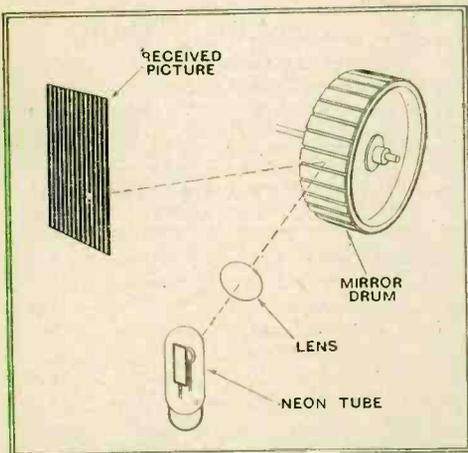

Fig. 1.—Mirror drum apparatus is here depicted diagrammatically. The drum rotates at high speed and each mirror is set at a slightly different angle.

drum the periphery of which carries a series of small mirrors; there is one mirror for every scanning line required, and the mirrors are all identical save for their angle of attachment to the drum.

The arrangement of the receiver is depicted in Fig. 1. The light from the neon tube passes through an optical system for focusing purposes and falls upon one of the mirrors on the drum. It is then reflected on to the viewing screen, and it will be readily appreciated that the precise point on the screen upon which it falls will depend upon the precise angle of the mirror in two planes. The position of the spot on the screen in a horizontal direction depends upon the angle of the mirror relative to the axis of the drum, assuming the neon tube and screen to be correctly placed. The vertical position, however, depends upon the angular displacement of the mirror around the circumference of the drum.

The drum is rotating, so that the spot of light moves across the screen in a vertical direction. If the angle of each mirror

### Vibrating Mirror System

The process achieves the same result as the Nipkow disc, and it has the merit of greater optical efficiency, provided that suitable mirrors are used. There are many variations in practice, and the drum does not necessarily take the form shown in Fig. 1. This is the usual form, certainly, but a modification has been derived in Germany which has the merit of occupying far less space. It is usually known as the mirror screw, and its operation will be seen from the photograph on this page, which is self-explanatory when it is remembered that the screw is rotating about its axis, and that the scanning is carried out horizontally in accordance with the usual practice outside the British Isles.

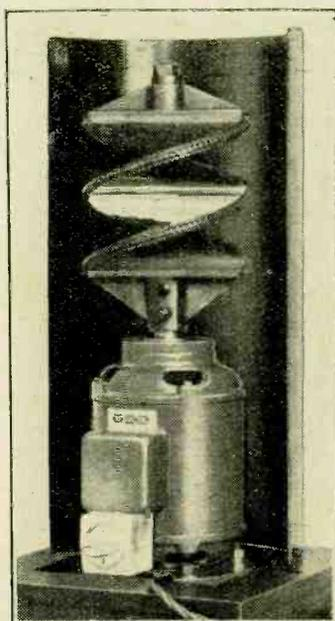

The Tekade mirror-screw employed in Germany.

Other arrangements of mirrors have been tried out, of which the most important is perhaps that employing oscillating mirrors instead of rotating arrangements. This is shown in Fig. 2, and it will be seen that the mirror E oscillates rapidly about its axis AB, while the mirror F oscillates slowly about an axis CD at right angles to that of the former. The beam of light GH from the neon tube falls upon the mirror E, and is reflected from it along the line HI. Now, the angle between GH and HI depends upon the angle between GH and the surface of the mirror, and is just double the latter angle. Since the mirror is oscillating, the angle between GH and HI is continually altering, and the result is to cause the point I where the beam HI impinges upon the surface of the mirror F to move in a vertical direction.

This mirror F, however, is also oscillating about the axis CD, so that the angle between HI and IJ is changing. The

result of the oscillations of both mirrors is to cause the spot of light on the viewing screen to move both vertically and horizontally. The oscillation of mirror E makes the spot move vertically, and that of mirror F gives a horizontal deflection. The oscillation of the former, therefore, is rapid, and gives the scanning lines, while the slowed oscillation of mirror F results in successive lines being correctly displaced sideways.

So far, this system has not proved of great service, for synchronisation of the oscillation frequencies of the mirrors proves far more difficult than in the case of a simple rotating disc or drum. From a theoretical standpoint, however, it is undoubtedly attractive.

### Mechanical Difficulties

With the present 30-lines transmissions mechanical methods of reception can be entirely satisfactory, but it is doubtful whether they can provide the necessary accuracy for the domestic reception of higher grade pictures. Assuming that some form of rotating mirror drum be used, an increase in the number of scanning lines means an increase in the size of the drum. This, in turn, means increased weight, which carries with it the necessity for a more powerful driving motor and greater difficulty of synchronisation. An increase in the number of pictures a second, which is also desirable, means an increase in the

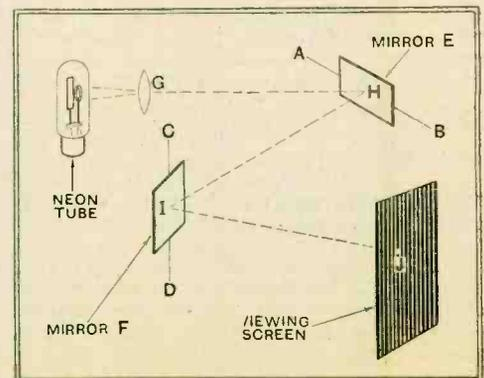
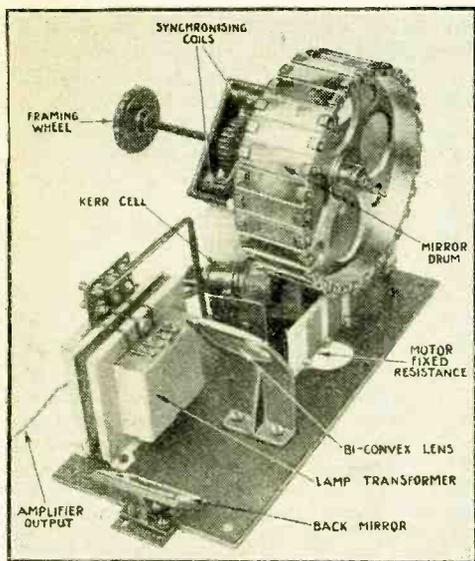

Fig. 2.—A system of scanning involving vibrating mirrors. The action is explained in the text.

## Television Explained—

speed of rotation of the drum, which introduces further difficulties. It is, of course, quite possible to use a mirror-drum for 120-line transmissions with twenty-five pictures a second, and good quality pictures have been transmitted in this way. Although these pictures could doubtless be received with the aid of a similar drum, its dimensions and the type of motor required to drive it are unlikely to commend themselves for domestic reception, and it is the usual practice, therefore, to abandon mechanical methods for high-quality picture reception, although they may still be employed in transmission. The cathode-ray tube is becoming more and more applied to television reception, and it appears likely to displace mechanical methods entirely.



The arrangement of parts in mirror drum equipment. In this particular case a Kerr cell is used, to modulate a source of light, instead of a neon tube.

Apart from the space required to accommodate the mirror drum and its driving motor, it is a matter of considerable difficulty to obtain completely silent operation, and the whine of the motor can become troublesome. Moreover, cabinet work has to be extremely rigid if the vibration is not to affect the operation. None of these difficulties is apparent with the cathode-ray system, for the arrangement is entirely electrical. The questions involved, therefore, will be considered in some detail in the next article.

## Radio Amateur Call Book

TRANSMITTERS and short-wave listeners will welcome the autumn edition of this semi-official list of all known amateur transmitting stations of the world. Each succeeding issue is bulkier than the last, and in itself provides good evidence that interest in short-wave working among amateurs is not waning.

It is perhaps a matter for regret that some of the supplementary information has had to be slightly curtailed, but the useful list of Commercial High Frequency Stations is considerably enlarged so that for all practical purposes the book in its growth retains all the particulars likely to be required by its users.

Copies may be obtained in Great Britain from Mr. F. T. Carter, Flat A, Gleneagle Mansions, Streatham, London, S.W.16. Price 6s. 6d. for a single copy, or 21s. for the year.

## DISTANT RECEPTION NOTES

## Is Fading on the Decline?

A WEEK or two ago I mentioned that owing to the strength at which both Stuttgart and Munich were being received it was difficult to believe that the old low-power transmitter was in use in either case. Both stations still continue to provide first-rate reception. Munich has come in at full loud speaker strength whenever I have tried for it recently, whilst Stuttgart is readily separable—sideband splash excepted—from the London Regional. Were Stuttgart working with an output of only 1.5 kilowatts the selectivity of the set would have to be such that the London Regional was thousands of times "down" only 11 kilocycles off resonance.

Though I have not heard announcements to the effect, I think that the new Tegel station of Berlin Witzleben must be conducting test transmissions on comparatively small power. I have heard Berlin on 419 metres several times during the past week, but not yet at enormous strength.

There is extraordinarily little fading at the moment on the medium waveband, and what there is is of very mild type. With A.V.C. it is completely eliminated, and even without A.V.C. it is seldom bad enough to be at all troublesome.

## Ten-fold Power Increase

Transatlantic reception is extraordinarily good when conditions are at all favourable. As I predicted some time ago, American stations on wavelengths above 350 metres are now beginning to come in very well. Amongst stations frequently logged during the past few weeks are WGY (379.5 metres), WJZ (394.5 metres), and WLW (428.3 metres).

WLW, by the way, is still transmitting with 50 kilowatts in the aerial, but it will not be long before ten times this power is used in experimental transmissions from the new plant.

On the long waveband Luxembourg is again badly heterodyned and Kalundborg is occasionally affected. Oslo on one recent evening was almost blotted out by continuous-wave morse signals. Huizen is sometimes completely free of the interference that has been troublesome for so long, and when this is the case first-rate reception is assured. Radio-Paris, Zeesen and Warsaw are all reliable stations, and Motala is generally to be heard.

Some very fine transmissions are to be heard at the top of the medium waveband. Budapest is now in splendid form, whilst Munich, Vienna, Brussels No. 1 and Florence seldom fail to provide full loud speaker volume. Prague is usually very good, but has been varying a little. Langenberg and Lyons Doua are reliable. Beromünster is again heterodyned in the evening, though generally well received in the afternoon. Rome lives up to its reputation as one of the best of European stations and Stockholm is often almost as good.

For some reason Katowice is not so well heard now as it was some weeks ago. Toulouse is invariably a good signal, and Madrid Union Radio is to be heard once more.

Leipzig is strong and reliable. Hamburg varies greatly from night to night, being sometimes excellent and sometimes quite faint. Strasbourg, Brussels No. 2, Milan, Poste Parisien and Breslau are generally

reliable, though Milan and the Poste Parisien are occasionally heterodyned. Brno makes only rare appearances in the log, but when it is received it is always at good strength. Bratislava is badly interfered with, but Hilversum and Heilsberg come through excellently. Turin is generally a good signal and Frankfurt is always worth attention. Trieste, Nürnberg and Fécamp are well heard in the lower part of the medium waveband, whilst both Toulouse PTT and Hörby provide occasional good reception.

D. EXER.

## An Interesting Exhibit

VISITORS to the various Radio Exhibitions which have been held during recent months have been afforded a unique opportunity of examining modern methods of loud speaker construction and assembly in the sectionalised models exhibited by Reproducers and Amplifiers, Ltd., of Wolverhampton. The skill with

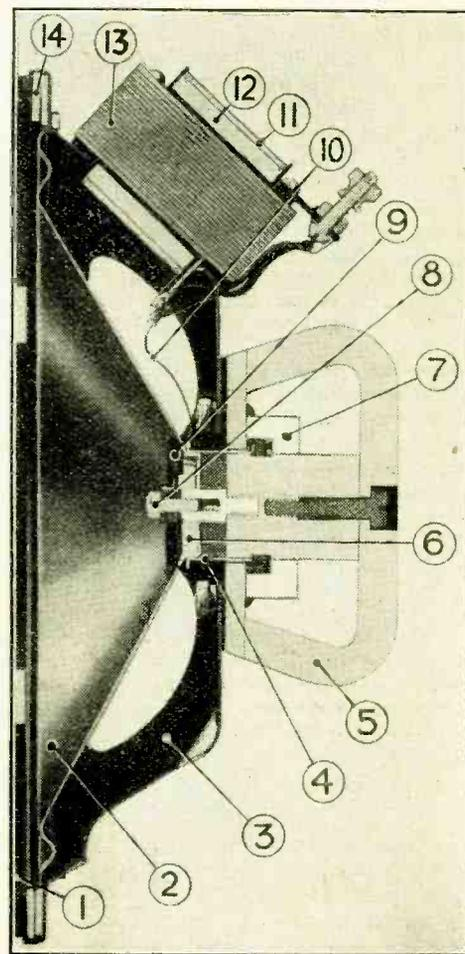

Sectional model of the R. & A. "Challenger" moving-coil loud speaker. The component parts are as follows:—1, baffle felt; 2, diaphragm; 3, chassis; 4, speech coil; 5, magnet; 6, speech coil pressure ring; 7, speech coil dust excluding washer; 8, spider locking screw; 9, centring spider; 10, speech coil lead; 11, transformer secondary winding; 12, transformer primary winding; 13, transformer core; 14, diaphragm clamping section.

which the smallest screws, and even the transformer windings, have been sectioned is a wonderful example of the instrument makers' art, and the function of every component part can be clearly seen.

Letters to the Editor:—

# Speaker Response Curves

## High Quality: Valves or Stages: Output Control: Disc Records

The Editor does not hold himself responsible for the opinions of his correspondents

### Speaker Response Curves

WHILE no doubt the majority of the readers of *The Wireless World* are familiar with an ordinary curve, I think it should be clearly emphasised that the interpretation of a loud speaker response curve is very different from that of a curve correlating two specific electrical functions.

Whereas the general level and shape of a transformer response curve, for example, gives a visual indication of the true performance of the transformer, the general shape of a speaker response curve is not necessarily an indication of its actual performance, and the curve requires careful interpretation.

Investigation of the response of any loud speaker reveals that the relative difference in output at two very near frequencies is quite appreciable. Actually, if one requires a very accurate indication of the speaker performance it is necessary to plot an exceptionally large number of points, and these points should preferably be plotted at random frequencies where it is noticed that marked deviations in the output arise. If, say, 80 to 100 points are taken, these can then be joined by a substantially curved line, and one obtains a very good approximation of the general nature of the response of a speaker.

When investigating speaker responses in a general manner it is customary to plot only quite a small number of points, perhaps some thirty to forty, and it is then general to join these by a straight line. The resulting "curve" indicates at its various peaks the relative output at the frequencies at which the points were taken. This curve indicates the general nature of the relative response, but obviously it gives no indication of the response on the various straight portions, that is, between the points at which the output has been measured.

Both types of curve are in general use, and they each serve their specific purpose, and accordingly it seems to me very desirable that the lay reader should appreciate the significance of each type so that he may draw his own conclusions when studying a response curve.

It should also be realised that response curves are taken by measuring the output of a capacity microphone when the speaker is energised by a sine wave. Should, however, the speaker introduce frequency doubling or other wave form distortion no indication of this is given by the curve, which is obtained by plotting the amplified microphone voltage, which in many cases is of unknown wave form. The actual performance of a speaker can, therefore, only be obtained by simultaneous oscillograph examination, or, alternatively, some electrical system of wave form distortion or harmonic analysis.

Finally, it must be remembered that these measurements are made under static conditions and the curve given by a microphone output is no criterion of the ability of a speaker to deal with transients which have such a marked bearing upon the all-import-

ant question of attack. Accordingly, the speaker response curve to my mind should be regarded only as a "pointer" rather than a graphic delineation of electrical and acoustic constants.

Watford. PAUL D. TYERS.

### "Mystery" Station

WITH reference to the controversy with regard to the "Mystery" station causing so much trouble with Huizen transmissions, may I respectfully state that this is most definitely not a Rumanian station?

After Huizen has closed down, I have, on many occasions, picked up the interfering station, which, at all times, has been radiating a sort of inter-station discussion in Russian, in common with other Soviet transmitters. There is no Rumanian station using Russian, and this is definitely a Soviet station.

LEOPOLD FRIEDMAN.  
Edgware, Middlesex.

### High Quality

A HIGH quality receiver should respond similarly to the modulation of signals of all wavelengths in a given waveband.

The *Wireless World* Autotone (which was described in theory and in practical form in issues published at the end of 1931 and beginning of 1932) is the only receiver that theoretically fulfils this condition.

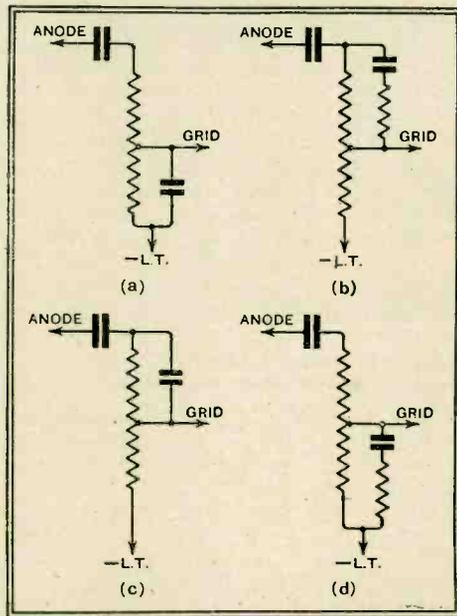

(a) To reduce treble; (b) to reduce bass; (c) to increase treble; (d) to increase bass.

To preserve transients, transformers and any inductive L.F. coupling must be avoided. This means that a sharp cut-off in the L.F. circuits to remove heterodynes

Correspondence, which should be as brief as possible, should be addressed to the Editor, "The Wireless World," Dorset House, Stamford Street, S.E.1, and must be accompanied by the writer's name and address

is not possible. However, a large degree of tone correction can be obtained with R.C. couplings in suitable combinations as shown in the figure.

To obtain a sharp cut-off at the top of the spectrum, I suggest arranging for a peak separation in two I.F. transformers of 10 kc/s or more according to conditions and requirements. Further, I suggest using a valve to provide reaction on the single H.F. circuit to provide the necessary selectivity.

By means of mechanical arrangements similar to those used in the Autotone, the H.F. resistance of this signal tuned circuit can be kept constant at a low value throughout the waveband, though, of course, not so low as in the Autotone. By this means a straight line L.F. response can be obtained throughout the waveband.

F. L. INGRAM.  
Kingston-on-Thames.

### Output

I HAVE just read with interest the letter by "Lead-in" on output. On reading the last sentence, stating that the example is a strong argument for the use of a double output stage when separate high- and low-note speakers are used, I am led to believe that the writer himself does not see where the "obvious" fallacy lies.

When 25 volts peak of f1 and 25 volts peak of f2 are together applied to the grids loading them with 50 volts peak the output will be 8 watts, and not 4 watts, as stated. For this reason "Lead-in" has not made me decide to fit a double output stage to feed my speakers, which are of the type mentioned.

H. GRAYSON.  
Manchester.

### Valves or Stages?

WHILE the system of describing a wireless receiver by its number of stages is perhaps better than the number of valves system, it is by no means ideal, for as pointed out in the letter from Mr. G. A. Taylor in your issue of September 30th, an A.V.C. diode can be counted as a stage without improving the receiver from the point of view of range.

The layman buying a receiver wants an indication of the volume of sound a receiver will produce when operating on a given station, or, alternatively, an indication of the number of stations that can be received at a given volume. Hitherto with a straight battery-driven set the number of valves could be taken as a rough guide, but with modern developments such a procedure is liable to be misleading.

The ideal method would be to describe a receiver by its overall amplification. Since the actual amplification obtained will depend on the efficiency of the circuits in addition to the valves the actual amplification could not be readily checked, and misrepresentation would be possible. To avoid this the figure obtained by multiplying together the amplification factors of all the valves which contribute to the over-

all magnification of the set could be used. This figure could be easily checked from the valve makers' catalogues. Since this figure would run into millions a unit consisting of a million magnifications could be devised.

This system would be similar to the horse-power method of rating cars.  
Plumstead. W. HARMER.

THE letter from R. J. Cotterswood in your issue for October 27th seems to deal very thoroughly with the question of how receivers shall be designated, and, whilst his suggestions would probably be ideal and indicate pretty clearly the performance of receivers, it is unfortunate that, speaking from the general commercial point of view, the ladies are mainly responsible for choice of wireless sets, and their choice is very largely in the direction of pretty-pretty cabinets, to the exclusion of what may be inside, and, until such time, if ever, that they develop a real interest and intelligence as to what is inside, the question of a precise specification is not of much importance, although, as I explained in my original letter, I consider this should always be included in the technical details of the set, which should be as full as possible, but which are really understood by a very tiny minority.

of the electron stream, a thing which, in these days of bigger and better electrons, should be unheard of.  
J. BAGGS  
Manchester.

#### Output Control

THE complaint regarding the annoying activities of the B.B.C. output control engineers during organ broadcasts appears in your Correspondence columns at an opportune moment. Whatever reasons might be advanced in favour of exercising this control in the case of "outside" broadcasts, it is difficult to understand how it can be justified in connection with the B.B.C.'s own organ. This instrument exists solely for broadcasting purposes, and was designed in every detail with this end in view.

On September 10th, during a broadcast intended to demonstrate the various features of this organ, the softest stop and the full power of the instrument were shown in contrast—at least, this is what was intended. The desired effect was, however, frustrated by the control engineer, who, having increased the power of the softest stop so that the listener had no idea of its relative softness, had to "cut down" the volume of the full organ to a much lower level—a fraction of a second too late, however.

This kind of thing naturally is most an-

must be negligible compared with the cost of pressing records.

(3) Is it not a fact that the day of the cheap acoustic gramophone has now passed for ever, especially having regard to the comparatively cheap and efficient electrical reproducer?

(4) Why should Flight-Lieut. King, or, indeed, anyone else, go to the expense of purchasing a two turntable unit when a better reproducer could be made commercially by the use of "film"?

(5) I agree that the Gramophone Company have done very much indeed in furthering the cause of good music, but will the Company give unequivocal answers to Flight-Lieut. King's questions, viz.:

(a) Why have not the gramophone companies produced an instrument on the lines suggested?

And  
(b) Are the gramophone companies afraid that they are going to lose money on scrapping the existing equipment?

I think the answers would be interesting.  
London, S.E.23. J. L. CARDEN.

### CLUB NEWS

#### D.F. at Sea

Actual experiences of direction finding at sea were related by Mr. Rapsey in his lecture on direction and position finding by the Bellini-Tosi system, at a meeting of the Southall Radio Society. Hon. Secretary: Mr. A. J. Stephens, 98, Pole Hill Road, Hillingdon.

#### Straight Set Wins

Two to one in favour of the straight set was the outcome of the voting after a hard-hitting debate on "Superhet v. Straight Set" at a recent meeting of Slade Radio (Birmingham). The annual general meeting is to be held on November 30th, 8 p.m., at the Parochial Hall, Broomfield Road, Erdington. Hon. Secretary: 110, Hillaries Road, Gravelly Hill, Birmingham.

#### Improving Quality

A demonstration of "Correcting Bass Response in Gramophone Reproduction" will be given by Mr. A. H. Pratt at the meeting of the Exeter and District Wireless Society, at 8 p.m., on Monday next, November 27th. Hon. Secretary: Mr. W. J. Ching, 9, Sivel Place, Heavitree.

#### The Acid Test

Fourteen loud speakers were put on trial at this season's first joint meeting of the Croydon and Thornton Heath Radio Societies. A home-made valve oscillator giving frequencies between approximately 75 to 6,000 cycles was used to discover bad resonances. On Tuesday next, November 28th, the Croydon Society will hold its short-wave night. Hon. Secretary: Mr. E. L. Cumbers, 14, Campden Road, South Croydon.

#### Demonstrating Exponential Horns

"Exponential Horn Loud Speakers and Quality" is the title of a lecture to be given by Mr. E. Mewse, M.Sc., at the meeting on Monday next, November 27th, of the Newcastle-upon-Tyne Radio Society, in the Church Hall, Armstrong Bridge, Jesmond. Hon. Secretary: Mr. W. W. Pope, 9, Kimberley Gardens, Jesmond.

#### Bargains!

The Edinburgh and District Radio Society will hold an auction sale on Thursday next, November 30th. Full particulars are obtainable from the Hon. Secretary, Mr. W. Winkler, 13, Lockharton Crescent, Edinburgh.

#### Ratepayers' Radio

The theory of the detector valve and of transformers will be dealt with by the New Eltham Ratepayers' Association, Radio Section, on November 30th. Meetings are held on alternate Thursdays at 8 p.m., at the Bungalow in the grounds of The Beehive Hotel, Footscray Road, Eltham. Hon. Secretary: Mr. A. E. Gillborn, 87, Montbelle Road, New Eltham, S.E.9.

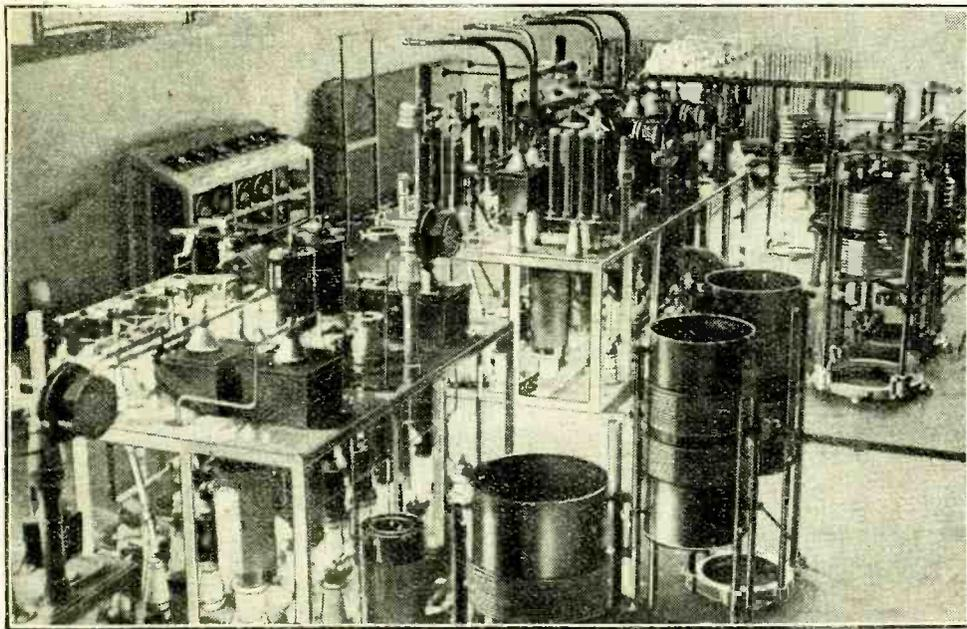

GERMANY'S LATEST. The new 100 kW. station or "Grossrundfunksender" at Tegel near Berlin, is already testing. Above is a view of the output stages of the transmitter.

My main objection to the specification of stages was the difficulty in being quite clear as to the definition of a stage, since, for example, in a superheterodyne receiver if the oscillator portion consists of a stage it is just as logical for the A.C. rectifier to be included as a stage as well, or possibly the oscillator and first detector might be combined as one stage, in which case, of course, they line up with the valve position in those sets which employ a combined oscillator-modulator, such as the Heptode.

On the other hand, the number of valves in a set is a thing that can readily be seen, whereas the specification of stages leaves the matter open to endless wangling, which is, perhaps, more common to the radio industry than any other.

In conclusion, I should like to apologise most humbly to "Free Grid," and also to your aforementioned correspondent, for having inadvertently reversed the direction

noying to listeners, and it is time something was done to check such unwarrantable interference with the effects aimed at by broadcast performers.

VERNON C. COOMBS.

Bromley, Kent.

#### Alternatives to the Disc Record

I HAVE followed this correspondence with great interest, and I am surprised at the very unsatisfactory reply of the Gramophone Company, Ltd., to Flight-Lieut. Patrick King's letter.

To take the points in order:—

(1) I fear that the Gramophone Company has not read *The Wireless World* very carefully, otherwise such an article as "Synthetic Sound"—issue of February 3rd, 1933—would undoubtedly have given a very broad hint. Upon what scientific grounds is a paper "film" impracticable?

(2) The cost of printing paper "films"

# The Faraday All-wave Superheterodyne S. 620L

Incorporating A.V.C.

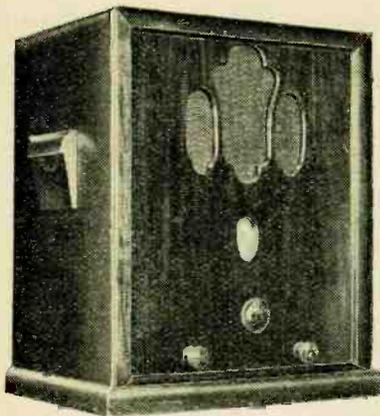

**FEATURES.** *Type.*—Table model superheterodyne receiver for A.C. mains, covering wavelengths from 15-2,000 metres. Includes automatic volume control and a moving-coil loud speaker. *Circuit.*—Var.-mu H.F. pentode signal frequency amplifier—H.F. pentode frequency changer—var.-mu H.F. pentode I.F. stage—duo-diode pentode second detector—pentode output valve. *Controls.*—(1) Tuning calibration on all four wave-ranges. (2) Wave-range switch. (3) Volume and on-off switch. (4) Tone control switch. *Price.*—In walnut cabinet, £28 10s. *Makers.*—Faraday All-wave Wireless, 1, Salcott Road, London, S.W.11.

from Bound Brook was sufficient to actuate the automatic volume control, so that the background noise was reduced to a negligible level except during one or two intervals of severe fading. The manual volume control could not be increased to beyond the mid-position without overloading.

Although tuning is of necessity sharp on the short-wave stations, the stability of the circuit, even on an indifferent earth system, is above criticism, while accurate calibration on the short wavelengths is a feature which is all too rare in sets of this type.

Having successfully solved the problems presented by the short wavelengths, it is only to be expected that the designers would provide a good medium and long wave performance. Twenty-three stations

**E**XTERNALLY the chassis is very little different in appearance from last year's model, which was reviewed in our issue dated October 28th, 1932, but several alterations have been made in the circuit which have resulted in improved performance.

Full advantage has been taken of the latest types of valves, and a duo-diode pentode has been employed in the second detector stage to give automatic volume control, which is of the greatest possible value when receiving short-wave stations which are subject to fading. Variable-mu H.F. pentodes are used in the H.F. and I.F. stages, which are both controlled on the medium- and long-wave bands. On short waves the signal frequency H.F. stage is running at full magnification, and the control is confined to the I.F. amplifier.

The frequency changer circuit is interesting. The valve used is an ordinary H.F. pentode, and the cathode, working grid and screen grid are used as the three electrodes of a modified Hartley oscillator. The anode is given a slightly higher potential than the screen grid, and the coupling to the I.F. circuit is made *via* the electron stream from screen grid to anode. This gives a very stable and efficient circuit, which is admirably suited to short-wave conditions.

On medium and long waves the anode circuit of the signal frequency amplifier stage is tuned to the incoming signal, the coupling to the oscillator circuit being effected by resistances common to both circuits. On short waves, however, the anode is connected directly to the oscillator circuit. An aerial trimmer is provided, and the necessary adjustment is facilitated by connecting a voltmeter across the resistance providing the minimum bias for the variable-mu H.F. and I.F. valves. The second detector and A.V.C. circuits follow accepted practice,

and a measure of tone control is introduced at this point by switching a small fixed condenser across the load resistance.

The performance on short waves naturally received first attention, and it is safe to say that the sensitivity and overall mag-

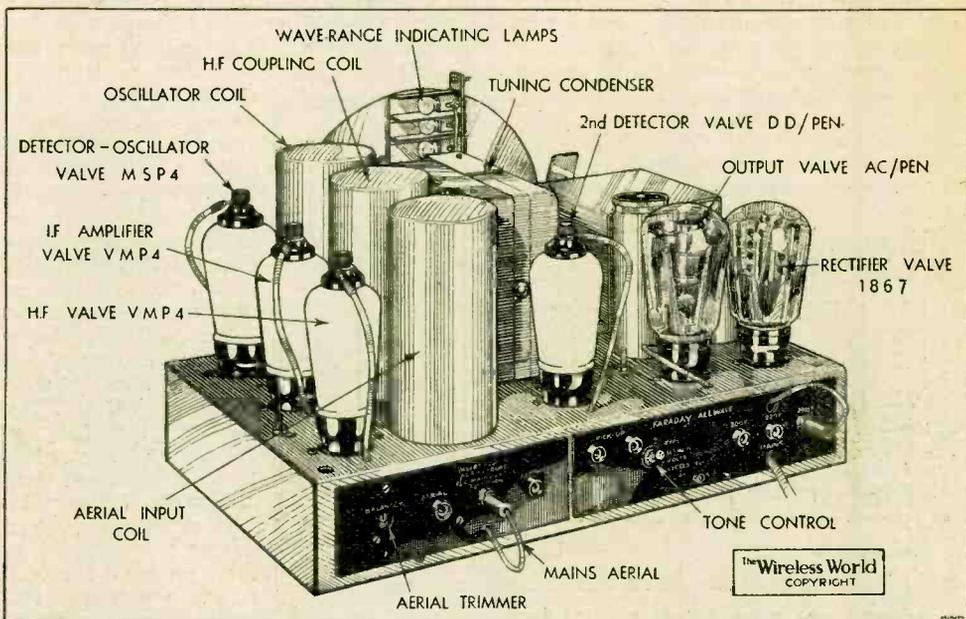

Although radical changes have been made in the design of the circuit, the appearance of the chassis differs little from last year's model.

nification would impress the most experienced short-wave enthusiast. At the time of our tests the 15-30 metre band gave best results, and Pittsburgh, W8XK, and Bound Brook, W3XAL, were well received in daylight during the afternoon. Although the receiver was installed in Central London near a busy thoroughfare and a certain amount of interference from car ignition systems was experienced, the signal strength

were, in fact, logged on the medium wave-band in daylight, and the selectivity was sufficient to give adjacent channel separation on all stations with the exception of the local transmitters, where one channel on either side was lost.

A very full instruction booklet, containing useful information on short-wave conditions in general, and a wiring blue print is issued with each set.

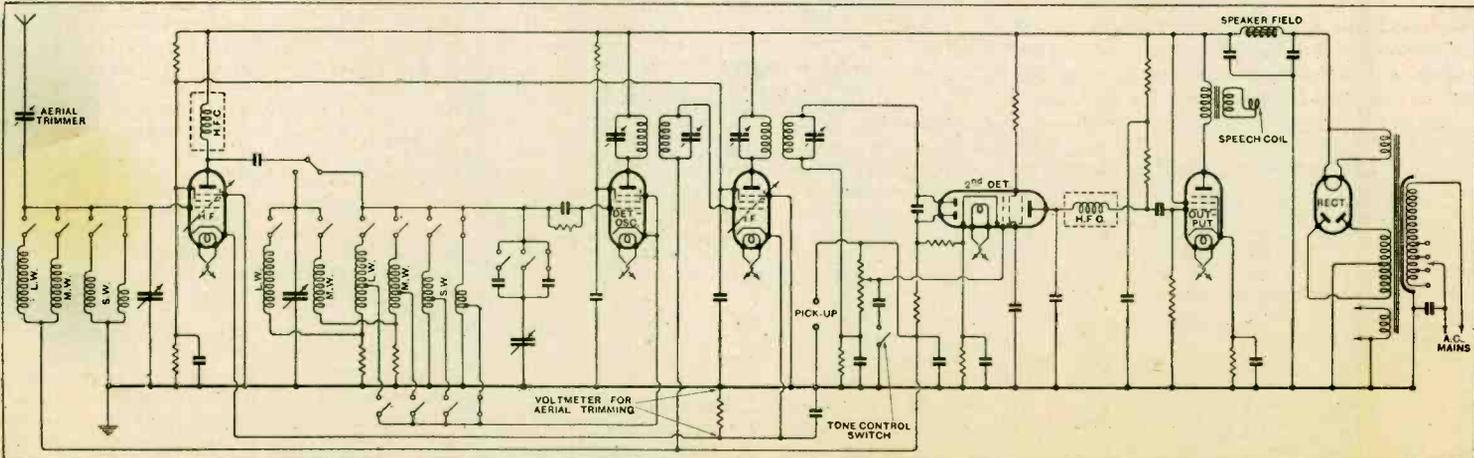

Complete circuit diagram. An H.F. pentode frequency changer and a duo-diode pentode second detector are features of the circuit in its latest form.

# READERS' PROBLEMS

## Grid Return Leads

THE fitting of A.V.C. to existing receivers (especially to those of the super-heterodyne type) becomes easier and easier, but it would seem that many constructors are still uncertain as to the precise nature of the slight alteration that must be made in the grid circuit of the controlled valve (or valves).

These difficulties will generally disappear if it is realised clearly what we have to do. Put as simply and briefly as possible, the grid return leads of the controlled valves must be disconnected from the original source of fixed or manually-regulated bias, and then reconnected to the source of A.V.C. voltage in order that the operating bias may be varied automatically in sympathy with the strength of incoming carrier waves. In addition, decoupling will generally be needed.

With regard to the simplest type of mains-

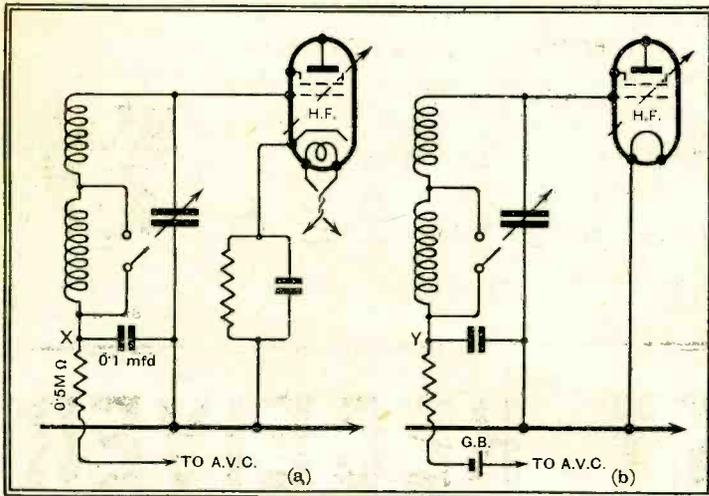

Fig. 1. When A.V.C. is added, slight alterations in the grid return circuits of "controlled" valves are usually needed.

operated set, all that will have to be done in the way of disconnection is to take off the lead joining the low-potential end of the grid coil from the earth line or metal chassis. This point, which is marked X in Fig. 1 (a), is now joined to the source of A.V.C. voltage through a decoupling resistance, the associated by-pass condenser being added to "tie down" the circuit so far as H.F. impulses are concerned.

In battery sets (Fig. 1 (b)) the procedure is basically the same. The low-potential end of the grid coil (marked Y in this diagram) was probably joined originally to earth through a bias cell, which should now be disconnected and then replaced on the other side of the decoupling resistance as shown.

## Class "B" Pitfalls

IT has been proved that a properly designed Class "B" amplifier is capable of giving very pleasing quality; a good deal of space has lately been devoted in these pages to the eradication of the minor difficulties that are likely to prevent the attainment of good results.

A querist who has tried all the usual cures for distortion, but without success, now solicits our help: his circuit arrangement is correct, but he is using a driver transformer of unknown make.

Although this component may be satis-

factory, it seems very likely that it is responsible for poor quality. It should be emphasised that the design of such transformers is by no means a simple matter, and that satisfactory specimens are only produced by firms who have devoted a good deal of thought to the subject.

## Keep it Carefully

A CORRESPONDENT is using an eliminator rated to give 30 milliamps. at 150 volts. The H.F. and detector valves of his receiver consume between them 10 milliamps., leaving 20 milliamps. for the output valve.

What we are asked to do is to suggest a suitable 3 - electrode battery-operated output valve which will absorb the available 20 milliamps.

We sincerely hope that our correspondent has not already mislaid the Valve Data Booklet, included in our issue of November 3rd! A glance at that invaluable little publication will show that almost every manufacturer produces a 2-volt valve requiring between 18 and 20 milliamps.; there are so many excellent specimens that we can hardly draw invidious comparisons.

## Where Losses are Unimportant

A QUERIST, who is not completely satisfied with the sensitivity of his newly built receiver, asks whether it is possible that efficiency could be improved by replacing the present reaction condenser, which has bakelite dielectric between the vanes, by one of the air-dielectric type.

As compared with air, it is certain that

## The Wireless World INFORMATION BUREAU

THE service is intended primarily for readers meeting with difficulties in the construction, adjustment, operation, or maintenance of wireless receivers described in *The Wireless World*, or those of commercial design which from time to time are reviewed in the pages of *The Wireless World*. Every endeavour will be made to deal with queries on all wireless matters, provided that they are of such a nature that they can be dealt with satisfactorily in a letter.

Communications should be addressed to *The Wireless World* Information Bureau, Dorset House, Stamford Street, London, S.E.1, and must be accompanied by a remittance of 5s. to cover the cost of the service. The enquirer's name and address should be written in block letters at the top of all communications.

any solid dielectric material in common use is bound to introduce considerably higher losses. But in a reaction circuit it is most unlikely that these losses will have any prejudicial effect on sensitivity or selectivity. It is therefore suggested that, if self-oscillation can be brought about at all wavelengths, it is hardly worth while to make a change. Probably some other part of the receiver is susceptible to improvement.

## Diode Potentiometer

IT is worth while pointing out that, with diode detection, there is no better method of obtaining post-detection volume control than by using a potentiometer (in place of a plain resistance) as the diode output load. Any desired proportion of the rectified voltage developed across this load may then be applied to the succeeding L.F. amplifier in the simplest possible manner, and without risk of introducing distortion.

These remarks are prompted by letters from two or three readers who have proposed unnecessarily complicated—and sometimes rather ineffective—methods of L.F. volume control in sets where diode rectification is employed. The same applies to receivers employing a Westector, which is in many ways comparable with a diode valve.

## High-output Battery Amplifier

ALTHOUGH the undistorted output obtainable from the Class "B" system is enormous when judged by previous standards set for battery valves, it still falls short of that required in many instances for public address work. But by the use of two of the new valves in parallel it should be possible to obtain sufficient volume for many purposes without overtaxing the capabilities of a good high-capacity dry battery.

This subject is raised by a reader who asks for information on the "paralleling" of Class "B" valves. It seems probable that, even with a specially designed driver transformer, it would be extremely risky to connect merely the output valves in parallel in the obvious manner; apart from other difficulties, parasitic oscillation would probably occur. It is therefore recommended that both the driver and output valves

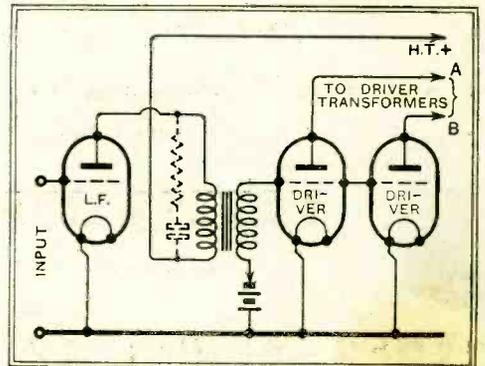
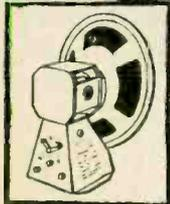
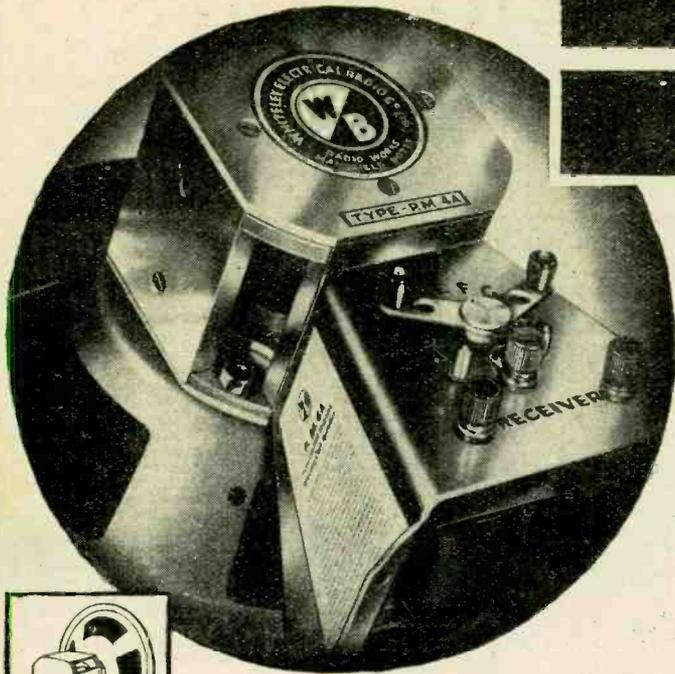

Fig. 2.—Duplicated Class "B" amplifier with exceptional power output. From points A and B onwards the separate output valve circuits are independent.

should be duplicated; thus, two driver valves, two driver transformers, and two output valves, each feeding separate speakers, will be needed. The drivers will be connected as in Fig. 2, with their grids joined together. As the driver valve is a purely voltage-operated device and consumes no power, several may be "paralleled."



17 Ratios for power or pentode: 4 for Class B give perfect matching. The Mansfield magnet gives greater sensitivity.

# HOW MANY LISTENERS REALISE?

Extract from "Wireless World."

"... and a choice of seventeen ratios is available for single output valves and four ratios for push-pull stages requiring a centre tap. The change both in volume and quality, on varying the step-down ratio, is most marked, and the load can be rapidly adjusted to give the best results. Tested with the load adjusted to the calculated value, the efficiency was found to be exceptionally good for a permanent-magnet unit. Above 100 cycles it was equal to that of our standard 10 in. energised unit. The PM4A is also remarkable for the excellent response at the extreme top. Between 7,000 and 9,000 cycles it has a better output than any small commercial unit so far tested."

A user writes:

"I wonder how many listeners realise (as I did when trying out the 'Microlode' pointer) how much volume is wasted when the speaker is not correctly matched to the output valve."



'Microlode' Model PM4A **42/-**

'Microlode' Model PM6 **32/6**

Whiteley Electrical Radio Co. Ltd., Dept. W, Radio Works, Mansfield, Notts.  
Sole Agents in Scotland: Radiovision Ltd., 233 St. Vincent St., Glasgow, C.2.      Sole Agents in I.F.S.: Kelly and Shiel, Ltd., 47 Fleet St., Dublin.

# HAYNES QUALITY RECEIVER

RECOGNISED AS THE SET FOR THE CONNOISSEUR.

Embodying all the latest and best practice.

Band pass aerial coupling preceding H.F. stage using variable-mu pentode H.F. valve (seven-pin V.M.P.4). High voltage power grid detection with unique arrangement of grid voltage control giving particularly smooth reaction adjustment, three Ferrocart tuned circuits, two resistance-coupled L.F. stages, all resistances wire-wound. Generous mains equipment, optional single or dual loud speakers, high voltage 6-watt output stage, two unit construction, all components and pressed metal base plates finished blue-grey cellulose, the exclusive Haynes feature.

Only those components are used which are known to be the best.

KIT £21.0.0. ASSEMBLED CHASSIS £22.15.0. RADIO GRAMOPHONE £37.10.0  
Complete with valves and loud speaker. Dual speakers 30/- extra.

## HAYNES SUPERHETERODYNES, A.C. & D.C.,

Ferrocart coils, H.F. Pentode, amplified delayed A.V.C.

## HAYNES FERROCART THREE and CLASS B RECEIVERS.

Write for "HAYNES RADIO DESIGNS," free and post free.

### DEMONSTRATION NIGHT

Every Friday, 7.30 to 9.30 p.m.  
at the Enfield Factory, Queensway, Ponders End,  
Enfield Town or Enfield Chase Stations, and thence  
by bus or tram.

**HAYNES**  
RADIO

57, HATTON GARDEN,  
LONDON, E.C.1.  
Chancery 8023  
Factory: Queensway, Enfield.

NOW. HAYNES METAL BASE PLATES FOR  
"WIRELESS WORLD" SETS.

TUNER UNIT 15/-, AMPLIFIER UNIT 10/-  
Complete with screws and grommets for the  
"WIRELESS WORLD" A.V.C. STRAIGHT FOUR  
A.C. RECEIVER.

# MISCELLANEOUS ADVERTISEMENTS

## NOTICES.

**THE CHARGE FOR ADVERTISEMENTS** in these columns is

12 words or less, 3/- and 3d. for every additional word.

Each paragraph is charged separately and name and address must be counted.

**SERIES DISCOUNTS** are allowed to Trade Advertisers as follows on orders for consecutive insertions, provided a contract is placed in advance, and in the absence of fresh instructions the entire "copy" is repeated from the previous issue: 13 consecutive insertions 5%; 26 consecutive, 10%; 52 consecutive, 15%.

**ADVERTISEMENTS** for these columns are accepted up to **FIRST POST** on **MONDAY MORNING** (previous to date of issue) at the Head Offices of "The Wireless World," Dorset House, Stamford Street, London, S.E.1, or on **SATURDAY MORNING** at the Branch Offices, 19, Hertford Street, Coventry; Guildhall Buildings, Navigation Street, Birmingham, 2; 260, Deansgate, Manchester, 3; 26a, Renfield Street, Glasgow, C.2.

Advertisements that arrive too late for a particular issue will automatically be inserted in the following issue unless accompanied by instructions to the contrary. All advertisements in this section must be strictly prepaid.

The proprietors retain the right to refuse or withdraw advertisements at their discretion.

Postal Orders and Cheques sent in payment for advertisements should be made payable to **ILLIFFE & SONS Ltd.**, and crossed **Notes being untraceable if lost in transit should not be sent as remittances.**

All letters relating to advertisements should quote the number which is printed at the end of each advertisement and the date of the issue in which it appeared.

The proprietors are not responsible for clerical or printers' errors, although every care is taken to avoid mistakes.

## RECEIVERS AND AMPLIFIERS, ETC.

**MILDMAY RADIO EXCHANGE** Offers the Following, sound and perfect and as stated:—

**1933** Brownie 3-valve A.C. Mains Receivers, with valves and in sealed boxes, specification; screen grid, detector, pentode output, in beautiful figured walnut cabinet, suitable for A.C. mains 200-250 volts; £6/10 each, original list price £15/15; special terms to trade.

**PHONE** Demonstration: Clissold 5001.

**OPEN** Thursday, closed Saturday all day.

**ALL** Carriage Paid.

**24,** Mildmay Grove, London, N.1. [3800]

**25**—WATT A.C. Mains Amplifier, complete with M.C. and P.U.—£12—93, St. Julian's Farm Rd., S.E.27. [4045]

**TRADERS**, send for catalogue, 6d. stamps; mains receivers, all the best makes.—Perseus Radio, Burton-on-Trent. [4047]

**B.T.H.** Amplifiers.—Small type A.C./H.L. A.C./P., and 2-A.C./P.'s in push-pull volume control, etc.; £3 each, complete with valves.

**12**—WATT Type, with 2-P.P.5/400's push-pull in output stage; £15; brand new.

**B.T.H.** Pick-up Tone Arms, 3/-; carriage paid, cash with order or c.o.d.—Ward, 12, Tredgar Rd., Bow, E.3. Advance 3668. [4090]

**PRIVATE**—Practically new 8-valve Super Het. Gambrell radio-gram, A.C. 200-260 volts; cost 51 guineas, accept 18.—Summers, 25, Victoria St., S.W.1. [4084]

**10**—VALVE Superhet, 110-240 A.C., 15-2,000 metres, silent A.V.C. static suppressor, tone control, pick-up jack, 7 watt output, and special Magnavox speaker.—55, Grove Av., N.10. Tudor 5706. [4083]

**ARMSTRONG** 1934 Universal A.C.-D.C. 4v. Chassis, incorporating 3 tuned circuits, 9 kilocycle separation, giving practically superheterodyne performance, full vision scale, one knob tuning, combined one knob switching, 1½ watts output, 75/-; with valves, 114/-.

**ARMSTRONG** Latest 4v. A.C. Chassis, 3 tuned circuits, 9 kilocycles separation, square peak, single knob tuning, high frequency pentode, power grid detection, multi-grid 2½ watts output, ideal for making radio-gram, 79/-; with valves, 118/-; both models fully guaranteed, 7 days' trial, demonstration any time.—Phone: Gulliver 3105. Armstrong Co., 100, King's Rd., N.W.1. [3883]

**1934** Superhet Chassis A.C. or D.C. 6-valve, highly selective, 60 to 100 stations guaranteed; 7 tuned circuits, moving coil speaker; one dial tuning, provision for pick-up, 2½ watts output; built to last, fully guaranteed; 155/-; valves extra, 77/6.—Phasodyne Radio Co., 64, Queensborough Terrace, W.2. [4050]

**AMPLIFIERS**, by Radiolab, 3-stage and rectifier, 8 watts dissipation, 100-240 volts A.C. input, all resistance coupled, provision for loud speaker, field 200 volts D.C., 4 volts A.C. for heaters of radio chassis, totally enclosed in black crystalline finished steel case; price with valves £5 10, less valves £3 15—L. Eastwood, 70, Pitfield St., Old St., N.1. Clerkenwell 7693. [0411]

## ACCUMULATORS—BATTERIES.

**FUEL** Your Wireless with Fullers H.T. Accumulators. 120 volts 6,500 milliamps, delivered free on first payment of 7/6; lists free.—Leslies Radio, Catford, London. [4078]

# PILOT AUTHOR KITS

Exact to Specification

## A.V.C. STRAIGHT 4 RECEIVER UNIT

These are the parts the Author used.

	£	s.	d.
1 POLAR "Star Minor" 4-gang condenser	1	5	0
1 POLAR "Full-Vision" Semi-circular Drive Dial for above	1	5	9
1 COLVERN set of 4 Ferroport coils on chassis, consisting of F.10, F.11, F.12, and F.13	2	10	0
3 BULGIN H.P.9 Screened H.F. chokes	10	6	
2 DUBILIER Electrolytic condensers, 8 mfd., 450 volts peak working	11	0	
1 DUBILIER L.C.G. Terminal Type, 2 mfd., 550 volts, D.C. working in rectangular metal container	10	0	
1 DUBILIER 9200 Fixed condenser, non-inductive, 2 mfd., 250 volts, D.C. working	3	6	
2 DUBILIER 9200 Fixed condensers, non-inductive, 1 mfd., 250 volts, D.C. working	5	0	
7 DUBILIER 9200 Fixed condensers, non-inductive, 0.1 mfd., 250 volts, D.C. working	14	0	
5 DUBILIER 9001 mfd. Fixed condensers, Type 665	2	6	
2 DUBILIER .0005 mfd. Fixed condensers, Type 665	1	6	
1 DUBILIER .0005 mfd. Fixed condensers, Type 670	1	6	
1 CLAUDE LYONS Humdinger Resistor, 30 ohms	1	6	
1 BULGIN P.R.10 Wire-wound resistance, 7,500 ohms, 20 watts	2	6	
1 ERIE Resistance, 100 ohms, 1 watt	1	0	
3 ERIE Resistances, (1) 500 and (2) 500 ohms	3	0	
1 ERIE Resistance, 500 ohms, 3 watts	1	0	
10 ERIE Resistances, (2) 1,000 ohms, (1) 2,000 ohms, (1) 5,000 ohms, (1) 15,000 ohms, (3) 20,000 ohms, (1) 60,000 ohms, (1) 500,000 ohms, 1 watt	10	0	
1 ERIE Resistance, 1 megohm	1	0	
3 ERIE Resistances, 2 megohms	3	0	
1 MAGNUM (Special) Tuned volume control, 250,000 ohms	5	0	
1 FERRANTI A.F.3 L.F. Transformer, 1:33	1	10	0
1 R.I. D.Y.51 L.F. choke, 20 henrys, 60 mA.	13	6	
4 CLIX Chassis Mounting Standard Model Valve holders, 5-pin	3	0	
1 CLIX Chassis Mounting Floating Model Valve holder, 7-pin	1	0	
1 BULGIN 8.98 Double-pole change-over switch	1	3	
1 BULGIN 8.102 on-off toggle switch	1	3	
1 BULGIN 8.80 on-off toggle switch	1	6	
2 BULGIN K.14 Knobs	0	9	
1 WILBURN 3-way connector	2	6	
1 BULGIN 3-way battery cable, with twin 70/36 leads	2	3	
2 BULGIN P.3.5-pin plugs	6	0	
4 BELLING-LEE "B" Ebonyite shrouded terminals, A. E. pick-up (2)	2	0	
2 Lengths of screened sleeving, 6 lengths Bystoflex, 2 oz. No. 30 Annealed copper wire	3	0	
1 HAYNES Radio Metal chassis complete with screws, nuts and washers	15	0	
<b>KIT A. Cash or C.O.D. Carriage Paid</b>	<b>£12 15 6</b>		

### POWER UNIT

1 BRYVE AB573C Mains transformer	£	s.	d.
1 SAVAGE "Massflow" R.27M L.F. smoothing choke	2	10	0
2 DUBILIER L.C.G. Terminal Type fixed condensers, 4 mfd., 550 volts, D.C. working in rectangular metal containers	1	18	8
2 CLIX chassis Mounting Standard Model Valve holders, 5-pin	1	6	
1 WILBURN 3-way connector	2	6	
2 Lengths Bystoflex, 1 oz. No. 20 Annealed copper wire, etc.	1	10	
1 HAYNES Radio Metal chassis, complete with nuts, screws and washers	10	0	
<b>Cash or C.O.D. Carriage Paid</b>	<b>£8 12 6</b>		
1 Valve Marconi or Osram, M.U. 14	£1	0	0

**RECEIVER KIT** Author's Kit of **FIRST SPECIFIED PARTS** for Receiver Unit as above, including Metal Chassis, less valves, cabinet and speaker. **Cash or C.O.D. £12-15-6 Carriage Paid** Or 12 monthly payments of £1-3-6.

**POWER UNIT KIT** Author's Kit of **FIRST SPECIFIED PARTS**, as above, excluding valve. Specified Valve: £1-0-0. **Cash or C.O.D. £6-12-6 Carriage Paid.** Or 12 monthly payments of 12/3.

**COMPLETE KIT** Comprising Receiver & Power Units of **FIRST SPECIFIED PARTS** complete with all specified valves, and Baker's S.P.D. Black Cone Speaker, but less cabinet. **Cash or C.O.D. £30-8-0 Carriage Paid.** Or Deposit **£6.8.0** & balance 11 monthly payments of **£2-8-0**

**FINISHED INSTRUMENT** Ready Assembled, Receiver & Power Units, Exact to Specification, with valves, but less cabinet. Aerial tested. H.P. Terms on application. **Cash or C.O.D. £35-0-0 Carriage Paid.**

**IMMEDIATE DELIVERY CASH—C.O.D.—H.P.**

**FOREIGN ORDERS.** Send one-third value of goods with order. Balance (including forwarding charges) payable to our forwarding agents on delivery. Insurance effected if desired. All orders carefully executed and expertly packed by special export staff.

**PETO-SCOTT CO. LTD.** 77, CITY ROAD, LONDON, E.C.1.

West End Showrooms: 62, High Holborn, London, W.C.1.

## NUMBERED ADDRESSES.

For the convenience of private advertisers, letters may be addressed to numbers at "The Wireless World" Office. When this is desired, the sum of 6d. to defray the cost of registration and to cover postage on replies must be added to the advertisement charge, which must include the words Box 000, c/o "The Wireless World." All replies should be addressed to the Box number shown in the advertisement, c/o "The Wireless World," Dorset House, Stamford Street, London, S.E.1. Readers who reply to Box No. advertisements are warned against sending remittance through the post except in registered envelopes: in all such cases the use of the Deposit System is recommended, and the envelope should be clearly marked "Deposit Department."

## DEPOSIT SYSTEM.

Readers who hesitate to send money to advertisers in these columns may deal in perfect safety by availing themselves of our Deposit System. If the money be deposited with "The Wireless World," both parties are advised of its receipt.

The time allowed for decision is three days, counting from receipt of goods, after which period, if buyer decides not to retain goods, they must be returned to sender. If a sale is effected, buyer instructs us to remit amount to seller, but if not, seller instructs us to return amount to depositor. Carriage is paid by the buyer, but in the event of no sale, and subject to there being no different arrangement between buyer and seller, each pays carriage one way. The seller takes the risk of loss or damage in transit, for which we take no responsibility. For all transactions up to £10, a deposit fee of 1/- is charged; on transactions over £10 and under £50, the fee is 2/6; over £50, 5/-. All deposit matters are dealt with at Dorset House, Stamford Street, London, S.E.1. and cheques and money orders should be made payable to Illiffe & Sons Limited.

**SPECIAL NOTE.**—Readers who reply to advertisements and receive no answer to their enquiries are requested to regard the silence as an indication that the goods advertised have already been disposed of. Advertisers often receive so many enquiries that it is quite impossible to reply to each one by post. When sending remittances direct to an advertiser, stamp for return should also be included for use in the event of the application proving unsuccessful.

## MAINS EQUIPMENT

**VORTEXION** Lead Again.

**VORTEXION** A.C./34, used by author in construction of A.V.C. Three, as illustrated, 18/-.

**VORTEXION**—Please note brown lead omitted in blue print, is screened primary connection and should be earthed to chassis.

**VORTEXION**, Wimbledon, for 99.9% reliable transformers.

**IF** You Haven't Tried Them Yet Ask Someone Who Has, or call and inspect complimentary letters.

**GUARANTEED** 12 Months, and within 5% normal and 2½% super models, neat shrouding, with detachable feet, as used by Government Departments, etc., etc.

**VORTEXION**—New Monodial transformer, 200-250, 50 cycles, 425-0-425, 120 m.a., 4v. C.T. 3a., 4v. C.T. 1a., 4v. C.T. 1a., 4v. C.T. 6a., screen primary, open type, 20/-; shrouded, 22/-; super shrouded, 25/-; weight 14lb., carriage 2/- extra; 10 henry choke, 5/6, post 9d.; 20 henry, 8/6.

**VORTEXION**, for A.V.C. Straight Four, 200-250 input, 450-0-450v. 120 m.a., 4v. 2.5a. C.T., 4v. 5-6a. C.T., with screened primary, shrouded in cast aluminium to prevent hum, 23/-; with terminals on mains as in A.V.C. III, 25/-.

**VORTEXION** 26h. 120 m.a. choke, 140 ohms, in die cast shrouding to match, 12/6.

**VORTEXION**—5-watt Monodial A.V.C. model, 400-0-400, 120 m.a., 4v. 6a., 4v. 3½a., 4v. 2a., 4v. 1a., super screened, 20/-; shrouded, 24/-.

**ALL** Secondaries Centre Tapped.

**VORTEXION**—250-0-250 60 m.a., 4v. 1 to 2a., 4v. 2 to 4a., open type, 10/6; shrouded, 12/6; post 9d.

**VORTEXION** D.C.4 Choke, specified for D.C. superhet; 8/6.

**VORTEXION** Transformers, tested with 2,000 volts between windings.

**VORTEXION**—Ferrocart III, 350-0-350, 60 m.a., 4v. 2.5, C.T., 4v. 3.5, C.T.; open type 13/6, shrouded 16/-; post 9d.

**VORTEXION**—Super model for H.T.8 or 9 or 10, 4v. 1 to 2, 4v. 2 to 4; open type 14/6, shrouded 16/6; post 1/-.

**VORTEXION**—350-0-350, 120 m.a., 4v. 2 to 5a., 4v. 2 to 4a., 4v. 2.5a.; open type 14/6, shrouded 16/6.

**VORTEXION**—400 or 450 or 500v., 120 m.a., 4v. 2 to 5, 4v. 2 to 5, 4v. 2.5a., open type 19/-, shrouded 23/-.

**VORTEXION**—400 or 450 or 500, 150 m.a., 4v. 4a., 4v. 2.5, 4v. 2, 4v. 2, 4v. 2, core size 2½x1¼in., a superb job, 2% regulation, 35/-; shrouded with terminals, less terminals, 30/-, open type 26/-; post 1/3.

**VORTEXION** Auto Transformers to B.E.S.A. Specification, 100, 110, or 120v. to 200, 220 or 240 volts, 60 watts, 9/-, post 9d.; 120 watts, shrouded 12/6, open type 10/6, post 1/-; 200 watts, open 14/6, shrouded 16/6, post 1/-; 2,000 watts, £4/10.

**VORTEXION** 600-watt Transformers; £4/10, carriage free.

**VORTEXION** 30h. at 60 m.a. Chokes, 5/6; 40h. at 60 m.a., 8/6; 30h. at 150 m.a., 200 ohms, 10/6 open type 12/6 shrouded.

**VORTEXION** Transformers Made to Your Specification; price according to wattage, 6v. filaments same price unless wattage grossly exceeded; special quotations by return.

**VORTEXION** (S. A. BROWN), 182, The Broadway, Wimbledon, S.W.19. Tel.: Liberty 2814. [4066]

**TRADERS**—Get all requirements (catalogue 6d.).—Perseus Radio, Burton-on-Trent. [4048]

**TANTALUM** for A.C. Chargers, H.T. and L.T.—Blackwell's Metallurgical Works, Ltd., Garston, Liverpool. [3448]

**Mains Equipment.—Contd.**

**SERADEX** Products again Specified by "The Wireless World."

**K**IT of Resistors for A.V.C. Straight Four, 11/4. (Sera-dex resistors save you 8/8 on this kit.)

**SERADEX** Mains Equipment List Now Ready, giving details of many types of mains transformers and clocks, also L.F. transformers, etc.

**SERADEX** Resistance for Television, etc.: illustrated catalogues available shortly.

**SERADEX** Battery Chargers, valve and Westinghouse rectified; several new models now available; send for illustrated catalogue. Trevor Pepper, 575, Moseley Rd., Birmingham. [4070]

**N.P.** Have the Following: A.C. Battery Chargers at bargain prices.

**N.P.**—Special Westinghouse, rectified, 24 volts 2 amps, ammeter, variable resistance; new £8, bargain 85/-.

**N.P.**—As above, 25v. 3 amps.; this is new and unused; cost £12, exceptional offer, £8/15.

**N.P.** Have a Tungar, 75v. 6 amps.; cost £22/10, good as new, £12/10.

**N.P.**—As above, 7.5 to 15v. 5 to 3 amps.; cost £6/10, bargain 70/-.

**N.P.** Send Trade List and Photographs of Chargers, from 65/- to £17; please state the model in which you are interested.—Nash Products, Ltd., Dept. W.W., Stechford, Birmingham. [4007]

**A**PHE Transformers, shrouded, insulated terminals, tapped primaries, centre tapped heater secondaries, 2 years' guarantee.

**A**PHE 0-135v. 90 m.a., 4v. 2-4a., for H.T.7, 10/6; 0-200v. 180 m.a., 4v. 3-4a., for H.T.8, 13/6; 0-240v. 200 m.a., 4v. 1-2a., 4v. 3-4a., for H.T.9, 14/6; 250-0-250v. 60 m.a., 4v. 1a., 4v. 3-4a., 13/6; 350-0-350v. 120 m.a., 4v. 1-2a., 4v. 3-4a., 4v. 2-3a., 17/6; postage 1/-.—H. H. Bradley, 148, Norwich Rd., Ipswich. [3979]

**"DULCI"** Unused D.C. Eliminators. 25 milliamps output; 13/- each; post paid, cash with order or c.o.d.—Ward, 12, Tredegar Rd., Bow, E.3. [4093]

**B**ATTERY Charging Equipment and H.T. Eliminators. We have for disposal, Standard 1933 models of our battery chargers, new, guaranteed and reliable, outputs of 20 volts (model "J"), 24 volts (Q), 72 volts (S), at 6 amps. for 50% off list price; also Standard 20 m.a. eliminators, Westinghouse rectifier, at 26/6.—Write for illustrated folders to Rectifiers, Ltd., Brierley St., Leicester. [3985]

**CABINETS.**

**R**AUDIO-GRAM Cabinets; fully illustrated list free; remarkable values.—Gilbert, Cabinet Maker, Swindon. [1686]

**E**PTON Leads Again!—Philco polished walnut cabinets, undrilled, 15x12 1/2 x 7 1/2, 10/6; Philomel cabinets, 15 1/2 x 15 1/2 x 9 1/2, 8/9; Botoiph portable cases, 12x10x7, 8/6; portable gramophone cases, 15x10 1/2 x 6 1/2, 6/9.—Epton, 23, New Rd., Chingford, E.4. [4086]

**M**ANUFACTURER'S Clearance Lines of Cabinets for Radiograms, loud-speakers, and radio sets; hundreds to select from; send us particulars of your requirements, giving size of set, etc.—H. L. Smith and Co., Ltd., 289, Edgware Rd., London, W.2. [3852]

**DYNAMOS, ETC.**

**£5**—720v. 500 m.a. B.T.H. generator, suit transmitter or amplifier.—Griffiths, "Silverlee," Porthcawl. [4059]

**R**OTARY Converter, 220/8v. D.C., 3 amp., 75/-; motor, 1-40h.p., 230v. D.C., 35/-.—Apply Doone, Lode Lane, Solihull. [4088]

**R**OTARY Converters, 220 volts D.C. to 200 volts A.C., capacities up to 0.44 K.V.A.; from £4/10.—Milo Engineering Works, Milo Rd., East Dulwich, S.E.22. Phone: Sydenham 4422. [4046]

**LOUD-SPEAKERS.**

**H.D.** Radio Electrical Service Offers Surplus of a Set Manufacturer, every article guaranteed new.

**M**OVING Coil Speakers, Magnavox type D.C.144, 2,500 ohms or 7,500 ohms complete with transformer at 19/-; type D.C.142, same voltages, at 26/-; all fitted Humbuckers; all goods carriage paid; cash with order or c.o.d.—No. 9, Kingly St., London, W.1. Regent 6240. [3880]

**E**POCH A.C. Domino and O.T.D.B. cost £12/10, as new; £6/10.—Harman, 2, Noel St., Islington, N.1. [4042]

**T**RADERS.—Loud speakers of all kinds, with your other requirements; catalogue 6d.—Perseus Radio, Burton-on-Trent. [4049]

**30/-**—B.T.H. R.K. moving coil speakers, 6in. cone, new and unused, guaranteed; these speakers are the type as used in cinema sound equipment, suitable for public address work; weight 30lb., and vastly superior to the cheap speakers now on the market, 100 volts, 150 volts, and 200 volts D.C.

**27/6**—6-volt D.C. speakers, as above; £2/7/6 speakers as above for 100-250 volts A.C., complete with field rectifier.

**B.T.H.** Transformer, brand new, ratios 1-1, 2-1, 20-1, and 30-1 microphone; 7/- each.

**C**ARRIAGE Paid, cash with order, or c.o.d.—Ward, 12, Tredegar Rd., Bow, E.3. Tel.: Advance 3668. [4092]

**A**MERICAN Rola M.C. Speakers, K. type, 2,000, 2,500, and 6,500 ohms standard model 7 1/2 in. cones 18/-; Senior 9in. cones, at 25/-; P.M.'s Standard and Seniors also in stock, cobalt magnets; state power or pentode when ordering; dual-balanced pairs matched to customers' requirements; P.M. Midgets, in patent baffle cabinet, black leatherette finish, at 32/-, wonderful tone, reproduction crisp, no high tone loss, and a drum sounds like a drum, not a tin kettle; also supplied for class B, 2/- extra, makes a battery job sound like a mains set; all goods carriage paid, cash with order or c.o.d. Not sure which speaker will do your job best, send stamped addressed envelope and get real honest advice.—K.C. Radio Electric, 14, Hangle St., London, W.C. [4067]

A Word in Your Ear on Moving Coil Speakers



FACT No. 4.

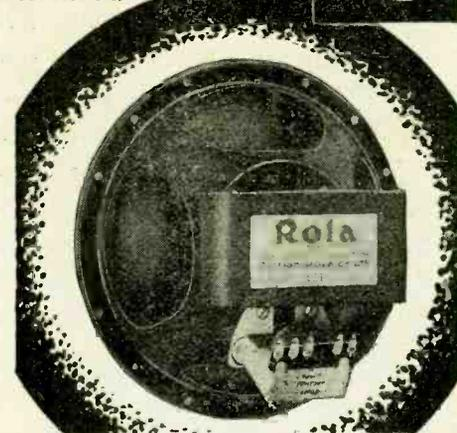

**ROLA**  
the World's Finest Reproducers

**SOME Speakers Look like ROLA but NONE Can Rival its PERFORMANCE**

It is easy enough to copy the appearance of a Rola speaker, but Rola performance is something that you simply cannot get except from a genuine Rola unit. Rola speakers are backed by over ten years of scientific research and practical experience. They are made in Europe's most modern and best equipped speaker factory. No wonder their realism and reliability is never even approached. If you want the finest results from your set follow the example of nearly all British Radio Manufacturers and install Rola.

The model illustrated is the Rola F-7PM (9" dial), Price 60/-.

The man who demands Radio at its best and who can appreciate the well-nigh perfect interpretation of every note will find that this Speaker offers him a degree of realism hitherto unknown in Radio Reproduction. For brilliance of tone this outstanding model is definitely in a class by itself.

**Over 4 Millions in Use EXTENSION SPEAKERS**

There is a correct Rola Extension Speaker for practically all British Radio receivers. Rola speakers are used by nearly all British Radio Manufacturers. As it is highly desirable to have the speech coil impedance of the Extension Speaker similar to that of the speaker in the receiver the necessity for using Rola Extension Speakers is manifest.

Write to-day for List.

**THE BRITISH ROLA CO. LTD.,**  
MINERVA ROAD, PARK ROYAL, N.W.10  
Phone: Willesden 4322-3-4-5.

**ROLA**  
SPEAKERS  
for better  
Radio Reception

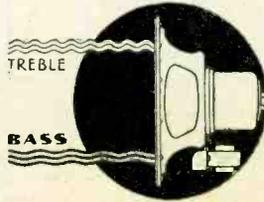

**Loud-Speakers.—Contd.**

**R**AUDIO AGENCIES Have for Disposal New Moving Coil Speakers, all guaranteed, sealed cartons, approval willingly, all worth three times the advertised prices, real hefty jobs: Magnavox X Core (U.S.A.) Juniors, 7 1/2 in. cones, 2,500 or 6,500 ohms, at 18/-; Seniors, same voltages, 8 1/2 in. cones, 25/-; state if power or pentode transformer; Rola (U.S.A.) K type Juniors, 7 1/2 in. cones, 2,000, 2,500, or 6,500 ohms, at 18/-; Seniors, 9in. cones, same voltages, 25/-; state which transformer; also a number of Junior and Senior permanent magnets, class B and duals; all goods carriage paid; cash with order or c.o.d.—Radio Agencies, No. 37, Albemarle St., London, W.1. [4020]

**VALVES.**

**8/9**—Ostar Ganz valves, any type; buy a spare set while our stocks last, state type and voltage required; c.o.d., postage paid.—Kay, 167, City Rd., London, E.C.1. [3814]

**E**PTON Leads Again!—This week's bargains: Lissen S.G.215, P.T.2, 6/6; H.L.2, 3/6; also following A.C. General Purpose, Tungram A.R.4100, Priotron W.415N, Vatea R.V.4100, 4/5; and other non-ring valves.—Epton, 93, New Rd., Chingford, E.4. [4087]

**A**LL Types of Brand New American Valves in Stock, first class makes, guaranteed; 247, 235, 224, 244, 242, 238, 46, 59, 89, 2A.7, 12/-; 80, 45, 226, 227, 8/-; 250, 281, 210, 17/6; post paid, cash with order or c.o.d.—Ward, 12, Tredegar Rd., Bow, E.3. Phone: Advance 3668. [4091]

**NEWMAN**, the Valve Man!—Just arrived, 2,000 brand new latest type American valves, all boxed, guaranteed R.C.A. manufacture; 235 11/-, 224 12/-, 236 13/-, 247 13/6, 237, 13/-, 233 15/3, 245 8/-, 244, 14/-, 227 8/-, 226 6/-, 280 8/-, 242 14/-, 232 13/6, 6A7 16/-, etc.; send us your enquiries, prompt attention for cash or c.o.d.—Newmans, 309, Roman Rd., Bow, E.3. [3882]

**S**PECIAL Offer.—Valves by world-famous Continental manufacturers, fully guaranteed, screen grid, variable mu screen grid, high magnification screen grid, low magnification screen grid, H. HL, L, RC; all the above standard mains type, 4/6 each; Philips 328 valves, 5/6; 329 lamps, 2/-; the following 4-volt battery valves at 2/- each: H. HL, L, power.—Premier Supply Stores, 20-22, High St., Clapham, S.W.4. Macaulay 2188. [3911]

**COMPONENTS, ETC., FOR SALE.**

**R.** SELECTED Parts for Sale, as new, c.o.d. or "Wireless World" deposit system, which we recommend if in doubt as to the splendid value offered; we take risk of damage in transit to our customers; goods tested for callers and guaranteed.

**F**ERRANTI MI, Speaker P.M., without transformer, £3/12/6; pair Earl dual speakers, 200v. D.C., on baffle, 35/-; Macom pick-up and universal motor, complete unit, 30/-; Epoch 20c speaker, new, 27/6; R.I. Q.P.P. input transformer and choke, second-hand, 19/-; Radiophone Radiopack, new, straight type with volume, 45/-; Varley impedance, matching transformer, for high resistance speakers, 7/6.

**R**ADIOPHONE Disc Drives, new, with large silver D.X.V. escutcheon plate complete, fit 3/4 in. spindle, read 0-100 from left to right; 5/6, post free.

**J**.B. 3-gang, with drive R3, 10/6; H.M.V. No. 7 pick-up with transformer, 10/6; Limit senior P.U., 15/-; Limit reliance, 7/6; Heayberd 50II 150 m.a. choke, 9/6; Heayberd 4v. 3 amp. L.T. transformers, 200/250v., 6/-; Varley Nicore 2 chokes, 5/6; Telsen 15H 40 m.a. chokes, 4/-.

**M**ETERS.—Ferranti 0-10 amp., flush, 15/6; 0-15 m.a. flush, as new, 22/6; Weston type, 506 flush, 0-10 m.a., 20/-; Weston 0-500 m.a. flush type, 501, 21/6; Silam 0-50 m.a. flush, 15/6; Heayberd baseboard, 0-200 m.a., 12/6; Everett projecting 0-240v. A.C., with resistance box, meter takes 15 m.a., 20/-.

**R**ADIOPHONE Pots, with switch, 8,000, 10,000, 11,500 ohms, 2/6; without switch, 5,000, 100,000 ohms, 2/-.

**S**PECIAL Offer of 3v. and Rectifier (valve) Chassis, from Yagerphone, all guaranteed, new, and very well made, chassis only 50/-, with valves 90/-, carriage forward.

**R**YALL'S RADIO Offer Reliable Resistances, suitable for all sets where a 1-watt resistance is specified, in values 100, 250, 500, 1,000, 2,000, 5,000, 10,000, 15,000, 20,000, 25,000, 30,000, 40,000, 50,000, 75,000, 100,000, 150,000, 250,000, 1/2-meg., 2-meg., all values stated in ohms, 6d. each; also 2-3-watt type, 1,000, 10,000, 9d.; also in 1 1/2-watt type; values available for "W.W." sets, 7d. each.

**N**EW Output Transformers Similar to R. and A., ratio 18/23/32, 5/-; Telsen 0.05 mica condensers, 2/3; T.C.C. 0.01 mica type M., 1/-; new Paxolin formers, 1in., slotted with guiders, 8d.; T.C.C. 2 mf., 350v. working, 1/6; T.C.C. 4x4 mf., 4/-; H.M.V. ditto, 4/6; T.C.C. 4x4x1 1/2 mf., 4/8; H.M.V. ditto, 4/-; Ryall's 0.1 Tubular non inductive wire ends.

**E**DISON BELL 10,000 Eureka, wire wound, with holders, 1/-; Edison Bell 0.0005 universal log all metal condensers, 1/6, new.

**S**PECIAL Offer of Pye 20h. Chokes, 40 m.a., 130 m.a., maximum D.C. resistance 300 ohms, in brown crystalline finish, new, unused, Pye 32h. chokes, D.C. resistance 750 ohms, 30 m.a., 80 m.a. maximum, ditto, 6/3 each, post free.

**R**YALL'S RADIO, 33, Chancery Lane, London, W.C.2 (nearest Tube Chancery Lane; bus 67 passes door, or tram to Savoy St.). Holborn 3529. Open Saturday afternoon. Close 7 p.m., Thursdays 1 o'clock, Saturday 6 p.m.

**R.** [4047]

**P**REMIER.

**P**REMIER SUPPLY STORES Offer the following Set Manufacturers' Surplus New Goods at a fraction of the Original Cost, all goods guaranteed perfect, carriage paid over 5/-, under 5/- postage 6d. extra (Ireland, carriage forward).

**E**LIMINATOR Kits, including transformer, choke, Westinghouse metal rectifier, T.C.C. condensers, resistances and diagram, 120v. 20 m.a., 20/-; trickle charger 8/- extra; 150v. 30 milliamps, with 4v. 2-4 amps. C.T., L.T., 25/-; trickle charger, 6/6 extra; 250v. 60 milliamps, with 4v. 3-5 amps. C.T., L.T., 30/-; 200v. 100 milliamps, with 4v. 3-5 amps. C.T., L.T., 49/6; 300v. 60 milliamps, with 4v. 3-5 amps. C.T., L.T., 37/6.

(This advertisement continued on next page.)

# Even a child can appreciate Hartley-Turner Reproduction

The following extract from a Headmaster customer's letter is interesting:

"I want to say how much we like the speaker. It is much preferable, infinitely so, to the one we were using. I took a test with a class of 24 children on speech, first yours and then the —, then yours again, followed by the —, and told them to listen carefully to both. Twenty-two out of the 24 were positive in their opinion that they could hear more easily when yours was in circuit. A good result but, of course, a foregone conclusion."

The other loudspeaker sells at about the same price as our own

D.C. Model - - 7 Gns.  
A.C. Model - - 8 Gns.

In collaboration with Purley Radio, Ltd., 18, Tudor Court, Purley, we are giving a demonstration of Hartley-Turner Reproduction at the Queen's Hall, South Croydon, on November 29th, from 8.30 p.m. to 12 midnight. Come and hear something you have never heard before!!

## HARTLEY-TURNER RADIO LTD.

Thornbury Road, Isleworth, Middlesex  
Phone: Hounslow 1854.

## GENUINE REISZ MICROPHONES

can be obtained from us. The real marble-block B.B.C. Marconi-Reisz.

A No. 11 Home Recorder Mike at 5/6 will give you good results and a large amount of pleasure when used with your radio set. A Reisz microphone needs ample and good quality amplification beyond the power of most users, but our microphones are designed for the every-day user. We are makers and carry the biggest and most varied stock in London; 25 Types to choose from.

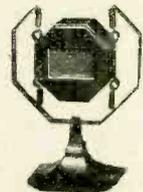

EILSEL P.A. Mike (as advertised) 70/- with stand

Our famous Button Insets for detectaphone experiments are only 1/- L.R. Volume controls, 6d. For making your own Mike, Carbon Granules in glass capsule, Grade 1, 8d.; No. 2, 5/6

1/-; No. 3, fine 1/6; No. 4, extra fine, 2/-; Back Blocks, 3d. Diaphragms, 4d. Button, with 2in. mica diaph., 1/6. Mounted on pedestal, 2/6. Hand Mikes in 2in. case, No. 11 at 5/6; Superior Type, No. 11B, 7/6. Fay Mikes, factory throwouts, 8/-; Lesdix No. 10B Pedestal, 10in. high, 12/6. Lesdix Superior No. 12BB Ring, 14in. Pedestal, 18/6. W.E. Type Table Model, 5in. dia., for lectures, 35/-. Genuine first class Studio Recording Mikes, as new, ex a talkie studio, Edison Bell, Goodson Grams etc., B.T.H. Moving Coil P.M. £5; Amplion, £5; Browns D. £12; Voight Electrostatic, £10; Isranic Transverse, £13 10/-; Western Electric P.A., £14; Siemens H. Ribbon, £50 Moving Coil for £20; famous Marconi-Reisz B.B.C. Model, £25.

## LESDEX SERVICE CHARGERS A.C.—D.C.

We have 25 models to offer and our prices are low for special requirements. Three popular sizes are the AC109A for 36 cells, the AC106 for 108 cells, and the Lesdix Super Six for 200 cells. Write for "CHARGER" LEAFLET "W."



ELECTRADIX RADIOS,  
218, Upper Thames Street, London, E.C.4.  
Telephone City 0191

## Components, etc., for Sale.—Contd.

(This advertisement continued from previous page.)

T.C.C. Condensers, 750v. working, 2 mf., 3/6; 4 mf. 6/-; 4 mf. 450v. working 4/-, 250v. working 1 mf. 1/3, 2 mf. 1/9, 4 mf. 2/6, 1,500v. working Standoff insulators 0.5 mf. 1/6, 2 mf. 6/-, aqueous electrolytic 440v. working, 4 mf. 3/-, 8 mf. 3/6.

ALL the Following Lines 6d. each or 5/- per dozen: 4- and 5-pin chassis mounting valve holders; shielded screen grid or pentode leads 1-watt wire end resistances, any value; 0.1 condensers; on-off switches push-pull; polar ganging devices; 0.02 condensers, 0.5 condensers, 0.01 condensers, 0.2 condensers.

POLAR 3-gang 0.0005 Condensers, split end vanes, totally screened disc drive; 6/11.

AMSCO Triple-gang 0.0005 Condensers, with trimmers, 4/11.

T.C.C. Electrolytic Condensers, 100 volts working, 15 mid.; 1/3

PREMIER Chokes, 40 m.a., 25 hys., 4/-; 65 m.a., 30 hys., 6/-; 150 m.a., 30 hys., 10/6.

PYE Chokes, 20 or 32 hys., 4/-; Premier multi-ratio output transformers, giving 15 different ratios, 7/6.

HIGH Inductance Chokes, resistance 2,500 ohms, 80 henrys. 6/-; 5/6.

WESTINGHOUSE Metal Rectifiers: 120v. at 20 m.a., 6/6; 180v. at 30 m.a., 8/6.

HARLEY Pick-up, complete with arm and volume control; 12/6.

BRITISH RADIOPHONE Wire Wound Potentiometers, with mains switch incorporated, 5,000 ohms, 10,000 ohms, 50,000 ohms, 100,000 ohms, any value; 3/6.

KOLSTER BRANDES Gramophone Motors, dual type, can be worked by clockwork or mains, induction type 100-250 volts, 27/6, complete with all fittings and turntable.

MAGNAVOX D.C.144, 2,500 ohms, 17/6; Magnavox D.C.142, 1,000 ohms, 21/-; all complete with Hum-bucking coils; please state whether power or pentode transformer required; A.C. conversion kit for either type, 10/-.

SPECIAL Offer.—Microphones by prominent manufacturer, high sensitivity, uniform response, complete with stand, transformer and battery; listed £3/15, our price 18/6.

PREMIER British Made Meters, moving iron, flush mounting, accurate; 0-15, 0-50, 0-100, 0-250 milli-amps., 0-1, 0-5 amps., all at 6/-.

ORMOND Condensers, 2-gang, semi shielded, 2/6; wire wound potentiometers, 15,000 ohms, 1/6.

SPECIAL Offer of Mains Transformers, manufactured by Philips, input 100-115v. or 200-250v., output 180-0-180 volts, 40 m.a., 4v. 1a., and 4v. 3a., 4/6; 200-0-200v., 4v. 1a., 4v. 3a., 4/6.

ALL Premier Guaranteed Mains Transformers have engraved terminal strips with terminal connections, input 20-250 volts, 40-100 cycles, all windings paper interleaved.

PREMIER H.T.8 Transformers, 250v. 60 m.a., rectified, with 4v. 3-5a. C.T., L.T., and screened primary, 15/-; with Westinghouse rectifier, 25/-.

PREMIER H.T.9 Transformer, 300v. 60 m.a., rectified, with 4v. 3-5a. C.T., L.T., and screened primary, 15/-; with Westinghouse rectifier, 26/-.

PREMIER H.T.10 Transformer, 200v. 100 m.a., rectified, with 4v. 3-5a. C.T., L.T., and screened primary, 15/-; with Westinghouse rectifier, 26/-.

DOUBLE Spring Motors, made by Garrard, play five sides of 10in. record, complete with turntable and all fittings; 17/6.

McMICHAEL 2-screen Grid Pentode Transportable 4, complete; gets many stations; £3; no valves or batteries.

SPECIAL Offer.—Accumulator chargers, input 200-250v. A.C. to charge 2- and 4-volt accumulators at 1/2 amp.; owing to the high efficiency of the silver oxide rectifier employed charger may be used during broadcast; 9/6 each.

CENTRALAB Potentiometers: 50,000, 250,000 and 500,000 ohms, 2/- each; ditto, wire wound, 200 ohms and 400 ohms, 1/-.

A FEW More Only.—Western Electric 4211E's and 4211D's, 15/-; 4212's, £3; callers only.

WESTERN ELECTRIC Mains Transformers: 500-0-500v. 150 m.a., 4v. 3-5 amps., 4v. 2.5 amps., 4v. 2-3 amps., 4v. 1 amp., C.T., 4v. 1 amp., C.T.; 19/6.

RELIABLE Canned Coils with circuit; accurately matched; dual range; 3/- per coil.

PREMIER L.T. Supply Units, consisting of Premier transformer and Westinghouse rectifier, inputs 200-250 A.C. output, 8v. 1/2 amp., 13/6; 8v. 1 amp., 17/6, 15v. 1 amp., 19/-; 6v. 2 amp., 27/6; 30v. 1a., 37/6.

PREMIER Mains Transformer, output 135v. 80 m.a. for voltage doubling, 8/6; 4v. 3-4a., c.t., L.T. 2/- extra; Westinghouse rectifier for above, giving 180v. 30 m.a., 8/6.

PREMIER Mains Transformers, output 250-0-250 volts 90 m.a., 4v. 3-5a., 4v. 2-3a. (both c.t.), with screened primary, 15/-.

PREMIER Mains Transformers, output 350-0-350 volts, 90 m.a., 4v. 3-5a., 4v. 2-3a. (both c.t.), with screened primary; 15/-.

PREMIER Mains Transformers, output 400-0-400 volts, 100 m.a., 4v. 4-5a., 4v. 2-3a., with screened primary; 15/-.

PREMIER Auto Transformers, 100-110/200-250 volts or vice versa, 60-watt, 7/9; 100-watt, 10/-.

SPECIAL Offer of Manufacturers' Type Transformers, any input, output 250-0-250 volts, 60 m.a., 4v. 1a., 4v. 3a. (both c.t.), 8/6; H.T.8 transformer, with 4v. 3-4a. (c.t.), 8/6; with rectifier, 18/6.

FILAMENT Transformers, polished and engraved terminal boards, N.P. terminals, 4v. 3-4a., 5/-; 10v. 3a., 6/6; 12v. 1a., 5/-; 4v. 4-6a., 6/6; 14v. 4a., 6/6; 22v. 1a., 6/-; 6v. 2a., 5/-; 9v. 1a., 5/-.

(This advertisement continued on next page.)

# THE LATEST and most important development in CLASS 'B' Mains Unit design.

Our new Automatic Voltage Regulator has enabled us to produce a new Class 'B' Mains Unit giving an almost unvarying voltage output up to 55 m.A., and maintaining the economies of Class 'B'. This high quality Unit is exceptionally compact and pleasing in appearance. The only Unit on the market completely suitable for Class 'B'. Write for regulation curve and further details.

MODEL B.A. 55 for A.C. 88/6d.  
THE BRITISH MAINS UNIT COMPANY  
Cromwell House, High Holborn, London, W.C.1.

## TWO ESSENTIALS

To you, the acquisition of the "New Monodial" is essential to your complete peace of mind. To us it is essential that we keep up our stocks of second-hand goods. We have the "Monodial" Kits. Have you any surplus? Let us know what you have for disposal. As we actually have a market for any second-hand radio goods we can make you a genuine offer. Further, our alternative Component Power Unit Kit (guaranteed and incorporating Ferranti A.F.S.C.) at £6 15/- also helps considerably to bring down costs without in any way affecting performance. Drop us a note to-day.

MACINDOE & CO.,  
99, WATERLOO ST., GLASGOW.

# Micromesh THE MODERN VALVE

Literature and prices on request.

Standard Telephones & Cables Ltd., St. Chad's Place, 264, Gray's Inn Rd., London, W.C.1

## The BRITISH RADIO INSTITUTION

Founded 1930—world-wide membership, steadily increasing. Objectives—Technical co-operation between members and the advancement of radio science. Association by examination or approved qualifications. Examinations in London and Edinburgh 13th Jan. 1934. Closing date for entries 16th Dec. Balance Sheet published annually. Explanatory brochure (free) from Hon. Sec. Administrative Offices—36, GORDON SQUARE, LONDON, W.C.1. The British Radio Annual 2/- net (free to members).

## FEL-ECTRIC A.C. ELIMINATORS

From 39/6 120 v. 12 m.a. PRICE QUALITY SATISFACTION  
UNEQUALLED  
"Class B" Amplifier Unit 28/-

ASK YOUR DEALER. Phone: SHEFFIELD 29795  
FEL-ECTRIC RADIO, Garden St., SHEFFIELD.

Foremost as Pioneers

# Varley

Proprietors: OLIVER PELL CONTROL LTD.

## TRANSFORMER AND CHOKE STAMPINGS, INSTRUMENT AND RESISTANCE WIRES.

Lists Free

LUMEN ELECTRIC CO.  
9, SCARISBRICK AVE., LITHERLAND, LIVERPOOL, 21

## YOUR H.F. ANODE REQUIRES THE BEST H.F. CHOKE; USE TYPE I.D.C.,

Iron-dust Cored, with the exceptionally low self-capacity of 3 m.mfd. and with an adequate impedance for all Variable MU, and 4/6 H.F. Pentode Valves -



Admirable for Diode Circuits.  
POSTLETHWAITE BROS.,  
KINVER, Nr. Stourbridge.

Components, etc., for Sale.—Contd.

(This advertisement continued from previous page.)

**PREMIER Eliminators**, input 200-250 volts, 40-100 cycles A.C., incorporating Westinghouse metal rectifiers, output 250v. 60 m.a., S.G. and 120v. taps, 42/6; with 4v. 4a. c.t. L.T., 7/6 extra.

**PREMIER Eliminators**, output 150v. at 30 m.a., S.G., and 100 taps, with 4v. 3-4a. c.t. L.T., 37/6; or with trickle charger, 42/6.

**PREMIER Eliminators**, output 120v. at 20 m.a., S.G. and 100v. taps, 27/6; with L.T. trickle charger incorporated, 35/.

**MAGNAVOX P.M. Loud-speakers**, 7in. cone, 18/6; please state whether power or pentode transformer required.

**GRAMPION P.M. Loud-speakers**, 9in. cone, handles 4 watts; 18/6.

**GRAMPION M.C. Loud-speakers**, 2,500 ohm field, 9in. cone, handles 6 watts; 21/.

**H.M.V. Condenser Blocks**, 4x4x1x1x0.5, 250v. working, 3/6; ditto, 400v. working, 5/6.

**ELLIOT First-grade Moving Coil Meters**, 0-30, 0-50, 0-100, 0-150 milliamps, projecting types, 15/- each; 0-100, 0-150 milliamps, flush types, 17/6 each.

**PREMIER D.C. Eliminators**, output 120v. at 20 m.a., S.G. and 100v. taps; 15/-.

**ACCUMULATOR Chargers**, 200-250 volts A.C., all incorporating Westinghouse metal rectifiers, 2, 4, and 6v. at 1 amp., 17/6; 12v. 1a., 27/6; 6v. 2a., 35/-; 30v. 1a., 42/6; 50v. 1a., 42/6.

**B.T.H. Induction Type (A.C. only) Electric Gramophone Motors**, 100-250v.; 30/- complete.

**AMPLION Moving Coil Speakers**, type E.M.644, dual fields 2,500 and 5,000 ohms (100 and 200v.), with output transformer, 12/6; A.C. conversion kit for this speaker, 10/- extra.

**WESTERN ELECTRIC Condensers**, 250v. working, 1 mid. 6d., 2 mid. 1/-; 500v. working, 1 mid 1/-.

**T.C.C. Condensers**, 250v. working, 4x4x1 mid., 3/6; 6x4x2x2 mid., 375v. working, 6/11; 4x4x1, 6/-.

**SPECIAL Offer of Wire Wound Resistances**—4 watts any value up to 10,000 ohms, 1/-; 8 watts, any value up to 15,000 ohms, 1/6; 15 watts, any value up to 1,000 ohms, 2/-; 25 watts, any value up to 50,000 ohms, 2/6; 50 watts, any value up to 50,000 ohms, 3/6.

**PREMIER SUPPLY STORES**, 20-22, High St., Clapham, S.W.4. Macaulay 2138. Closed 1 o'clock Wednesdays, open to 9 o'clock Saturdays. Nearest Station, Clapham North Underground.

**PREMIER.** [4089]

**WOBURN RADIO Offer Following New and Bankrupt Stock:**

**FERRANTI Multi Radio Output Transformers**, 32-1, 23-1, 18-1, 4/11; Class B driver and choke, 9/6 per pair, with suitable valve and 7-pin holder, 22/-; S.T.500 coils, per pair, 5/6; Wego 750v. test condensers, 1 mid. 1/-, 2 mid. 1/3, 4 mid. 2/4, 0.1 mid. 250 working 1/-; Siemens 0.01x0.01 mid., 0.1x0.1 mid., 3,500v. test, 1/7; Amplion 0.0005 mica tuning condensers, 9d.; Graham Farish 0.0003 and 0.0002 ditto, 9d.; Philips 1 watt wire wound resistances, 10,000, 30,000, and 2,000, 2/3 half dozen; Clix 4 and 5-pin valve holders, 1/3 half dozen; Erie 1/2-watt 100, 300, 450, 5,000, 20,000, 25,000, 50,000, 100,000, and 1 meg., 4/6 dozen; 1 watt 350, 25,000, 40,000, 6/6 dozen; binocular chokes, 1/3; H.F. chokes, 10d.; Centralab volume controls, with switch, 20,000, 2/-; all types of valves in stock; let us quote for parts; also A.V.C. 3 and Monodial kits.—Woburn Radio Co., 7, Woburn Buildings, W.C.1. Euston 1571 (near Euston Station, back of St. Pancras Church). [4061]

**MILDMAY RADIO EXCHANGE** Offers the Following, sound and perfect:—

**RADIOPHONE 3-gang Super Condensers**, fully screened, 14/-; Ormond 2-gang ditto, 8/6; single gang ditto, 4/9; Multitone Toco 6.1, 9/6; Lewcos L.F.T.6 transformers, 7/-; Varley Nicore I, 9/-; R.I. Varitone, second-hand, 6/-; Parmeko Intervalve Transformer, heavy duty type, 17/-; Parmeko L.F. Choke, 30h. 50 m.a., 15/-; Lewcos Band Pass Filters, 6/6; Lewcos Oscillator Coils to match, 5/-; Lewcos and Wearite Superhet Coils, 4/6 each.

**FERROCART F1, F2, F3 Coils**, second-hand, 25/-; Varley BP30 and BP31, 10/- pair; Tunewell S20/25 L.F. Chokes, 6/-; Radiophone 4-gang Condenser, fully screened, 15/-; Varley Push-Pull Input Transformer, 14/-; Colverdynes, 8/- each; Set Colvern, K63, KGR, KGC, 17/6; Ganged Polar Star, 3-gang, 12/6; Colvern Super Net Coils, 14/- set, 3-gang.

**FERRANTI Chokes**, B1, 10/-; B2, 12/-; B3, 7/6; B5, 15/-; Transformers, AF3, 11/-; AF4, 8/-; AF5, 16/-; AF6, 17/-; OPM1, 10/-; OPM1c, 14/-; OPM2c, 12/-; OPM3c, 12/-; OPM6, 12/-; AF11c, 17/6; OPM13c, 12/-; B.T.H. 4-1 Transformers, 4/6; Varley L.T. Smoothing Chokes, 4/6 each.

**MARCONI PHONE 1933 Type 330 A.C. Mains Radiogram**, originally listed £30/9, circuit screen grid detector with pentode output, in solid oak cabinets, £13/13 each; only a few left.

**HAMPTON 1932 Model Table Type Radiogram**, A.C. mains, in walnut cabinet, circuit screen grid detector, with pentode output, Rola speaker, Garrard A.C. motor, Mazda valves, £10; complete.

**ALL the Above Carriage.**

**PHONE:** Clissold 5001.

**OPEN Thursday, Closed Saturday All Day.**

**24, MILDMAY GROVE, London, N.1.** [4053]

**TWO Ferranti A.F.3 Transformers:** 25/- pair.—9, Hope St., Hazel Grove, Stockport. [4038]

**METERS Moving Coil**, Weston 301; 10 m.a. and upwards, 22/6; Galvos 30-0-30, 27/6.

**NEW British Made**, 1 m.a., 27/6; 250 volts (1,000 w. per volt), 32/6; Turners 20 m.a. upwards, 17/6; thermo anmmeters, 1.5a, 22/6; French 3-range, 3 m.a., 6v., 240v., 22/6, 2-range, 3 m.a., 240v., 20/-; German 2 m.a., 25/-; 2,000 volts, 32/6; assorted makers, 25 m.a. and upwards, 10/6; laboratory apparatus in stock; meter repairs a speciality.—The Victa Electrical Co., 47, High St., Battersea, S.W.11. Phone: Batt. 0780. [0355]

# EPOCH

## Moving-Coil SPEAKERS

are Britain's Best. Therefore the best in the world.

### PRESTIGE

Each model Epoch Speaker is the outcome of research and manufacturing experience much longer and more intensive than any other make in England.

### QUALITY

Epoch Moving-Coil Speakers are renowned the world over for quality of reproduction. They are used everywhere where "Quality First" matters. They have never succumbed to the "Cheapness First" slogan. Epoch has put "Quality" into Moving-Coil Speakers 7 years ago and has led by "Quality" ever since.

### PRICE

Each model of Epoch Speaker represents much greater value for money than other makes. Epoch uses permanent magnets of 9 per cent. to 35 per cent. Cobalt Steel, the most efficient, costly and most magnetically durable: most other makes employ relatively cheap chrome or tungsten steel, or low content cobalt steel. Everything else is equally of the best, including innovations not obtainable in any other speakers.

### RANGE OF MODELS

Epoch make the most extensive and comprehensive range of Moving-Coil Speakers in the world.—The range includes:

- Models from 5in. to 28in. diaphragms.
- P.M. models from 23/6 to £8 8s.
- Dual matched and individually hand-made models.
- Energised and P.M. models for the smallest sets.
- Energised and P.M. models for the largest halls and Public Address systems.
- P.M. models for Public Relays.
- Class B models specially made to give the highest efficiency with Class B.
- Models weighing 1 lb.
- Models weighing 300 lbs.
- Many models in handsome cabinets for use as additional speakers.

## MOVING COIL SPECIALISTS

Moving-Coil Speakers. Moving-Coil Microphones. Moving-Coil Headphones. Output Transformers for M.C. Speakers. Mains Units. Class B Combinations. Class B Adaptors, Transformers and Chokes. Cabinets for speakers. Horns and Flares, etc.

### ADVERTISING

Epoch does not need to advertise extensively, since each one of the many thousands of Epoch users proclaim Epoch virtues, far and wide. Nearly 2,000 unsolicited written testimonials are on view at Exmouth House.

Write for Folder of New Season's Programme, call for a demonstration, or let us have your Moving-Coil problems.

**EPOCH RADIO MANUFACTURING Co., Ltd., EXMOUTH HOUSE, EXMOUTH ST., LONDON, E.C.1.**

Components, etc., for Sale.—Contd.

**SOUTHERN RADIO'S** Wireless Bargains.—Set manufacturers' guaranteed surplus.

**MAINS Transformers**.—250-0-250 volts 60 m.a., 4v. 1a., 4v. 2-4a., 11/-; 250-0-250 volts 60 m.a., 4v. 1a., 4v. 2-3a., 4v. 1a., 12/-; 350-0-350 volts 60 m.a., 4v. 2-2½a., 4v. 2-4a., 13/6; 350-0-350 volts 120 m.a., 4v. 2-2½a., 4v. 3-5a., 4v. 1a., 16/-; 500-0-500 100 m.a., 4v. 2½a., 4v. 3-5a., 4v. 2a., 19/-; step-up or step-down transformers, 0, 100, 110, 200, 230 and 250 volts, 60 watt output, 12/6; 100 watt output, 14/9.

**SMOOTHING Chokes**.—20 henrys, 120 m.a., 320 ohms, 8/9; 50 henrys, 60 m.a., 500 ohms, 7/8; 40 henrys, 40 m.a., 700 ohms, 6/6; Ferranti chokes, 20 henry, 60 m.a., centre tapped, 6/9 (list 21/-).

**ALL-MAINS Transformers and Chokes** Guaranteed for 12 Months, specials quoted for and delivery given within 3 days of order.

**VARIABLE Condensers**.—Lotus 2-gang 0.0005, complete with dial, knob, escutcheon, 8/6; all ganged condensers are fully screened with trimmers, and boxed; Lotus Dyblock single variable condensers, 0.0005, complete with dial, escutcheon, etc., 4/9 (list 9/6); Hydra block condensers, new, 1.5 mid., 2+2+8+2+1+1, 1,000 volt test, 7/- each; 4 mid., 2/6; 2 mid., 1/9; 1 mid., 1/-; T.C.C. 4 mid. electrolytic, 440 D.C. working, 3/- each; Hellesens 8 mid. electrolytic, 3/9 each.

**SPEAKERS**.—Permanent magnet speakers, 7in. cone, 28/- (listed 49/6); D.C. mains energised, 2,500 to 6,500 ohms, complete with humbucking coils and transformers, 16/6 (list 39/6); 7 Magnavox moving coil D.C., 2,500 ohms, 18/- each (list 39/6); G.E.C. Stork speakers, complete in magnificent cabinet, 19/6 (listed £3/15); Ormond Spot, 100U, 13/6 (list 37/6).

**CONSTRUCTORS' Kits**.—Ready Radio Meteor screen grid 3-valve kit, less valves, 26/-; with 3 Mullard valves (P.M.12a, P.M.2D.X., P.M.2a), 49/- (list £5/7/6); Universal Radio 3-valve kits, ready assembled on chassis, 12/6 (listed 45/-).

**READY RADIO "303" A Kits**, complete with cabinet, M.C. speaker, less valves, £2/5; with 3 Mullard valves (P.M.1L.F., P.M.2D.X., P.M.2), £3/5 (list £6/17/6).

**READY RADIO Meteor "A" 3-valve Screen Grid Kit**, complete with cabinet, M.C. speaker, less valves, £3/7/6; with 3 Mullard valves (P.M.12a, P.M.2D.X., P.M.2A), £4/10 (list £8/7/6).

**READY RADIO "A" 3-valve Screen Grid Kit**, as specified by Scott Taggart, £2/19/6 each (list £5/17/6); Mullard Radio for Million 3-valve battery kits, complete with 3 Mullard valves, £3/3 (list £6/2/6), all kit new, in original sealed cartons.

**B.T.H. Senior Pick-ups**, 1934 model, with volume control, 28/- each (list 37/6); Marconi pick-ups, 1934 model No. 19, 25/- (list 32/6); H.M.V. volume controls, 1/6 each (list 12/6); Radiophone volume controls, with switch, 3/- each (list 10/6); Amplion loud-speaker units, 2/3 (list 12/6).

**WE Have Purchased the Complete Liquidated Stock of a Large Northern Manufacturer and Factor**, and can offer the following special bargains:—

**DUBILIER 4 mid. Condensers** (2+1+1), 1,000 volt test, 2/9 each; 4.5 mid., 1,000 volts test (2.25+2.25), 3/- each; mains switches, 3 amp. 250 volt, 8d. each, 7/6 dozen; Lumophon D.C. mains energised moving coil speakers, 6,500 ohms, with terminals, 11/6 each (listed 39/6); Pileo All-in-One radiometers, latest bakelite, case, 9/3 each (list 12/6); Ferrocart coils, F1, F2, and F3, G1, G2, and G3, 32/- per set; S.T. 4-500 coils, 5/6 per pair; Koister Branges dual motors, for 100-250 volts, A.C. or clockwork, complete with all accessories and turntable, 25/- each (list 95/-); Edison plug-in inductance coils, all values from 20 upwards, centre tapped, 9d. each, 7/6 per dozen, assorted values; every article new.

**ALL Goods Guaranteed and Sent Carriage Paid.**

**BRANCHES** at 271-275, High Rd., Willesden Green, N.W.10, and at 46, Lisle St., W.C.2; please send all post orders to 323, Euston Rd., N.W.1.

**SOUTHERN RADIO**, 323, Euston Rd., London, N.W.1 (near Warren St. Tube). Phone: Museum 6324. [4069]

**EBURY BRIDGE RADIO** Offer the Following Stupendous Bankrupt and Set Manufacturers' Surplus Bargains:—

**A.C. H.T. Eliminators**, 200-250v. output, 150v. 30 m.a., 3 pos. tappings (one continuously variable), Westinghouse rectified, finest components, 28/6; 2 pos. tappings (one continuously variable), 25/-, post 1/3.

**D.C. H.T. Eliminators**, 200-250v., output 150v. 30 m.a., 3 pos. taps (one continuously variable), 12/6; 2 pos. taps (one continuously variable), 10/-, post 9d.

**EX-MANUFACTURERS' Mains Transformers**, suitable Ferrocart H.T. tapped 200-250v., outputs 350-0-350v. 70-80 m.a., 4v. 2-3a., 4v. 3-4a. C.T., 9/6, post 9d.; a real snip.

**EX-MANUFACTURERS' Heavy Duty Smoothing Chokes**, 50h. at 50 m.a.; 5/6, post 6d.

**PYE Mains Transformers**, 200-250v., outputs 135v. 80-100 m.a., 4v. 4a. C.T.; 5/6, post 9d.

**SPECIAL Offer** Ebury Synchronous Electric Clock Movements, robust, reliable, 200-250v. 50c., 16/6, post 6d.; write full details.

**CABINET** Bargains, beautifully finished figured walnut, and batteries, brand new, unmarked; 12/6.

**SMALLER Model**, satin walnut, 16½x13x7½; 8/6 each, post 1/3; photos, stamp; bargains.

**UTILITY 3-gang Condensers**, new, split end vanes, separate trimmers, S.M. disc drive, 10/6, post 6d.

**FINAL Clearance**, Blue Spot, 100U, inductor speakers; list 39/6, 13/6; post 1/-.

**SPECIAL Lotus Bargains**, all new, boxed.—2-gang 0.0005, S.M., disc drive, dial light, escutcheon, split vanes, separate trimmers, screened, 8/6, post 9d., list 14/-; 0.0005 single, S.M. disc drive, dial light, escutcheon, 5/11, post 6d., list 9/6.

**ILLUMINATED Disc Drives**, fit any condenser, 2/11, I post 3d., list 5/-; bakelite cased L.F. transformers, wonderful reproduction, 3-1 or 5-1; 3/11, post 4d.; list 5/6.

**GOODMAN Dreadnought P.M. Moving Coil Speakers**, 7in. cone, tapped transformer, powerful magnet; 21/-, post 1/3; list 39/6.

**CONDENSER** Bargains, all 250v. working.—T.C.C. 9 mid (4+4+1), 3/6, post 6d.; Siemens 4 mid., 2/-; Hydra 2 mid., 1/4, post 4d.; Hellesens 8 mid., electrolytic, 3/9, post 3d.

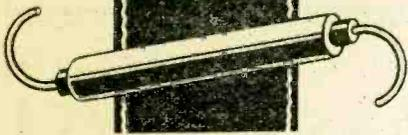

## KNOW THEM BY THEIR COLOURS

These Resistors are made from a special compound that is guaranteed for ever. Cannot disintegrate. Constant resistance. Silent in operation. In the unlikely event of any Resistor not giving full satisfaction, we will replace it willingly, or refund purchase price, without any time limit.

TRADE INQUIRIES INVITED

A set of Resistors for any advertised Constructor's Kit sent post free by return for 8d per Resistor; or sample Resistor of any value sent for 8d post free together with COLOUR CHART.



One Hundred Resistance Values from 50 ohms to 2 megohms. Each one a separate Colour Combination.

SCIENTIFIC DEVELOPMENT CO.  
55-57, Guildhall Street, PRESTON. Tel.: 4364.

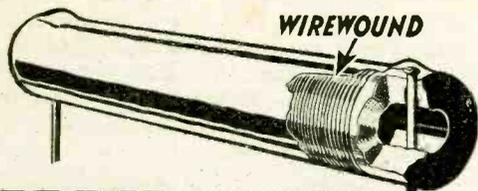

WIREWOUND

## WHY THE HYWATT?

Why have many set manufacturers chosen the Hywatt resistance for their 1934 sets? The answer's simple. The Hywatt is the most advanced resistance on the market: because—

- The element is wire. This means
  - Much Closer tolerance than in the carbon type.
  - Fixed resistance value unchangeable in operation.
- Each tdrn is insulated. This makes it suitable for high voltages, and it will not break down.
- Moisture proof and noiseless due to welding of lead wire.

Made in all values from 1-50,000 ohms.



Please write for folder, telling you all about the Hywatt, to—

Watmel Wireless Co. Ltd., Imperial Works, High Street, Edgware, London. Telephone: Edgware 0323.



C.R.C.94

### Components, etc., for Sale.—Contd.

WEST END RADIO STORES.—A few more genuine bargains: N. and K. Farrand inductor speakers; 22/6, listed 70/-.

"FAY" Home Recorders, complete with diamond stylus, tracker, sound box, etc. 5/6; blank records, 6in. 2/9 per dozen, 8in. 5/6.

"FAY" Microphones, complete stand, transformer, battery, 18/9, listed at £3/3; genuine Reisz pattern microphones, 49/6.

MAINS Transformers.—Heayberd 209 250-0-250v. 50 m.a., 4v. 2a., 9/6; Heayberd 350-0-350 60 m.a., 4v. 4a., 4v. 2a., 6/6; H.T. 8 200v. 180 m.a., 4v. 3a., 4v. 1a., 4/9; Edison Bell 400-0-400v. 120 m.a., 4v. 6v., and 7.5v., 12/6.

DUBILIER 4 mid. Conds., tapped 2+1+1 mid., 1,000v. test, 2/6; T.C.C. 8.25 mid., tapped, 500v. test, 2/6.

MAGNAVOX 2,500 ohm D.C. Speakers (pentode), 17/6; Collaro electric gramophone motors, 100-250 A.C., 35/-, listed £3.

HARLIE Pick-ups, new model, 12/6, with volume control; Dulci eliminators, D.C. 16/6, A.C. 32/6; trickle chargers, 18/6, guaranteed 1 year; Post Office galvanometers, large type, 4/6.

WE Have a Large Assortment of Modern Walnut Radio and Radiogram Cabinets; postage extra on all orders by post.

WEST END RADIO STORES, 14, Lisie St., London, W.C.2, and at 382, Coldharbour Lane, Brixton, S.W. [4052]

CONDENSER Microphones, with circuit diagram. £3/10; with amplifier, £7.—Dennis, 49, Church Lane, N.8. [4072]

FERRANTI Flush Milliammeter, 0-8, with shunt 0-16 new; cost £2, 24/-.—Temple, Knockdolian, Comrie, Perthshire. [4039]

SAMSONS SURPLUS STORES Offer the Following Genuine Manufacturers' Surplus at Wonderful Bargain Prices:—

CONDENSERS.—Siemens 2 mid., 650v. test, 1/6; 4 mid., 1,500v. test, 3/6; 4 mid., 2,000v. test, 6/-; 0.1 mid., 1,500 test, 1/6; Dubilier mica, 0.05, 2/-; Philips 1 mid., 20,000v. test, 10/-; Edison Bell 000, 4d., 3/- dozen; 00, 6d., 4/6 dozen; Elkon electrolytic, 2,000 mfd., 6/-.

MAINS Transformers.—B. & J. 350-0-350, 4v. 3 C.T., 4v. 4 C.T., 9/6; Tecalemit 350-0-350, 4v. 3 C.T., 4v. 4 C.T., 6/6; Pye, for Westinghouse H.T.7, 4v. 4 C.T., 5/6; Heayberd W.29, for H.T. 5 and 6, 4v. 4 C.T., 7/6; Marconi L.F. (new), 8-1, 7/6; Pye I.F. 707, 3.3-1, 4/6; Pye output, pentode or power, 3/11.

WEBSTER'S Automatic Record Changer, motor and pick-up, new, £6; Magnavox speakers, 2,000 ohms pentode, 17/6; 0.0005 Polar 4-gang condensers, less dial, 8/6.

CHOKES.—Pye 28 henrys 640 ohms, 3/3; 18 henrys 440 ohms, 2/11; Henry 15 ohms, 2/6; Varley 3 henrys, 3/-; Igranite 8 henrys, 3/-.

UTILITY 3-gang, with disc drive split vanes, 9/6; Umello 5-valve transportable sets, 25/-; Edisonwan talkie tone arms, 3/6; Pye 1, watt resistances, 6,000 and 10,000 ohms, Metro-Vic 15,000 ohms, 3d. each; wire-wound resistances, 25,000 ohms, 1/3; 50,000 ohms, 2/-; 120,000 ohms, 2/6.

All Goods Fully Guaranteed; postage extra on all goods.

SAMSONS SURPLUS STORES, 4, Praed St., Edgware Rd., W.2. Padd. 7851. Open Sunday mornings. [4094]

BIRMINGHAM RADIOMART Offers Several Unrepeatable Snips; limited quantities, perfect manufacturers' surplus stocks.

BARGAIN One.—A.V.C. Straight Four parts, 1 dozen Erie 1-watt, as specified, 7/3; seven T.C.C., cylindrical, 0.1 mid., 375 wkg., 3/6; six feet Lewros screened cable, 3d.; four 5-pin, one 7-pin chassis valve holder, 2/3; two T.C.C. 8 mid., electrolytics, 7/6; ditto, Hellesen, 6/3.

BARGAIN Two.—Westinghouse H.T.8, with screened primary, transformer having 4v. 3a., 4v. 1a., T.C.C., 4+6 mid., 375 wkg.; the lot, 26/-.

BARGAIN Three.—Radiophone 27/6 straight 3-gang, with trimmers and dust cover; 12/6.

BARGAIN Four.—Set three Lotus screened coils for band pass, chassis type; 5/- set.

BARGAIN Five.—Lotus heavy duty 250 m.a. smoothing chokes, resistance 150 ohms, weight 4½lb., 5/6, postage 1/-.

BARGAIN Six.—Six different Lotus wire wound resistances, 2 to 10 watt, 200 to 20,000 ohms; lot, 2/6.

BARGAIN Seven.—One each Hellesen 8 mid. 435v. electrolytic, T.C.C., 50 mid. 12v. and 6 mid. 50v.; 4/3 lot.

BARGAIN Eight.—Famous Lorenz pick-up and tone arm and 6ft. Lewros twin screened pick-up flex; 6/- the lot.

EIGHT out of Hundreds Similar Bargains at The Square Dealers, Birmingham Radiomart, John Bright St., Birmingham. [4065]

RICH Bundy E.102, 18/6; A.F.8 (unused), 6/-; T.C.C. 4 mid., 400v. working, 3/6; ditto, 800v., 8/-.—Shorter, 20, Howson Rd., S.E.4. [4040]

HEAYBERD L.T. Transformer, 4 volts, 10 amps., 7/6; choke, 30 henrys, 150 m.a., 5/-.—Tomlinson, Deansgrove, Haslingden. [4074]

PEPPER'S Final Clearance Lists Now Available; all goods guaranteed; the following are only a few examples of our value:—

FERRANTI A.F.7, 15/-; O.P.1, 7/6; O.P.M.5, 9/11; Ferranti 3-gang condenser, as new, 19/6; A.F.15c. O.P.M.16c, for Class B, 15/- each.

MILNES H.T. Unit, good condition, cost £4/14; £1/19/6 carriage fwd.

MANY Other Bargains in our List.—Pepper, 575, Moseley Rd., Birmingham. [4071]

1-WATT Carbon Resistances, 500 ohms to 1 megohm. 14d., 1/- dozen, plus postage; special for quantities. —54, Herne Hill Rd., S.E.24. [4035]

# TANNOY

'SOUND' EQUIPMENT  
FOR ALL PURPOSES—  
FROM 2 TO 150 WATTS  
UNDISTORTED A.C.  
AMPLIFIERS, SPEAKERS,  
MICROPHONES, ETC.  
FOR QUALITY AMPLIFICATION CONSULT:—

## TANNOY PRODUCTS

(GUY R. FOUNTAIN LTD.)  
CANTERBURY GROVE,  
WEST NORWOOD, LONDON, S.E.27.

\*Phone: Streatham £730 (3 lines)

Piano Tone RADIO GRAM CABINETS  
As supplied to B.B.C.

65/- POLISHED 35/-  
CABINET FOR  
No Middle Profits!

Famous maker offers finest Radio Furniture. As supplied to B.B.C. a quality and value impossible to better. Beautifully hand polished! GUARANTEED Piano-Tone acoustically.

DIRECT—on FREE TRIAL (or 10/- monthly.)  
LIST FREE! From makers.

PICKETT'S  
Piano Tone  
Cabinet (W.W.) Works, Albion Road, Bexleyheath, near London.

GOOD RECEPTION MEANS  
RECEPTION  
INSULATED AERIAL CABLE  
in the ORANGE & BLUE CARTON

"Reception" can be used either as an indoor or outdoor aerial or as an earth. It is a seven-strand insulated aerial cable drawn from pure electrolytic copper and protected with a weatherproof covering, and is definitely non-corrosive. The conductivity of the aerial is, of course, extremely high, so that when "Reception" is fitted perfect satisfaction is assured. Obtainable from all Wireless dealers, or if in difficulty apply direct to the manufacturers.

THE CONCORDIA ELECTRIC WIRE CO. LTD.  
New Sawley Nr. Nottingham.

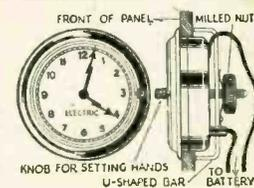

FIT THIS ELECTRIC CLOCK TO YOUR SET!  
NO MAINS NEEDED!  
KEEPS CORRECT TIME!  
NO WINDING!

Works on small battery lasting 12 months, or can be plugged into G.B. Battery without affecting reception. Uses practically no current. Fits into hole 3½" dia. in any panel up to ½" thick. Easy to fix—no screws required. Only 1" from front of panel to back of case. Swiss movement. Hands set from front. Nickel plated bezel. Useful addition to any set.

RIVERSIDE MFG. CO. LTD.,  
Dept. 20, Crisp Rd., Hammersmith W.8.  
Telephone: Riverside 0392.

COMPLETE WITH BATTERY  
POSTAGE 6D

# BENJAMIN VALVEHOLDERS

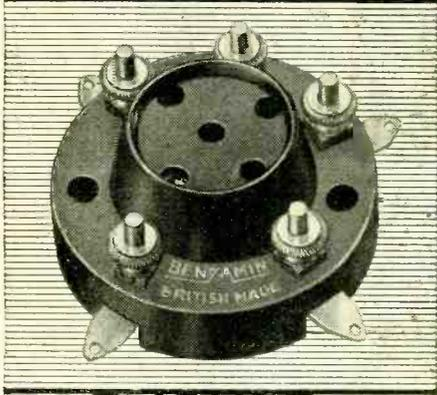

**ENSURE**

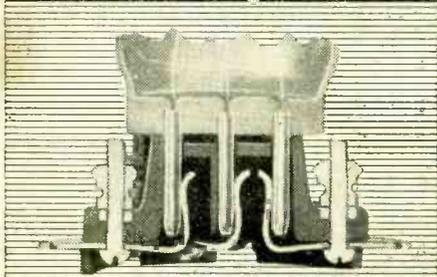

**PERFECT CONTACT**

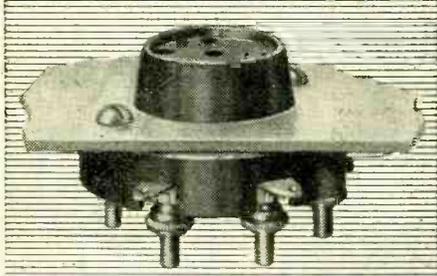

**& FLUSH MOUNTING**

The Benjamin 5-pin is a perfect masterpiece, bearing witness to the meticulous care and attention given to every little detail in its construction.

Examine the contacts; these are sprung in such a way as to ensure a maximum downward thrust on the valve pins, the main pressure being above the thick portion of the split valve leg, with the result that the valve snaps home in the holder—thus perfect contact is always maintained. The contacts, which are of course self cleaning, are taken through the body of the holder and form the solder tags. This one-piece solder tag and socket is just another Benjamin advantage.

In the lower illustration the terminals have been reversed and the valveholder is seen mounted flush beneath the baseboard. To allow for this flush mounting every terminal hole is counter-sunk to take the screw head on the terminal. You pay no more for Benjamin superiority. The price of the 5-pin is 10d.

# BENJAMIN

The Benjamin Electric Ltd., Tariff Road, Tottenham

**Components, etc., for Sale.—Contd.**

**CHAL ELECTRIC** Offers New Set Makers' Surplus, sealed cartons, guaranteed; all goods carriage paid; cash with order or c.o.d.

**M**OVING Coil Speakers.—Magnavox, 1933, type D.C.144, 2,500 or 6,500 ohms, listed 40/-, and 42/6, at 19/- each; type D.C.143, same voltages, listed 50/- and 52/6, at 26/- each; state if power or Pentode transformer; Rola's K type U.S.A. Junior 7 1/2 cones, 2,000, 2,500, or 6,500 ohms at 18/-; Seniors, 9in. cones, same voltages, at 25/- each. Also number permanent magnets, with 7 1/2 and 9in. cones, few duals and class B coils (3 each only), Ferrocart F.1, F.2, and F.3, or G.1, G.2, and G.3, at 32/- per set, ganged with switching; (300 only) specified coils for the S.T.400, 27/6; (200 only) Eton dual iron cored coils in cans, theoretical circuit enclosed for different circuits, at 5/- each; pick-ups, few only: 1933 Seniors, Marconiphone, 28/-; B.T.H., 2 guineas model, 28/-; Harlie, complete with volume control, list 27/6 at 15/-.

**S**MOOTHING Condensers: 800 test, 250 a.c. working, 1 mfd., 1/1; 2 mfd., 1/9; 4 mfd., 2/6; 1,500 test, 500 A.C. working, 1 mfd., 1/9; 2 mfd., 2/4; 4 mfd., 4/-; multiple banks, all separate tappings, 1,500 test, 5 mfd., 2+2+1 mfd. at 4/6, 11 mfd. 4+2+2+2+1 mfd. at 6/9, 20 mfd. 2+2+2+2+2+2+2+2+1+1 mfd. at 11/- each.

**V**ARIABLE Condensers, all complete in sealed cartons, with covers, light, escutcheon, knob trimmers, disc drive etc.: J.B. Nu Gang 2-gang, 9/6; 3-gang Nu Gang at 17/-; Polar Star 1933, 3 Star (ordinary), 17/-; Star (Super Het) at 17/-; Polar Star, 1933, Minors, 3-gang (ordinary), 16/-; 3-gang (Super Het) at 17/-; 2-gang at 10/-.—Chal Electric, No. 6, Conduit St., London, W.1.

**GILBERT INDUSTRIES** Parcels and Components.—"A," "B" and "D" parcels still available by return (see issue October 6th).

**O**UR Famous 30 m.a. 180v. A.C. Eliminator Kit, complete in every detail, has now been redesigned with a still smarter case and heavier rectifier; price remains at 30/-, post paid, while supplies last.

**GILBERT INDUSTRIES, Ltd.**, 519, London Rd., West-cliff, Essex. Phone: Southend 492071. (Come and see us Sunday morning.) [0402]

**T**WO Complete Portable Talkie Outfits, made by Associated Sound Equipments, sound on film, can be seen and heard working at the below address.

**F**OR Further Particulars of the Above Equipments, also variety of pull-through and driven soundheads, first stage amplifiers, main amplifiers, P.A. amplifiers, photo cells, etc., apply for lists.

**H. FRANKS**, 42a, St. George St., Commercial Rd., London, E.1. Phone: Royal 8546. [4003]

**3**D. per Week Secures Hamill's Patent Valve and Radio Tester: 1/- down, 3 monthly payments of 1/-.—Hamill, 23, Bede Crescent, Willington-on-Tyne. [3990]

**T**RADERS, save time, order from the house who still specialise in kits and components, all kinds; catalogue 6d.—Perseus Radio, W.W., Burton-on-Trent. [0410]

**FERRANTI** B2 Choke, 14/-; Ferranti A.F.7, 18/6; 2 Ferranti anode lead units, 2/6 each; R.I. pentamite choke, second-hand, 12/6.—24, Rookery Rd., Bristol. [4049]

**CINEMATOGRAFI** Projectors, optical lanterns, films, slides, projection bulbs, lenses, spotlights; your inspection invited of big selection of bargains too numerous to list.

**I**LLESTRA ENTERPRISES, 159, Wadour St. (facing Film House), London, W.1. Phone: Gerrard 6889. [3750]

**A**MATEURS' Mikes, amplifiers, short wave transmitting, receiving; write lists: A.F.5 c.c., 17/6; A.F.5 c.s., 20/-; A.F.5, 14/-; O.P. c.25, 9/-; D.O.25s, 15/-.—Gardner, The Rock, Birehlington, Kent. [4041]

**FERRANTI** O.P.M.1, 9/-; O.P.M.1c, 10/-; O.P.M.2c, 10/-; A.F.5c, 15/6. Varley double tapped secondary P.P. transformer, 15/6. Macnamara walnut cabinet, 8/6; all goods guaranteed.—Wiggan, 14, Bent St., Brierley Hill, Staffs. [4076]

**MARCONI** Eliminator, D.C.7, 180v. 60 m.a., 30/-; A.M.7 H.T. and L.T., with valve, 65/-; Ekco D.C. 150v. 20 m.a., 12/6; Magnavox D.C.143, 7,500 ohms (3 ratio), 27/6; Ferranti A.F.15c. new 20/-; all perfect.—72, Howard Rd., E.17. [4080]

**S**EE Modern Radio's advert, in last week's issue for some of the Best Bargains in These Columns. On page 21, top left hand corner. This week we offer ex R.A.F. smoothing condensers, all tested before despatch, tested to 4,000 volts D.C. working, voltage 2,000. 6/6 each.

**A** FEW Fay Microphones Still Available, complete with stand, transformer and battery, a very sensitive model, with 3-point spring suspension, all new and boxed: 18/9.

**F**AY Acoustic Model Home Recorders, new and boxed, complete with cutting needle, and tracking arm. 5/6; records for same, 5/- per dozen.

**A**LL Goods in Perfect Order; despatched post free and by return.—Modern Radio, 25, York Terrace, Clapham, S.W.4. Callers only to Modern Radio, 37, Lisle St., Leicester Sq., W.C.2. [4079]

**X**-RAY Equipment: sixteen inch X-ray coils, 50/-; Mercury breaks, with D.C. motor drive, 50/-; X-ray control switchboard, in large oak case, £4; Diathermy outfits, £4; complete X-ray set, including switchboard, coil, motor driven, mercury break fittings, etc.; £10.—Below.

**T**WO-INCH Spark Coils, 17/6; one-inch, 6/6; G.P.O. wall telephones, magneto ringing, 12/6; microphones, 4/6, 2/6 and 1/-; microphone transformers, 2/6; and other telephone gear.—Below.

**W**HEATSTONE Bridge with Unipivot Galvanometer, £3/10; Unipivot galvanometer, 15/-; silvertower galvanometer, 5/-.—Below.

**C**HARGING Resistances, any voltage, 15/- each; shunt regulators, 12/6; ampere, 0-3, 7/6; 0-20, 12/6; and others, all large sizes.—Below.

**C**HARGING Dynamos, all sizes in stock; state requirements; motor driven pumps, 110 or 220v. D.C., 35/- each; large short wave transmitting coil in case, size 16in.x16in.x8, also fittings, 12/6, carriage paid.

**P**ORTABLE Acetylene Gas Lamp, complete in case, 30/-; 2 ml. condensers, 1/-; mine exploders, plunger type, 30/-; new 1 k.v. transformers, 110v. input, 10,500v. output, 25/-; 2,000v. generator, 100v. field excitation, £2/10; 3-valve amplifiers for microphone work, 8/-; also large selection of miscellaneous gear; visitors welcome.—Below.

**G**ALPIN, 31, Bonfield Rd., Lewisham, London, S.E.13; works and stores, rear of 14, Loampit Hill, S.E.13; all correspondence to private address; all goods cash with order or c.o.d.; all goods guaranteed; visitors welcome; fine selection. [4064]

★ Specified  
**EXCLUSIVELY**  
for the "Wireless World"

**A.V.C. STRAIGHT**  
**4**  
QUALITY SET

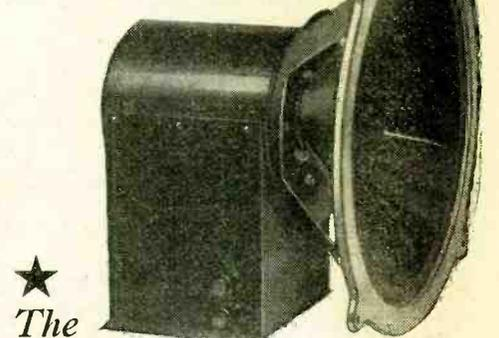

★ The **BAKER** SUPER POWER £6

The Ideal Reproducer for the Connoisseur:

This fine S.P.D. Reproducer, known to thousands of 'Wireless World' readers, and famed the world over for its unequalled realistic reproduction, has been selected and specified exclusively by the 'Wireless World' for their A.V.C. 'Straight 4' Quality Receiver. Your usual dealer will be happy to supply you.

Ideal for the Experimenter

The 'justone' is the greatest advance in modern Speaker design for experimenters, possessing as it does, scientific impedance matching plus variable tone control. Any output can be matched accurately, including Class 'B' and Q.P.P. Price, as illustrated, only **45/-**



Ideal for use as an Extension

This latest addition to Baker quality reproducers is designed especially to match the output of 36 modern commercial receivers. It can be used as a microphone, is preferred by motorists for car radio, and makes an ideal Christmas Present. Price, with Cabinet, tone control, and on/off switch, only **29/6**

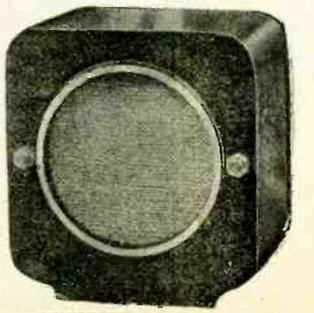

**BAKER**

The Pioneer Manufacturers of Moving Coil Reproducers

Baker Selhurst Radio, 75, Sussex Road, South Croydon, Surrey. Phone: Croydon 3441.

YOU NEED THEM—because they are better

# ERIE RESISTORS

SPECIFIED and used by the designer

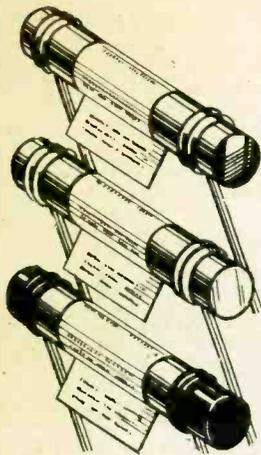

FOR THE  
"A. V. C.  
STRAIGHT  
FOUR"

All the 18 Resistors for this are specified **ERIES**. You need Eries for best results. That's why the manufacturers use them and why they are specified and recommended for all the foremost sets.

★ NOTE!!  
ERIE RESISTORS are specified throughout The BRITISH RADIOPHONE "MATCHED PERFECTION 7"

## ERIE

1/- PER WATT in all Values.  
All colour coded and labelled.

## IMPREGNATED RESISTORS

### The Reasons

- Eries have the lowest noise level of any resistors made.
- They are the only fully impregnated carbon resistors—which gives them stability.
- They have practically no voltage or temperature coefficient.
- They are non-inductive, non-capacitative, and Guaranteed against breakdown.

Furthermore, Eries are economical.

POST FREE!!

Eric Colour Code Chart and technical data Folder. Everyone who wants better results should have it. Write to:—

THE RADIO RESISTOR CO.

1, Golden Square, Piccadilly Circus, London, W.1.

**ELIX**  
CHEAPEST PERFECT CONTACT



Specified and Essential

FOR THE

"A.V.C. STRAIGHT FOUR"

Four 5-pin chassis mounting STANDARD Model 9d. each

One 7-pin FLOATING Model 1/-

AND FOR THE POWER UNIT

Two 5-pin chassis mounting STANDARD Model 9d. each

Obtainable from ALL Dealers. Descriptive Folder "W" Free.

**LECTRO LINX Ltd.,**

79a, Rochester Row, London, S.W.1.

Telephone: Victoria 3541.

Specified for the  
"A.V.C. STRAIGHT 4"

SAVAGE I.F. SMOOTHING CHOKE

**R.C27M Price 28/-**

(as specified)

SAVAGE MAINS TRANSFORMER, SPECIALLY DESIGNED FOR "A.V.C. STRAIGHT 4."

Type A.V.C S4. Primary: 200 to 250 volts, 50 cycles; secondaries: 450-0-450 volts, 120 mA. 4 volts 2.5 amp. centre-tapped; 4 volts 5-6 amp. With screened primary - - - **43/-**

Complete Power Pack

Assembled and Ready for use

**£6-6-0**

# SAVAGE

**MAINS TRANSFORMERS**

56 58, CLERKENWELL ROAD, E.C.1

'Phone: Clerkenwell 3068/9.

Components, etc., for Sale.—Contd.

**EPTON Leads Again!**—Simpson's electric turntables, 200-250 A.C., 12in. turntables, brand new (listed 39/6), 25/6; T.C.C. electrolytic condensers, 2,000×2,000 mfd., 12v. working (listed 27/6), 5/6; R. and A. output transformers, multi-ratio, 32-1, 25-1, 18-1, power/pentode, 6/6.—Epton, 93, New Rd., Chingford, E.4. [4088]

**CHASSIS.**—Guaranteed A.C. or D.C. 2-valve chassis, completely wired, with all components, disc drive, dial light, etc.: A.C., 200-250 volt. 29/6; D.C. ditto 28/-; with Telsen iron-core coils, 33/- and 31/6 carriage paid. Class B units to modernise your Skyscraper or other battery set, complete with matched moving coil speaker, driver and output transformer, valve, all wired and tested, with instructions. 59 6 Mains Radio Development Co., 4-6, Muswell Hill Rd., London, N.6. [4073]

**AMPLIFIER.** Phillips A.C. mains, 10 watt stage, complete with mains transformer, intermediate transformer, choke, bias, smoothing, etc., with rectifying and 400 volt D.O.26 super power valves in metal case; when coupled to speaker terminals of small battery or mains receiver will deliver undistorted output of 7 to 8 watts, suitable for dances, parties, cafes, etc.; cost £12/10, accept £3/7/6; also 3-watt output size, accept £2/10; state voltage required.—Johnson Engineering, 86, Great Portland St. [4048]

**NEW Radio Surplus,** all post free.—Radiophone 4-gang condensers, straight type, split vanes and trimmers, 8/9; Tritron 8 mfd. wet, 2/11; H.M.V. 4×4 mfd. condenser blocks, 3/6; 250v. working T.C.C. 0.01 mica, type M, only dozen lots, 4/9; T.C.C. 0.0005 mica, type M, only dozen lots, 2/6; Polar Star Major 3-gang 14/-; Magnavox D.C.144, with transformer, 2,500 ohms, 16/-; R. and A. type output transformers, 18/23/32-1, 4/9; Pye 20H and 32H chokes, new, 4/9.—Bell, 77, Badminton Rd., London, S.W.12. [3935]

**CLASS "B" COMPONENTS.**

**SOUND SALES, Ltd.,** for Class "B" Components. List "B.B." on request.—Tremlett Grove, Highgate, N.19. [4041]

**COMPLETE Class B Components;** 2 Cosmor valves, transformer and Celestion matched P.M.19 speaker, as new; 40/-.—Box 8719, c/o The Wireless World. [4081]

**MISCELLANEOUS.**

**WIRELESS Notes.**—A unique news and information service, now starting its sixth year; useful to thousands, you can't afford to be without it; postcard for full particulars, to Robinson, "Langmead," Pirbright, Woking. [4063]

**EASY Payments.**—We supply, by easy payments, components, accessories, and sets, any make; 10% down, balance spread over 11 months.—Send list of requirements to London Radio Supply Co., 11, Oat Lane, London, E.C.2. [0337]

**ENGINEERS and Technical Workers of All Kinds.**—A proper training by post in your spare time will take you through your right examination, the employment is waiting. Our advice on all careers free.—Dept. 92, The Bennett College, Ltd., Sheffield. [0395]

**AMBITIOUS Men.**—Quality for a well-paid post by studying at home with the T.I.G.B. Write to-day for "The Engineer's Guide to Success," 144 pages, free, which contains the widest selection of engineering and wireless courses in the world, and shows you how to become A.M.I.E.E., A.M.I.Mech.E., A.Rad.A., etc. State branch, post, or qualification that interests you.—The Technological Institute of Great Britain, 82, Temple Bar House, London, E.C.4 (Founded 1917. 19,000 successes.) [3869]

**LABORATORY CALIBRATION.**

**CALIBRATION of Apparatus at Modified Rates to Amateurs** is now conducted by a special section of Paul D. Tyer's laboratory; applications by letter only to: 28, Victoria St., London, S.W.1 [0406]

**PATENT AGENTS.**

**A. MATHISEN, B.Sc.,** Patent Agent and Consulting Electrical Engineer, First Avenue House, High Holborn, London, W.C.1. Holborn 6950. [3496]

**PATENTS and Trade Marks, British and Foreign.**—Gee and Co. (H. T. P. Gee, Member R.S.G.B. and A.M.I.R.E.), 51-52, Chancery Lane, London, W.C.2. 'Phone: Holborn 1525. [0001]

**REPAIRS.**

**SERVICING to Any Set, British or American;** highest workmanship only.

**SPECIALIST in the Manufacture of Amplifying Equipment** of any output, also mains, superheterodyne receivers.

**L. EASTWOOD, Radio Manufacturers Consultant,** late of His Master's Voice and Marconi's Wireless Telegraph Co. 'Phone: Clerkenwell 7693. Address: 70, Pittfield St., Great Eastern St., N.1. [0404]

**LOUDSPEAKERS, transformers, any make, promptly and efficiently repaired;** 3/6; satisfaction guaranteed.—Breeze, Clapper House, Marden, Kent. [4057]

**METROPOLITAN RADIO SERVICE Co. Specialise in Repairs, British and American radios; transformers rewound.**—1021, Finchley Rd., Golders Green, Speedwell 3000. [3992]

**PHONES, speakers, transformers repaired, 4/-, post free;** mains transformers and all coil winding quotations.—Electrical Depot, 70a, Exmouth Rd., Walthamstow, E.17. [4055]

**HENRY FORD RADIO, Leading Service Specialists for American receivers, also British, trade work particularly; estimates free.**—56, Howland St., Tottenham Court Rd., W.1. Museum 5675. [4077]

**REWINDS of All Descriptions; mains transformers, chokes rewound or converted, any specification; m/cs., inductors quoted; pick-ups, 3/-; L.F. transformers, 3/-; loudspeakers, 3/-; twelve months' guarantee; 24 hours' delivery.**—Graham's, 208, High St., Tooting, London. [4085]

**GUARANTEED Repairs by Experts, specialists for repairs to S. G. Brown and Ampliton radio apparatus, also loud speakers, headphones, pick-ups, Blue Spots, any type rewound, remanufactured and adjusted, 4/-; post free; mains transformer repairs; terms to trade.**—Howell, 91, Morley Hill, Enfield, Middlesex. [9716]

**Repairs.—Contd.**

**REPAIRS** to Loud-speakers, transformers and headphones 4/-; Blue Spots or Wufas, 5/-, post free; moving coils a speciality, new cones fitted; eliminators and mains transformers quoted for; prompt service; satisfaction guaranteed; discount to trade.—Loud Speaker Repair Works, 5, Balham Grove, London. Battersea 1321. [0394]

**TUITION.**

**QUALIFIED** Radio Engineers are Always in Demand, and our Home Study Course will enable you to qualify for a good post; many students already placed this season; prospectus free.—Northern Counties Wireless School, Preston. [0399]

**EXCHANGE.**

**EXCHANGE** Your Old Set or Components for New, best allowance.—Radio Exchanges, 114, Ramuz Drive, Westcliff-on-Sea. [4062]

**DEAL** With the Firm that Gives You the Highest Possible Allowance in Exchange; sets or components; prompt attention and deliveries.—Midmay Radio Exchange, Phone: Clissold 5001. 24, Midmay Grove, London N.1. [3658]

**HIGH** Allowances Made on Second-hand Goods in Part Payment for New Sets or Components; easy payments available; we have tremendous stocks tested second-hand goods; send list of your requirements for quotation.—Bostock and Stonnill, 1, Westbourne Terrace, S.E.23. [4056]

**WANTED.**

**MONODIAL** 5-watt 200v. A.C.—Box 8714, c/o The Wireless World. [4051]

**GAMBRELL** "Novotone," type J; state price.—Clark, 115, Menock Rd., Cathcart, Glasgow. [4044]

**WANTED**, 5-valve superhet. chassis; London; replies only required.—BM/NKBM, London W.C.1. [4058]

**SPOT** Cash for Components, sets, etc.; any quantity.—Economic Radio Co., 96-98, South Lambeth Rd., S.W.8. [4075]

**ROTARY** Transformer, urgent, for P.A. outfit, input 12v., output 300v., 160 ma. approx.; price reasonable.—Arcade Wireless Stores, Middleton, Manchester. [4036]

**NEW** or Second-hand Sets, kits and parts bought, sold, exchanged; best exchange allowances; lots of first class second-hand goods in stock.—R. Wigfield, Furlong Rd., Goldthorpe, Yorks. [4054]

**WANTED**, good modern second-hand wireless parts, sets, meters, eliminators, speakers; we pay higher prices than any other dealer; bring or send, spot cash. Open 9-8.—University Radio, 142, Drummond St., Euston N.W.1. [4031]

**HIGH-CLASS** Radio Parts and Sets Wanted for cash, new or second-hand, any quantity; send yours stating reasonable price; cash by return; retailers' stocks purchased.—Midmay Radio Exchange, 24, Midmay Grove, London, N.1. Phone: Clissold 5001. [3455]

**FINANCIAL PARTNERSHIPS.**

**PARTNER** Wanted Radio Business, retail; repairs; opening Edgware Road.—Write Taylor, 60, Burnley Rd., N.W.10. [4037]

**SITUATIONS VACANT.**

**YOUNG** Men Trained for all Branches of the Wireless Profession in Britain's Leading College; training fee can be paid after appointment secured; students accepted as boarders; London representative available for interviews. Prospectus free.—The Wireless College, Colwyn Bay. [0388]

**A PHYSICAL** Chemist Required for Research Work in Connection with Wireless Valve Manufacture; applicants should either have experience in this industry, or possess a sound knowledge of thermionics and vacuum technique; applications will be considered only from those with one or both of the above qualifications.—Reply by letter, stating qualifications, experience, age and salary required, to Lissen, Ltd., Worpole Rd., Isleworth, Middx. [4060]

**SITUATIONS WANTED.**

**EXPERIENCED** Mechanic and Operator, ex public school, wireless experience since 1920, design, construction, installation and maintenance of high and low frequency transmitting and receiving plant of medium and low power, direction finding and short wave broadcast reception; is returning to England in December after five years in the East; offers his services wherever a knowledge of tropical and sub-tropical communication requirements would be of value.—Box 8572, c/o The Wireless World. [3921]

**BOOKS, INSTRUCTION ETC.**

**BACK** Issues "Experimental Wireless," "Wireless World," etc., for disposal.—BM/ZLME, W.C.1. [4043]

**AUCTION SALES.**

**OLD SWAN, LIVERPOOL.**  
AT A LOW RESERVE.

re **LOTUS RADIO, LTD.**, IN LIQUIDATION.  
BY ORDER OF THE JOINT LIQUIDATORS,  
W. T. Wood, Esq., and Frederic C. Marsh, Esq.,  
TO BE SOLD BY AUCTION BY

**BOULT, SON & MAPLES.**

on Friday, December 1st, at 2.30 p.m., at THE PROPERTY EXCHANGE, 14, Cook Street, Liverpool. (Unless sold privately).

**LOTUS WORKS, MILL LANE,**

Modern Freehold Factory erected in 1929, of Brick Construction, with North lighted roofs. Total Floor Space over 35,000 feet super, together with adjoining Freehold land suitable for extension purposes.

**TOTAL AREA ABOUT 10,791 Sq. Yds.**

Central Heating, Gas Water and Electricity laid on. Vacant possession. Full particulars from W. T. Wood, Esq., Messrs. Lewis and Mounsey, Chartered Accountants, 3, Lord Street; Frederic C. Marsh, Esq., Messrs. Cooper Brothers and Co., Chartered Accountants, 3, Rumlford Street; Messrs. Bartley, Cocks and Bird, Solicitors, 17, Sweeting Street; or the Auctioneers, **BOULT, SON and MAPLES**, Estate Agents, 5, Cook Street, Liverpool.

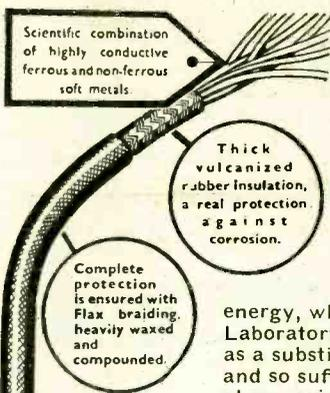

**SUPERIAL is definitely the BEST AERIAL**

The resistance offered by SUPERIAL to incoming signals is negligible because of the unique surface or skin of each strand. All-copper aerials, particularly those covered with cotton, after exposure to the air become oxidised, resulting in a definitely increasing resistance to the incoming waves of energy, which should not be confused with the ordinary electric current. Laboratory tests definitely prove this. Other aerials are being offered as a substitute for SUPERIAL. Do not be misled by extravagant claims and so suffer disappointment. SUPERIAL is the best aerial obtainable at any price and every coil is sold under a full guarantee of satisfaction.

**FREE £500 LIGHTNING INSURANCE FOR 2 YEARS**

**SUPERIAL**  
THE AERIAL WHICH MADE BROADCASTING POPULAR  
ELECTRON'S SUPER-AERIAL

100 FT. 3/6 75 FT. 2/6 50 FT. 1/9 25 FT. 1/-  
From Dealers everywhere or direct.

**MAKE YOUR SET SUPER-SELECTIVE**

VARIABLE is a marvellous invention which will give aeriels every desired degree of selectivity, cutting out interference from other stations. Can be used with any set on any aerial. Fixed in a few moments and requires no alterations. Can be supplied already attached to a coil of SUPERIAL—the only self-contained variable aerial.

**1/6 EACH**

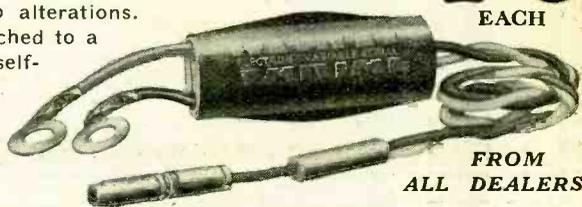

100 ft. 75 ft. 50 ft.  
**4/6 3/6 2/9**

In this form it is the world's most selective aerial.

FROM ALL DEALERS

**ELECTRON INSULATOR PINS FOR INDOOR AND INVISIBLE AERIALS**

Fix one little ELECTRON INSULATOR PIN on each corner of the room and run a proper wire aerial (SUPERIAL) through them. The only efficient indoor or invisible aerial properly insulated and kept away from the walls. Three colours, OAK, MAHOGANY, BLACK, in boxes of six for 6d.

**6 D. PER BOX OF SIX**

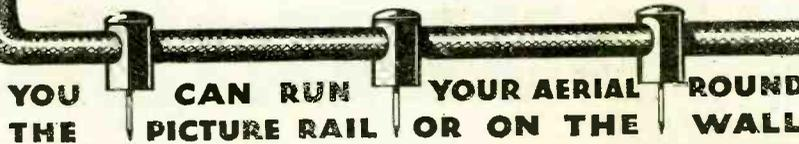

**YOU CAN RUN YOUR AERIAL ROUND THE PICTURE RAIL OR ON THE WALL**

All the above Electron lines can be obtained from any Wireless shop or direct from:—

**The NEW LONDON ELECTRON WORKS Ltd.**  
92 EAST HAM LONDON. E.6

Telephone: Grange Wood 1408-9-1363.

Telegrams: Stannum, London.



**SPECIFIED FOR THE "W.W." A.V.C. STRAIGHT FOUR**

BRYCE MODEL A.B. 573/3 TRANSFORMER.

**ENSURE THE CONFIDENCE OF THE DESIGNER**

Complete Kit of 18 Super Precision, Vitreous Enamel METALLISED RESISTANCES. Price 17/6  
L.F. SMOOTHING CHOKE Price 19/6.

Best Quality Materials, subject to 10,000 v. Insulation Test, and 4 Independent Meter Tests, Low Magnetising Current. GUARANTEED 5 YEARS.

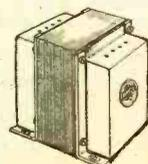

Price 50/-

**W. ANDREW BRYCE & CO., Woodfield Works, BURY, Lancs.** Phone: 1251.  
LONDON AREA—Wilburn & Co., Wheatsheaf House, Carmelite Street, LONDON, E.C.4.

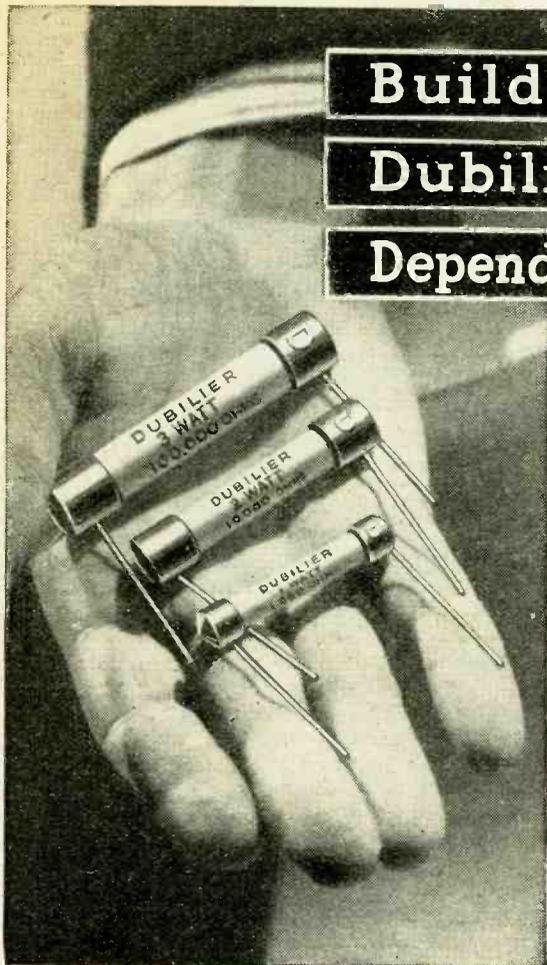

**Build with  
Dubilier for  
Dependability**

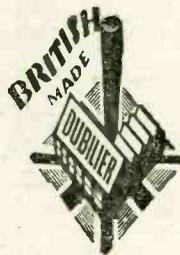

Tests carried out have proved that the life of Dubilier Metallised Resistances is practically limitless. Thousands of hours of service have failed to alter their value even by as little as 1%. You cannot buy a better Resistance than Dubilier. Their special method of manufacture, exhaustive testing and *proved* performance are a guarantee that they will never fail you.

1 Watt 1/-  
2 Watt 2/-  
3 Watt 3/-

**DUBILIER**

**\* R E S I S T A N C E S**

DUBILIER CONDENSER CO. (1925) LTD., DUCON WORKS, VICTORIA ROAD, N. ACTON, LONDON, W.3

# RADIO DATA CHARTS

A  
SERIES OF ABACS

providing most of the essential  
Data required in Receiver Design

By  
R. T. BEATTY, M.A., B.E., D.Sc.

*Reprinted from  
"The Wireless World"  
(1930)*

"Radio Data Charts" provide designers of wireless apparatus with a ready and convenient means of solving problems without having recourse to complicated formulæ and mathematics.

By the use of the charts it is possible to tackle all the more familiar problems in radio receiver design, such as, for example, finding the relationship between inductance capacity and frequency, and working out the design of high frequency transformers. All keen amateurs will appreciate this helpful book.

(39 CHARTS and more than  
50 Diagrams)

Price 4/6 net  
By post 4/10

Published from the Offices of  
"THE WIRELESS WORLD"

From all leading booksellers or direct  
from the Publishers

**ILIFFE & SONS LTD.**  
Dorset House,  
Stamford St., London, S.E.1

W.W.93

Single Terminals  
Superseded

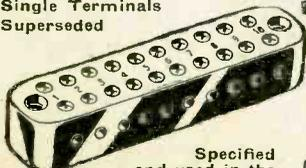

Specified  
and used in the  
**A.V.C. STRAIGHT FOUR.**

Made of superior bakelite with moulded-in brass insets, numbered, with screws well sunk below surface of bakelite. Specially suited to mains-operated receivers. Shockproof and compact. Send for illustrated catalogue of Terminals, Blocks and Peak Condensers.

**WILBURN & COMPANY**

Wheatsheaf House, Carmelite St., E.C.4  
Phone: Central 6810.

**INSULATED  
TERMINAL  
BLOCK**  
5-WAY 2/6 each.  
6-WAY 2/9 each.  
10-WAY 3/6 each.

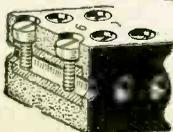

## OPENINGS for ENGINEERS!

Never before has engineering offered such magnificent chances. With the rise of the depression, the industry is literally teeming with first-class opportunities. Our 250-page Hand-book "ENGINEERING OPPORTUNITIES," shows where the opportunities lie, and the easiest way to prepare for them. The Hand-book gives details of A.M.I.Mech.E., A.M.I.E.E., A.M.I.C.E., G.P.O., etc. Exams, outlines Home-Study Courses in all branches of Civil Mech., Elec., Motor, Radio & "Talkie," Engineering, Building, etc., and explains our

**FREE!**  
**250**  
**PAGES**

unique Employment Dept. Send for this valuable Hand-book to-day — FREE! BRITISH INSTITUTE OF ENGINEERING TECHNOLOGY 387, SHAKESPEARE HOUSE, 29, OXFORD STREET, LONDON W.1.

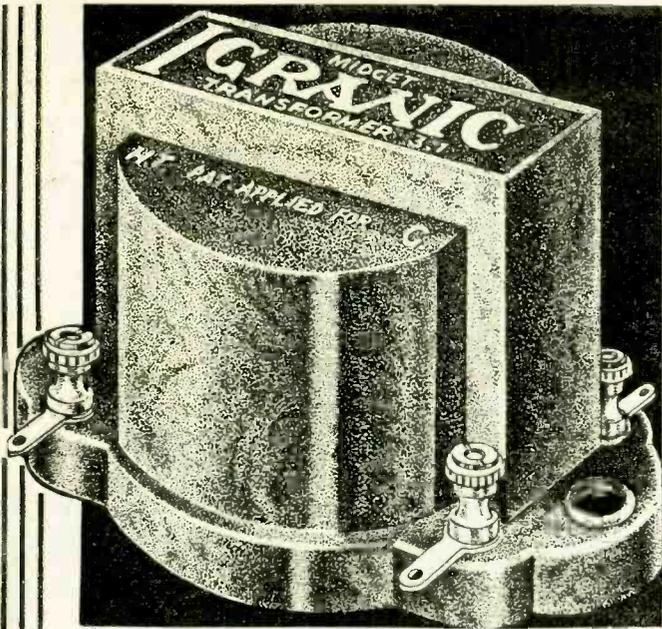

Igranic have specialised in Transformer manufacture since the inception of Broadcasting, and many years of experience and costly research have led to the production of the "Midget" Transformer. Its reproduction reaches a standard never previously attained by a Transformer of such reasonable price. In ratios 1-3 and 1-5. Price **8/6**

Write for fully illustrated Catalogue No. U.358 of Igranic Quality Components.

**IGRANIC ELECTRIC CO. LTD.,**  
149, Queen Victoria Street, E.C.4.

CVS-102

## Why is GROSVENOR the longest-lived battery in the World?

*Firstly . . .* The zinc cells are the cause of 99% of battery failures. By the Grosvenor MERCURY process, these vital cells are guarded—scientifically protected against corrosion and deterioration.

*Secondly . . .* So long do these MERCURY-protected cells last that Grosvenor fill them with extra chemicals to use them up. Every Grosvenor battery is crammed to the limit with this abundant extra long-lived power.

That is why it is no idle claim, but a scientific certainty, that Grosvenor are the longest-lived batteries in the world—the batteries that give you more for your money. Insist on Grosvenor next time, and test this for yourself!

**NEXT TIME  
PLUG INTO  
THE BATTERY-**

GROSVENOR Mercury Batteries are made for every Radio need, from 5/6 to 20/-. Ask also for Grosvenor Miscan-lite Electric Torches, strong and attractively coloured, from 1/-.



**-THAT GIVES  
YOU MORE**

**GROSVENOR ELECTRIC BATTERIES LIMITED,**  
2-3 White Street, E.C.2. Telephone: METropolitan 6866 (3 lines).

*For the Trade only.*

# NOW READY!

## THE 1934 'TRADER' YEAR BOOK & DIARY.

To every progressive trader the 1934 "Trader" Year Book is indispensable. This year we have doubled the page size to accommodate the new and enlarged sections and to give more space to the business entry and Diary section. But there is no extra charge for this bigger 1934 Year Book.

The following are the eight main sections. They are each printed on various tints of paper.

1. A comprehensive section dealing with legal, technical and licensing information, service and workshop data.
2. An enlarged section which gives specifications of all the well-known 1933-4 Receivers.
3. Diary section—one week at view.
4. Classified Buyers' Guide.
5. Trade and Professional Addresses.
6. Alphabetical list of factors.
7. Territorial list of factors.
8. Alphabetical list of Proprietary Names.

A practical and really useful Encyclopædia of up-to-date Trade information that should be on the desk of every keen and enterprising trader.

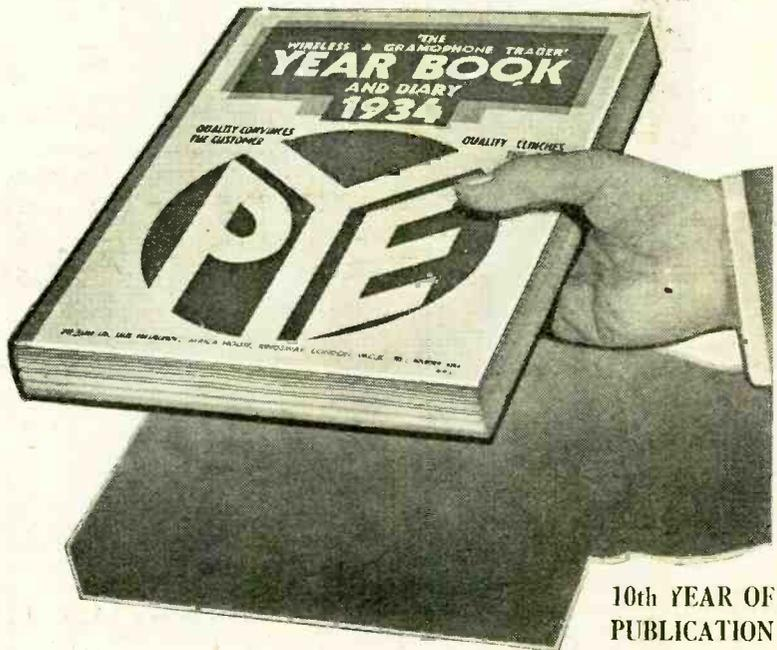

**BIGGER AND  
BETTER THAN EVER!**

**5/6** POST FREE.

Special reduced rate for Postal Subscription to 52 issues of "The Wireless & Gramophone Trader" (10/6) and "The Year Book" (5/6), inclusive price 14/-.  
14/-.

Orders are dispatched in strict rotation, so send your order in *now* and be sure of your copy.  
Send remittance to:  
**"THE WIRELESS & GRAMOPHONE TRADER YEAR BOOK & DIARY."**  
DORSET HOUSE, STAMFORD ST., LONDON, S.E.1.

INDEX TO ADVERTISEMENTS.

Automatic Coil Winder & Elec. Equipment Co., Ltd. .... 19	Epoch Radio Mant. Co., Ltd. .... 17	Peto-Scott Co., Ltd. .... 14
Baker's "Selhurst" Radio ..... 19	Ever Ready Co. (Great Britain), Ltd. .... 4	Pickett Bros. .... 18
Baxter, Stavridi & Craies, Ltd. (Apollo) ..... 19	Exide ..... Back Cover	Postlethwaite Bros. .... 16
Benjamin Electric, Ltd. .... 19	Fel-Etric Radio ..... 16	Radio Resister Co. .... 20
Black, Alexander, Ltd. .... 24	Ferranti, Ltd. .... 7	Radio Service (London), Ltd. .... iii.
British Blue Spot Co., Ltd. .... 8	General Electric Co., Ltd. .... Inside Front Cover	Reproducers & Amplifiers, Ltd. .... 18
British Inst. of Eng. Technology ..... 22	Grosvenor Electric Batteries, Ltd. .... 23	Riverside Mant. Co., Ltd. .... 10
British Mains Units Co. .... 16	Hartley-Turner Radio, Ltd. .... 16	Savage, W. Bryan ..... 20
British Radio Institute ..... 16	Haynes Radio ..... 13	Scientific Development Co. .... 18
British Radiophone, Ltd. .... 9	Hellekens, Ltd. .... 11	Standard Telephones & Cables, Ltd. .... 16
British Rola Co., Ltd. .... 15	Hill, M. L. .... 24	Stratton & Co., Ltd. .... 10
Bryce, W. Andrew, & Co. .... 21	Igranic Electric Co., Ltd. .... 23	Tannoy Products ..... 18
Bulgin, A. F., & Co., Ltd. .... 1	Lectro Linx, Ltd. .... 20	Telephone Manufacturing Co., Ltd. .... 2
Burton, C. F. & H., Ltd. .... Front Cover	Lever, Eric J. (Trix), Ltd. .... 16	Telsen Electric Co., Ltd. .... Front Cover
Carrington Manfg. Co., Ltd. .... 24	Luman Electric Co. .... 16	Trader Publishing Co., Ltd. .... 23
City Accumulator Co., Ltd. .... 6	Macindoe & Co. .... 16	Varley (Oliver Pell Control), Ltd. .... 16
Colvern, Ltd. .... Front Cover & 6	Mains Power Radio ..... 24	Watmel Wireless Co., Ltd. .... 18
Concordia Electric Wire Co., Ltd. .... 18	Metropolitan Vickers Electrical Co., Ltd. .... iv.	Westinghouse Brake & Saxby Signal Co., Ltd. .... Inside Back Cover
Cossor, A. C., Ltd. .... 12	New London Electron Works, Ltd. .... 21	Whiteley Electrical Radio Co., Ltd. .... 22
Dubilier Condenser Co. (1925), Ltd. .... 5 & 22	Ormond Engineering Co., Ltd. .... 6	Wilburn & Co. .... 13
Edison Swan Electric Co., Ltd. .... 3, Inside Back Cover	Ostar Ganz (Eugen Forbat) ..... 24	Wilkins & Wright, Ltd. .... 11
Electradix Radios ..... 16	Partridge & Mea, Ltd. .... iii.	Wingrove & Rogers, Ltd. (Polar) ..... 4
	Pepper, Trevor ..... 24	Wright & Weaire, Ltd. .... 2

# OSTAR-GANZ

## UNIVERSAL MODEL SETS

One set for both D.C. or A.C. Work on any Mains supply without alteration. Quality British components used throughout. Ferrocart coils. Polar. Ferranti. Dubilier. Varley. British Radiophone. Magnavox m.c. speaker. Garrard all-electric motor, etc. Ostar-Ganz Universal High Voltage Valves. Hire Purchase terms arranged. State Voltage when ordering. Full particulars in Model Set Leaflet "W.S."

"HIGHMU 3" 9 Gns. "HIGHMU 4" 12 Gns.  
 UNIVERSAL 5 v. SUPER 15 Gns.  
 UNIVERSAL 7 v. STENODE SUPER. All 15 v. valves, 25 Gns.  
 UNIVERSAL RADIOGRAMS, 3 v. 17 Gns. 4 v. 19 Gns.

### KITS That work from either A.C. or D.C. mains.

<b>RECEIVERS</b>	
Universal "HIGHMU 3" Kit .....	£8 5 0
Universal "HIGHMU 4" Kit .....	£8 15 0
Universal "5 valve SUPER" Kit .....	£11 11 0
Universal "7 valve STENODE SUPER" .....	£15 15 0
<b>RADIOGRAMS</b>	
Universal 3 valve Kit £10 10 0, 4 valve .....	£12 12 0
<b>AMPLIFIERS</b>	
Universal 2 valve £5 5 0, 3 valve £7 7 0	

All prices include Ostar-Ganz High Voltage Mains Valves, all components, full size lay-out, building instructions. Full technical assistance if desired. (Send for detailed list of Kits.)

**EUGEN J. FORBAT**  
 28-29, Southampton St., Strand, London, W.C.2  
 Phone: TEMple Bar 8608.

### SERADEX RESISTORS

as specified for "A.V.C. Four."

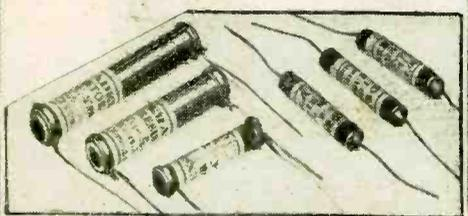

KIT OF 18 RESISTORS 11/4 POST FREE.  
 Send for Lists.  
**TREVOR FEPPER, 575, Moseley Road, BIRMINGHAM.**

**FOR HIRE FULLY EQUIPPED VAN**  
**PUBLIC ADDRESS VAN**  
 Sent anywhere in British Isles, also RADIO, MICROPHONE, & GRAMOPHONE AMPLIFIERS giving exceptional quality and volume, suitable for Dances, Sports Meetings, Poles, etc. from 15/- per day.  
 McUl-hael Portable Sets 15/- a week, £2-12-6 a month.

**ALEXANDER BLACK, LTD**  
**WIRELESS CONSULTANTS**  
 55, EBURY STREET, LONDON, S.W.1.  
 ESTABLISHED IN 1925. SLOANE 1655.  
 Trade Inquiries Invited.

**SERVICE**  
 SETS OF ALL TYPES.  
 Supplied, Serviced and Visited in any district, or may be sent for Full Test and Report, at 2/- per valve-holder; portables 1/6 per valve-holder.

**ACCUMULATOR CHARGING IS A PAYING PROPOSITION.**  
 Complete plant, incorporating Westinghouse Rectifiers, for A.C. Mains Supply, from £4-4-0  
 Send for Descriptive booklet.  
**MAINS' POWER RADIO, LTD.,**  
 Eastern Road - Romford.

**Cage Birds**  
 The weekly journal for all who keep Canaries, British Hybrids or Foreign Pet Birds.  
 EVERY FRIDAY 2d. W.W.98  
 Specimen copy of recent issue free on request from The Publisher (W.W.), Dorset House, Stamford St., London, S.E.1

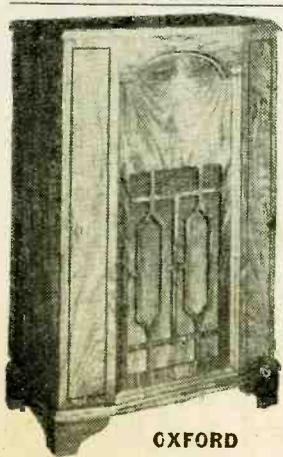

## OXFORD The De-Luxe Console Cabinet

An outstanding combination of craftsmanship and technical efficiency. Constructed of selected walnut veneer, beautifully polished. A handsome addition to any room. Price £3. 17s. 6d. See it at our showrooms, or write for free booklet.

**CARRINGTON MFG. CO., LTD.,**  
 24, Hatton Garden, London, E.C.1.  
 Holborn 8202.  
 Works: S. Croydon.



## THE MOST REMARKABLE VALUE EVER OFFERED

In High Quality Receivers.  
 12 Watts Undistorted Output.

### THE RAVOL RADIO RECEIVER

A Radio Receiver consisting of one accurately tuned H.F. stage employing 3 stage Band Pass and Transformer Tuning with Iron Cored Tuning Coils. Separation 9 K.C. with a very sharp cut off. Detector and 2 L.F. stages—last stage with 2PX25 in Push Pull worked on full output. Special Magna Speaker—High grade Cabinet (design prov. prot.) in Mahogany and Ebony.

**RADIO PRICE COMPLETE 26 GNS.**  
 The same as above with A.V.C. added and electrically driven turntable and Pickup.  
**GRAMOPHONE PRICE COMPLETE 36 GNS.**  
 Sole Manufacturer:  
**M. L. HILL, 5, Eldon Place, Newcastle-on-Tyne.**

When you renew your **rectifier**, change it for the last time . . .

Change now to **WESTINGHOUSE METAL RECTIFIERS** and obviate periodical renewal.

THE WESTINGHOUSE BRAKE & SAXBY SIGNAL CO., LTD.,  
82, YORK ROAD, KING'S CROSS, LONDON, N.1.

Your set here   
equals  
a fine  
**Radio  
-Gram**

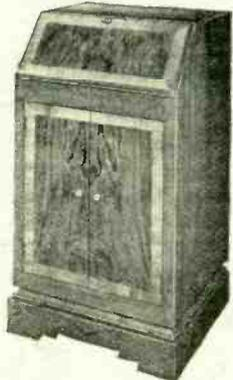

An Apollo Playing Desk will double the value and usefulness of your Wireless Set, as well as converting it into a handsome piece of furniture. You simply place the set on the Desk and connect Pickup leads.

**IN LIGHT, MEDIUM or DARK WALNUT TO MATCH VARIOUS WIRELESS SETS**

Size of top 18" x 11 1/2"

CASH PRICE

**8'GNS.**

or £6 deposit and 11 payments of 15/6.

As illustrated, with Collaro Induction Motor and Pickup, automatic current stop, volume control, record cupboard, etc. Also supplied fitted with GARRARD AUTOMATIC RECORD CHANGER and volume control complete for £15-5-0 cash, or 30/- deposit and 11 payments of 30/-.

**APOLLO PLAYING DESKS**

Ask your Radio Shop, or write to  
**BAXTER, STAVRIDI & CRAIES LTD.**

(formerly Apollo Gramophone Co., Ltd.)

4, Bunhill Row, London, E.C.1.

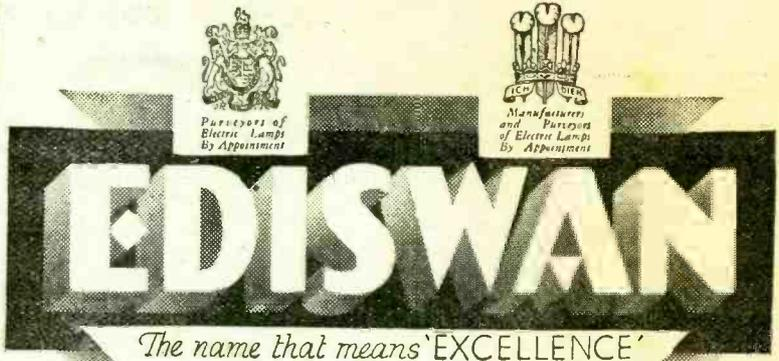

**EDISWAN**

The name that means 'EXCELLENCE'

**EXTRA LIFE**



Ediswan "Extra-life" accumulators are designed so that the positive and negative plates are in perfect electrical balance. This means quicker charging, longer discharging and extra life. And they have other special features, too—metal carriers, non-corrodible terminals, a host of minor refinements. Better, from every point of view, than ordinary cells, and no more expensive. Get your Ediswan to-day.

E.L.M.2. 20 a/h	- - 4/3	E.L.S.5. 40 a/h	- - 11/-	E.L.7. 60 a/h	- - 10/3
E.L.M.4. 45 a/h	- - 8/-	E.L.S.7. 60 a/h	- - 12/6	E.L.9. 80 a/h	- - 12/3
		E.L.S.9. 80 a/h	- - 15/6		

**EDISWAN**  
**EXTRA LIFE**  
**ACCUMULATORS**



THE EDISON SWAN ELECTRIC CO. LTD.  
PONDERS END, MIDDLESEX

**EDISWAN—the Better Service Batteries**

B275



## The Battery they depend on,

when the wireless may be the last hope, is the same in 9 out of 10 British ships! It is the Exide —the battery that will bring to you, clearly and consistently, the programmes of the Radio world.



# Exide

BATTERIES

#### H.T. ACCUMULATORS

Prices per 10-volt unit

WJ	2,500 milliamp. hrs.	-	5/-
WH	5,000 milliamp. hrs.	-	6/3
WT	10,000 milliamp. hrs.	-	12/-

*These prices do not apply in the Irish Free State*

*For the finest dry battery ask for Drydex*

Obtainable from Exide Service Stations and all reputable dealers. Exide Batteries, Exide Works, Clifton Junction, near Manchester  
 Branches: London, Manchester, Birmingham, Bristol, Glasgow, Dublin and Belfast